

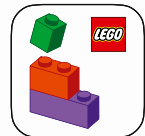

21367



Available in English
In deutscher Sprache verfügbar
Disponibles en français
Disponibile in italiano
Disponible en español
提供中文版本



LEGO® Builder





LEGO.com/sustainable-packaging



FR
DONNEZ
OU
RECYCLEZ



OU



OU



ASSOCIATION MAGASIN DÉCHÈTERIE

Adresses sur quefairedemesdechets.fr



BUILDER



LEGO® Builder



Apple and the Apple logo are trademarks of Apple Inc., registered in the U.S. and other countries and regions. App Store is a service mark of Apple Inc. Google Play and the Google Play logo are trademarks of Google LLC. Tencent and the Tencent logo are trademarks of Tencent Inc.

[LEGO.com/devicecheck](https://www.lego.com/devicecheck)

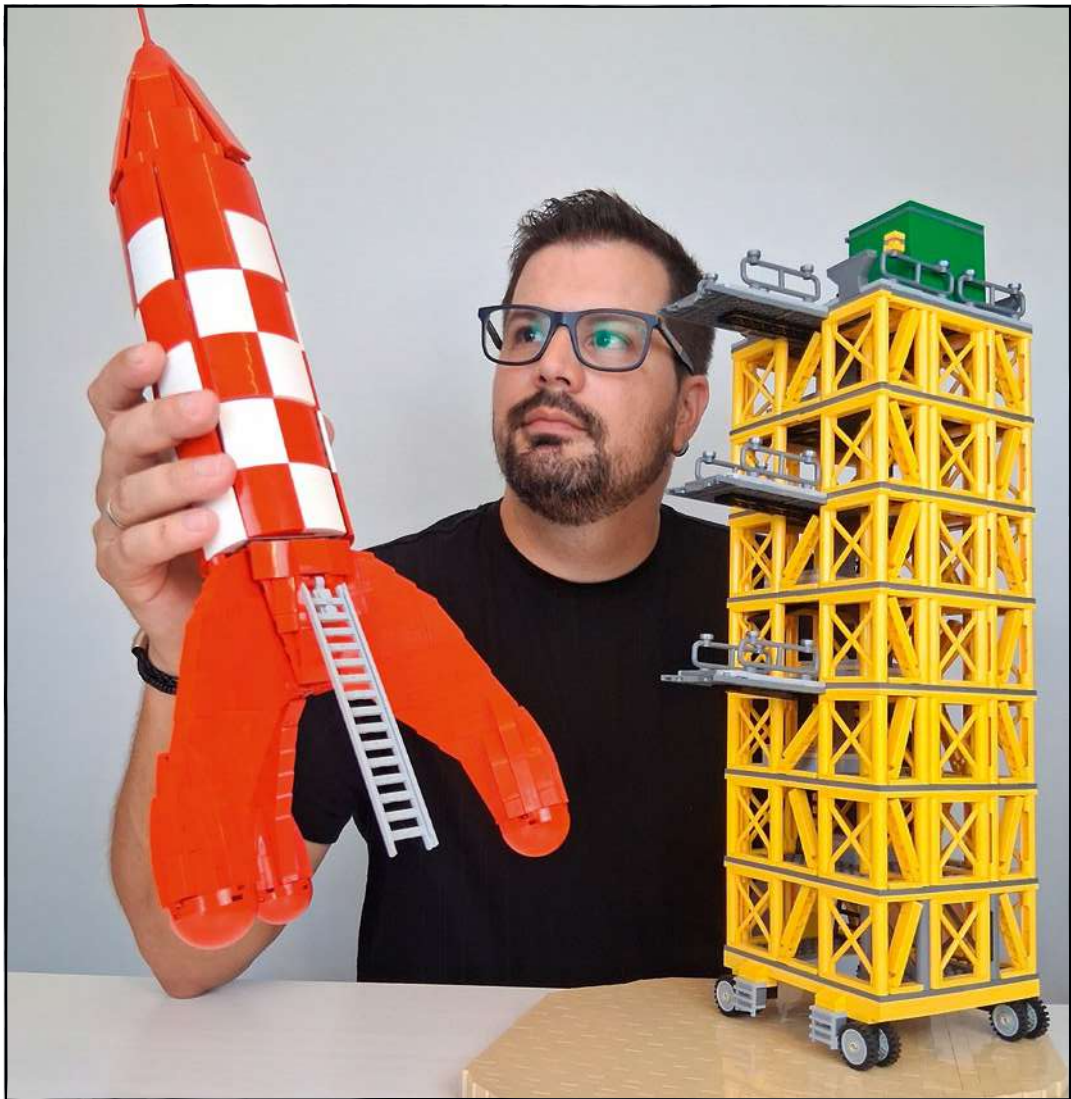

*LEGO® Ideas Fan Designer
Alexis Dos Santos with his
original model*

MEET THE FAN DESIGNER

How Alexis Dos Santos (LEGO® Ideas name Tkel86) from Portugal finds enough hours in the day for his job as a programmer and web designer is a mystery to us. With an extensive portfolio of intricate MOCs (My Own Creations), this Fan Designer keeps busy!

"In my free time, I love doing anything that mixes creativity with ingenuity – LEGO building, electronic projects, woodworking, drawing, graphic design, 3D models and sculpting. I love reusing materials for new purposes, like disassembling a LEGO set to create another. I always remember playing with LEGO bricks – when I was a child, I inherited a box full of pieces from a cousin, and from then on, I grew my collection until I was a teenager. I had what you call a 'dark age' away from the bricks from when I was 16 to 26. Then I rediscovered my passion when, by chance, I visited a LEGO fan exhibition created by a community. I ended up joining them, and this hobby grew exponentially. This project took about six months. I've always

admired Tintin, and a co-worker inspired me to recreate this model in LEGO bricks. I used some Technic parts to obtain the fittings for the legs and the top cone. I like that the model uses round and conical elements made from multiple pieces, as it is always a challenge to be able to reduce visible gaps with relatively complex fittings. Some of these elements in red were difficult to find! After I shared it on the LEGO Ideas website, my plan was to keep refining it, but little by little, while I was busy working on other projects, it reached 10,000 supporters. I love it when models combine mechanised movements and beautiful aesthetics. I hope fans will love the final model's wow factor."



Alexis' model, and the image from the book that sparked his idea



© Hergé/Tintinimaginatio 2026

AN EXPLORER ON THE MOON!

The red-and-white chequered rocket from *Destination Moon* (1953) and *Explorers on the Moon* (1954) remains one of the most recognisable symbols from *The Adventures of Tintin*. In the story, Tintin, Captain Haddock, Snowy and Professor Calculus embark on a daring journey to explore the dark side of the Moon, launching a groundbreaking rocket from the fictional country of Syldavia. When first published, the adventure transported readers into a future where human space travel felt within reach, at a time when an actual lunar landing was still only a dream. The rocket quickly became a signature image of technological progress and innovation, as Tintin and his friends captured the imagination of millions with a blend of adventure, suspense and modern science.

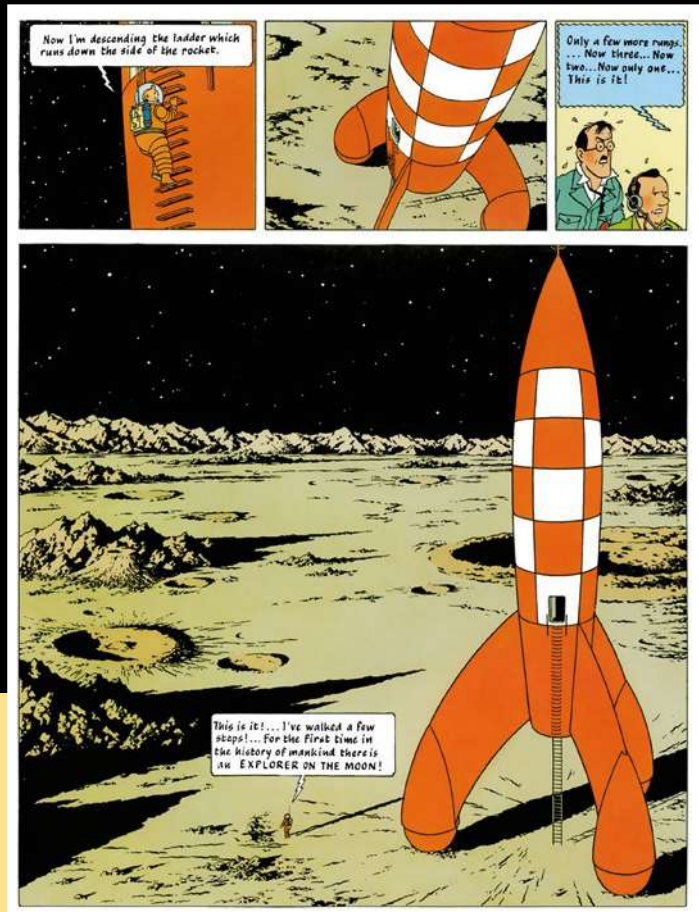

© Hergé/Tintinimaginatio 2026



ART MEETS SCIENCE

The story seamlessly wove the characters' familiar banter, wit and humour into a suspenseful tale of espionage and scientific discovery. Because the rocket design, the Sprodj Atomic Research Centre and the journey's technical details were all based on real research available at the time, the story felt both novel and convincing, and the richly detailed scenes brought advanced science to a wider audience. Tintin's legacy is now preserved in places like the Musée Hergé, and the pioneering spirit of his rocket continues to inspire dreamers and explorers alike.

© Hergé/Tintinimagination 2026



Many details were based on real science.



© Danny Gys - Atelier Christian de Portzamparc Hergé-Tintinimagination 2026

Hergé compiled extensive research materials and documents. Some are of unclear origin, like these black/white photos, that are classified under a separate 'Hergé Documentation' category.

THE LEGO® IDEAS TEAM

The fan model was really well done - it was also enormous! So, we agreed to remove the tower and focus on the rocket itself, take Alexis' model from Earth to space, and feature the characters in their iconic space suits, including, of course, a LEGO® Snowy figure! Hergé famously paid vigilant attention to detail and accuracy, and we wanted to do his work justice. The rocket is a 6-sided shape with a subtle curve from top to bottom. We explored countless different building techniques and angles to achieve this shape. The squares of the chequered pattern on the rocket surface

are trapezoidal, and to stay true to the design, the smooth surface and authentic pattern were an exciting challenge. The fins were another technical part of the model. The solution for this was to use a reflected triangle for each of the fins to create the correct angle and lock them in to add strength to the model. For the rocket's top cone, we created a new cone element that's similar to the rocket's feet for consistency.



© Hergé / Tintinimaginatio 2026





We included a control room at the top of the rocket to show an iconic scene after take-off, when the characters see Earth from space for the first time. We made it as accurate as possible, with decorations, details and stickers, and we even managed to add the hatch for the door into the next level in the rocket.

'Translating' the characters into minifigure form was such a fun process. They have so much personality and comic history, so we narrowed it down to expressions that reflect this storyline. The spacesuits are inspired by *Explorers on the Moon*, and Thomson and Thompson have their green hair as a nod to a hilarious scene in the comic book!

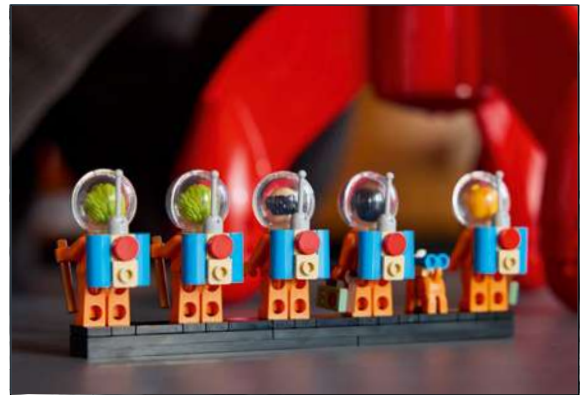

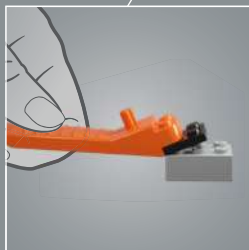
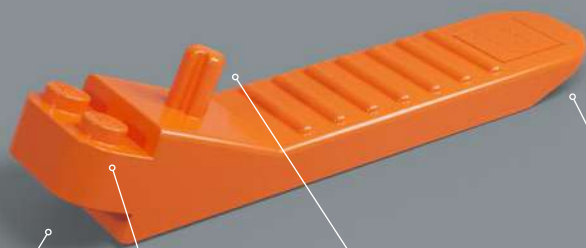

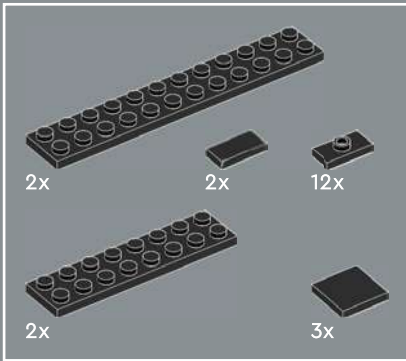
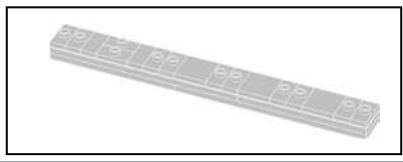

1

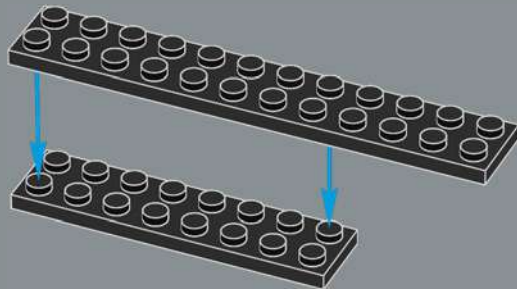

2

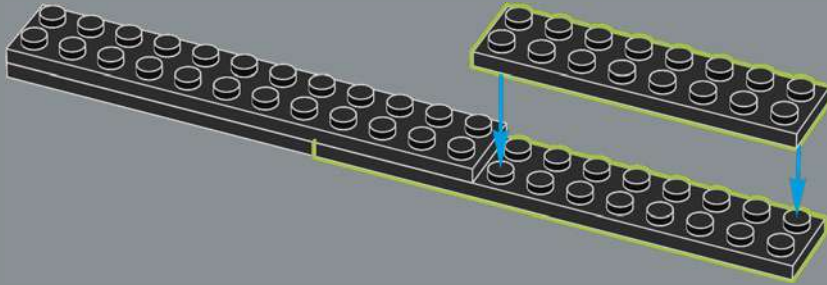

3

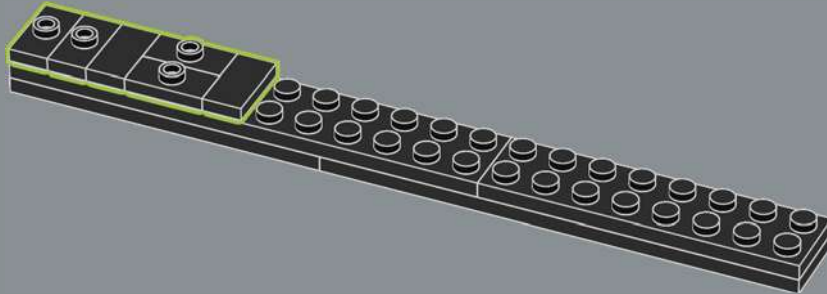

4

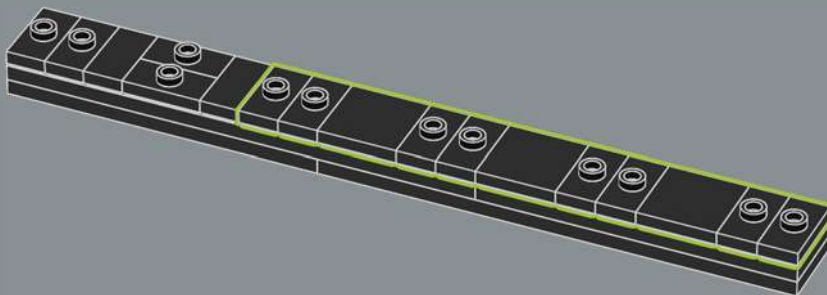

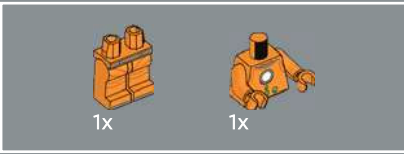

1

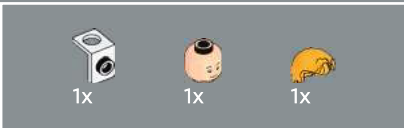
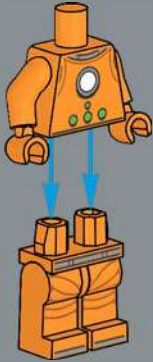

2

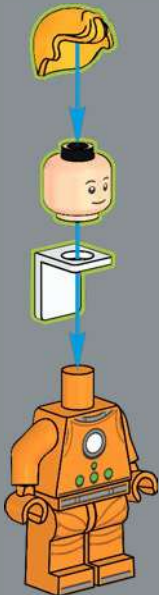

3

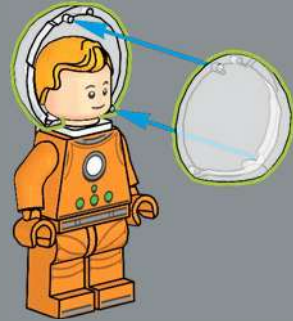

4

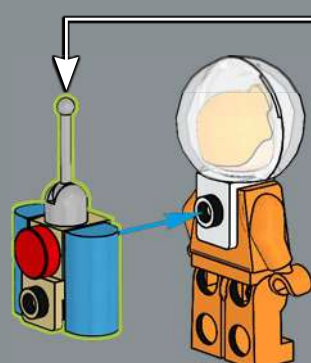
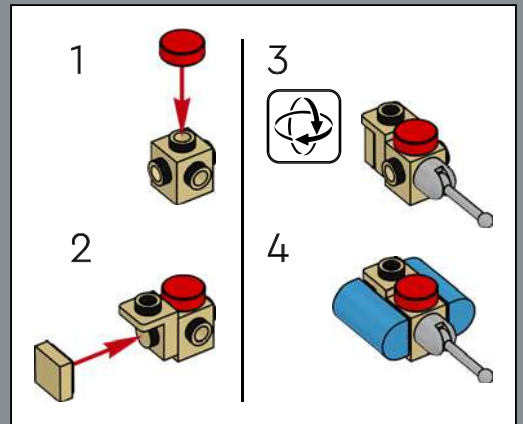



5

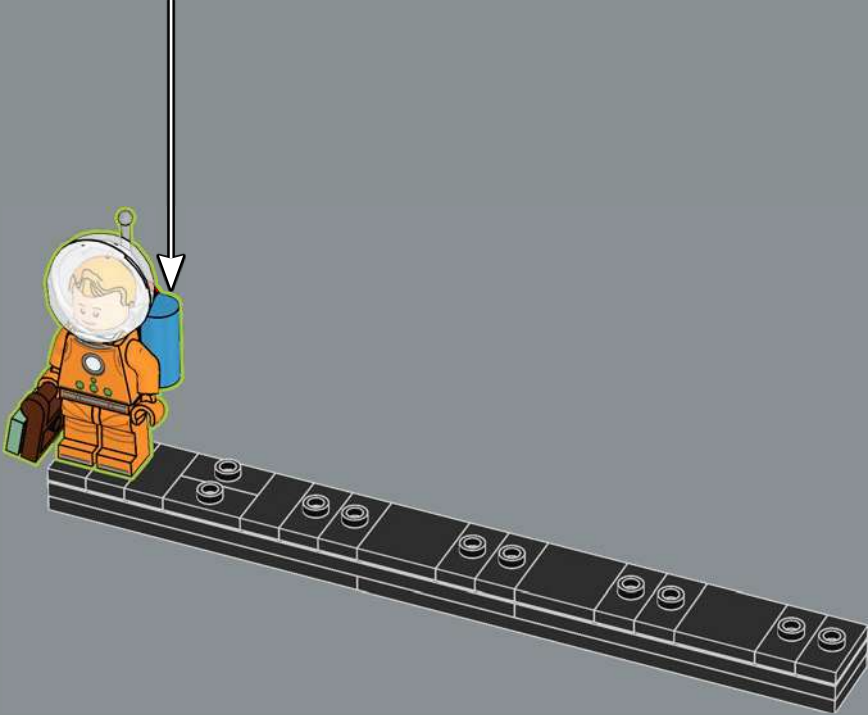
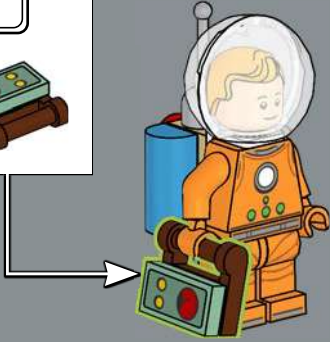
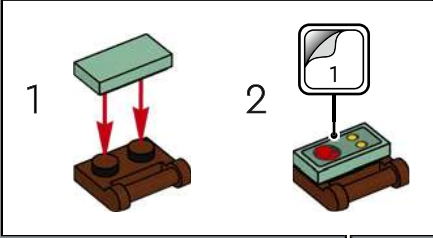

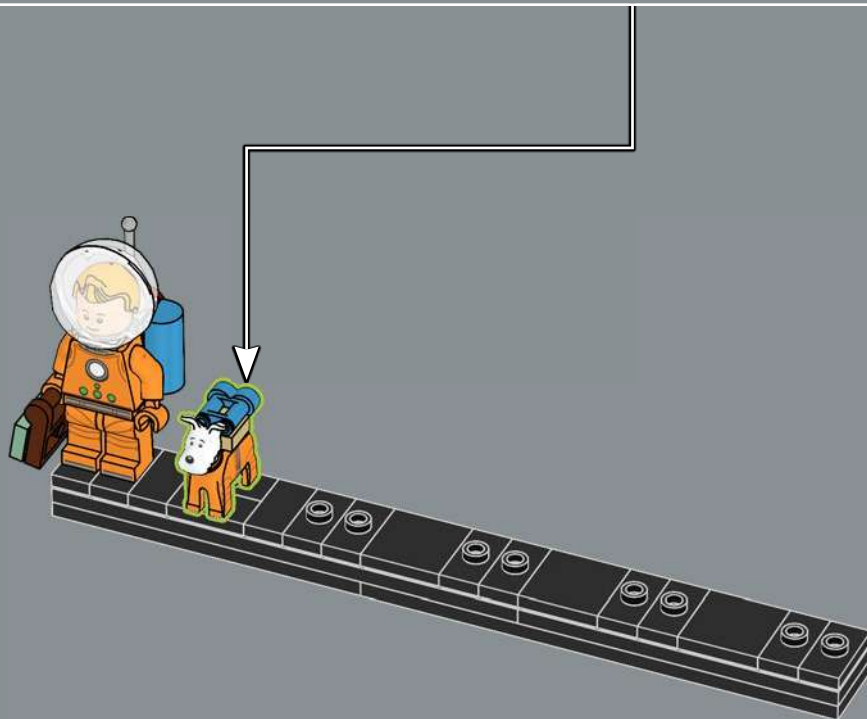

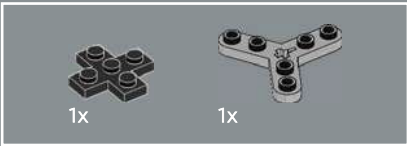
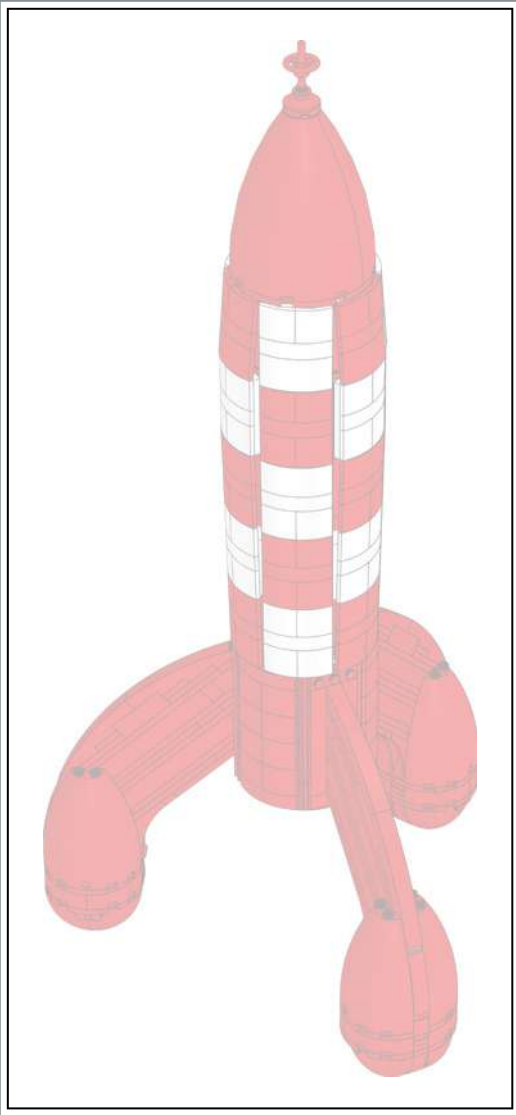

1

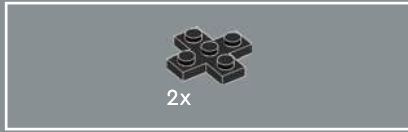

2

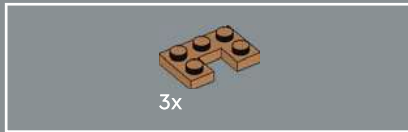
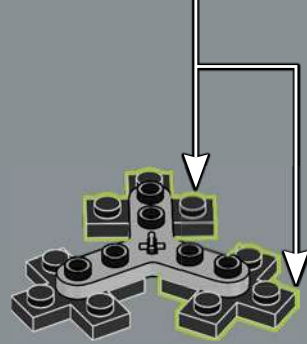

3

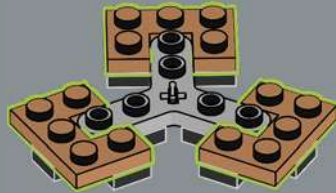

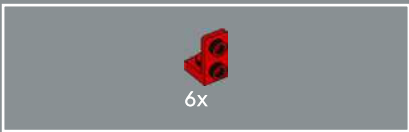

4

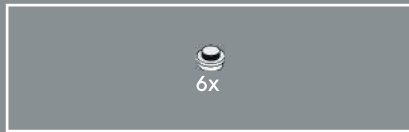

6

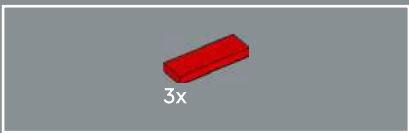

5

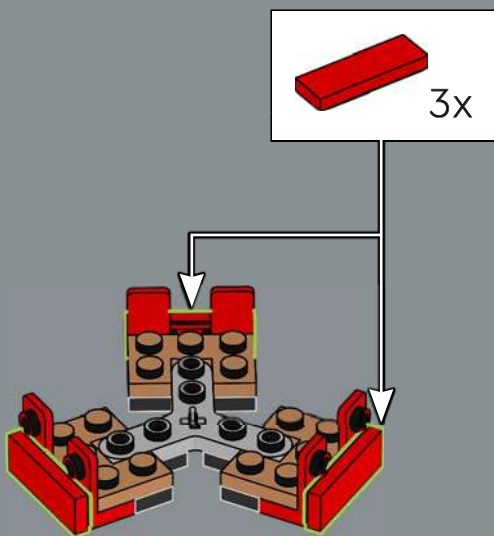

7

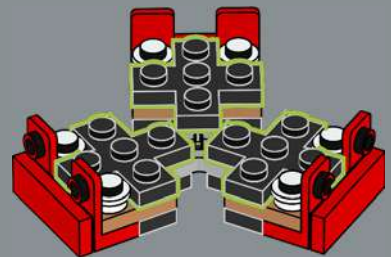

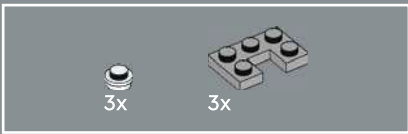

8



9

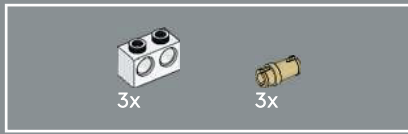

10

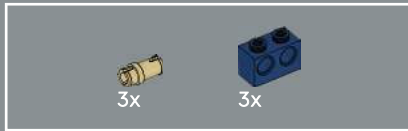
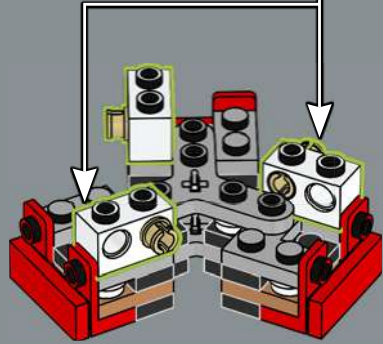
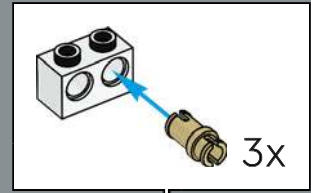

11

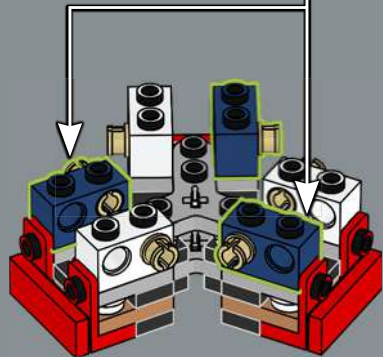
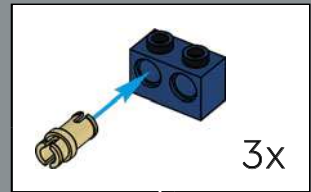



12

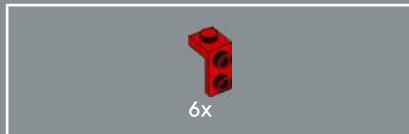
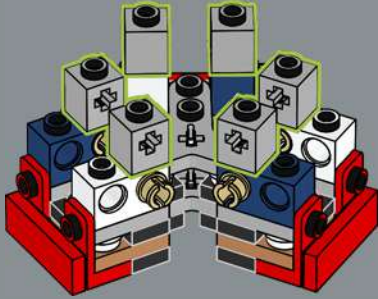

14

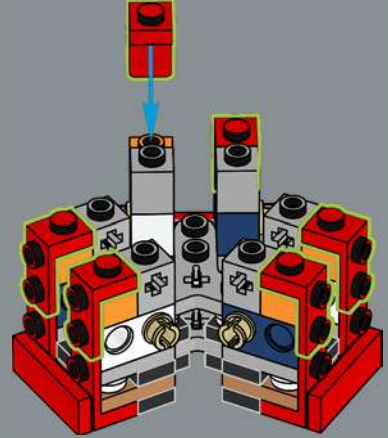

13

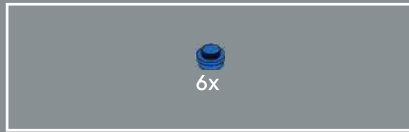
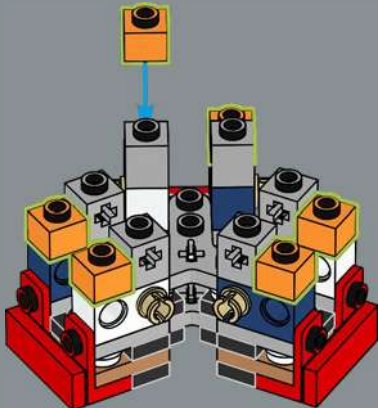

15

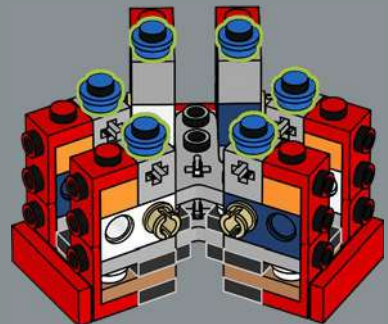

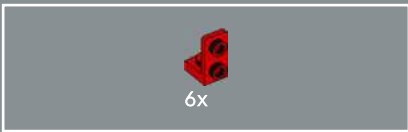

16

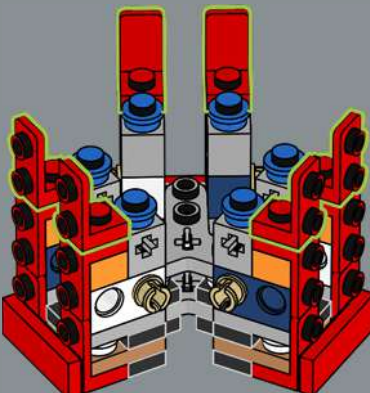

17

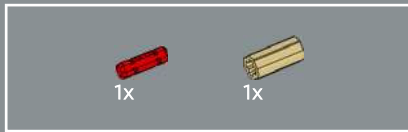
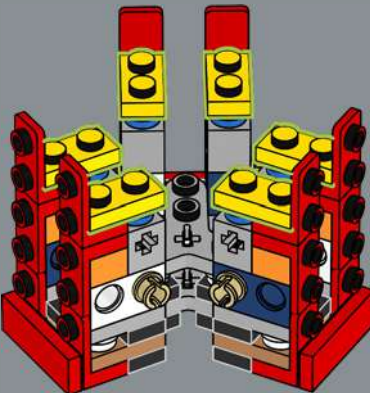

18

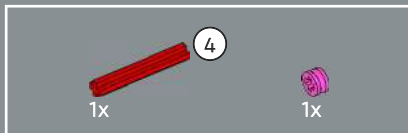
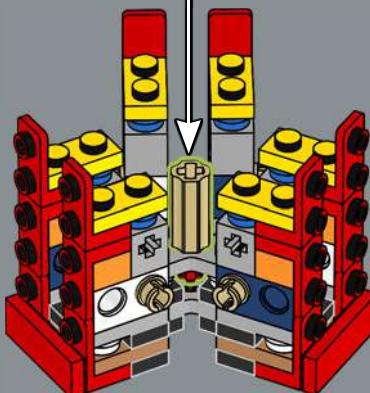
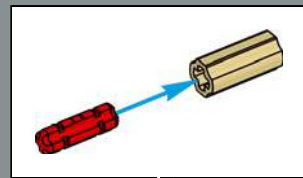

19

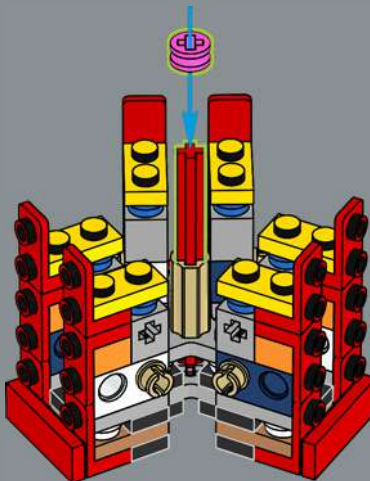

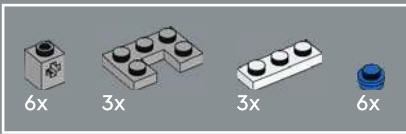

20

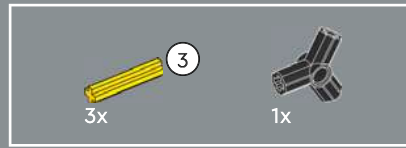
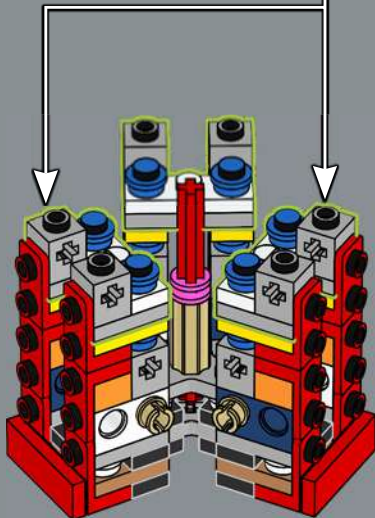
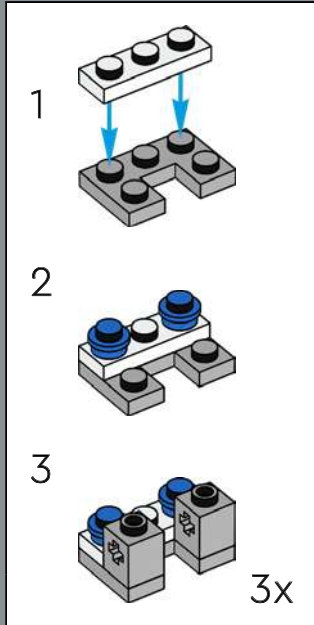

21

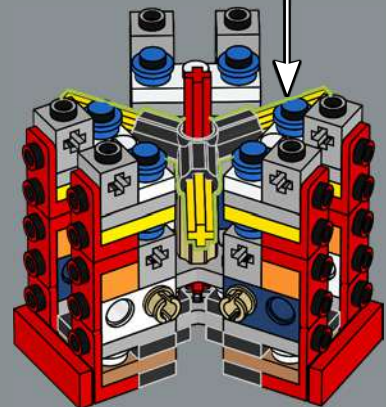
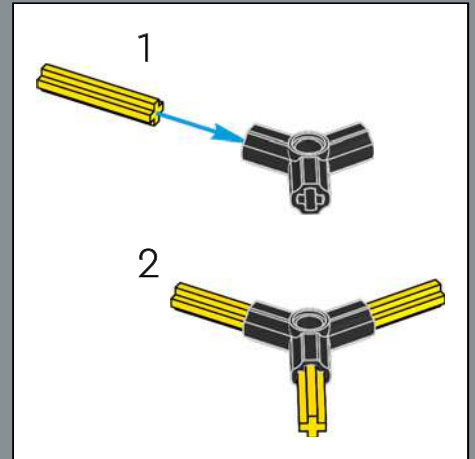



22

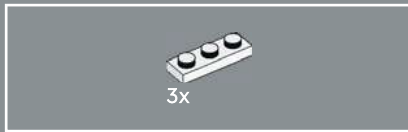
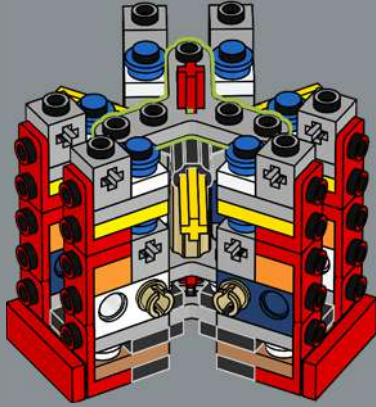

23

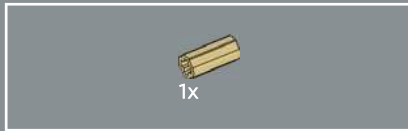
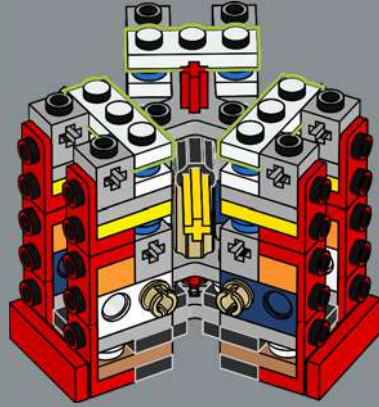

24

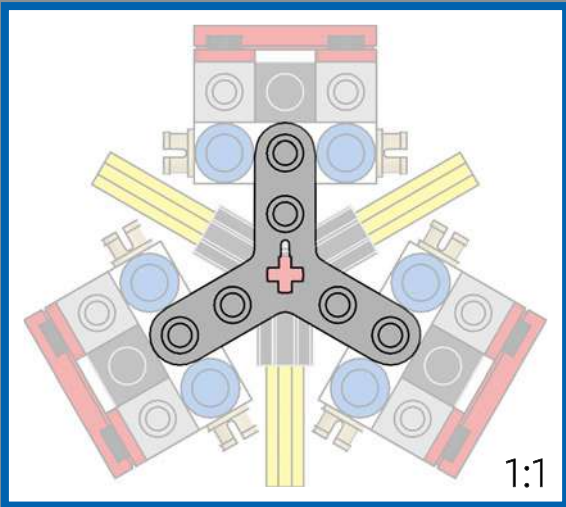
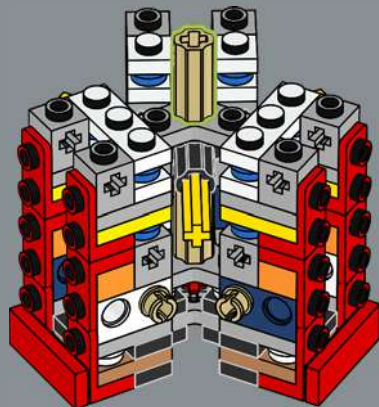

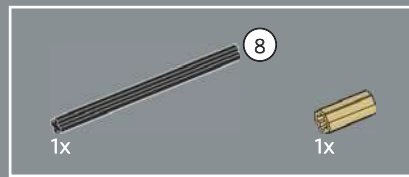

25

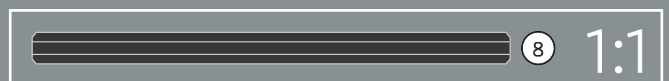
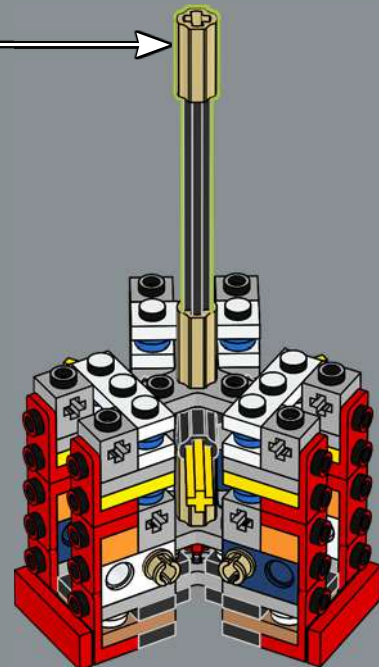
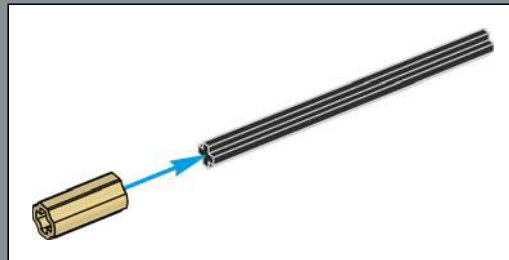

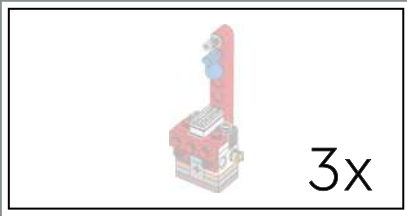

26

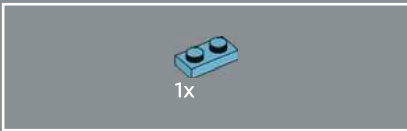
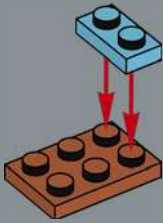

27

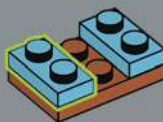

28

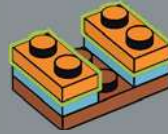

29

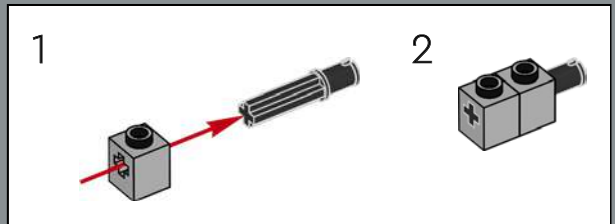

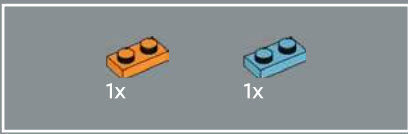

30

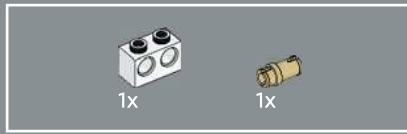

32

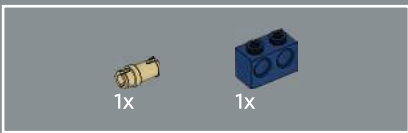
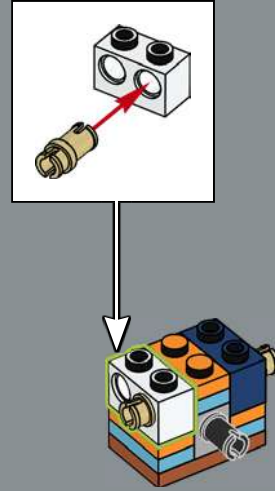

31

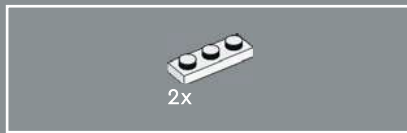
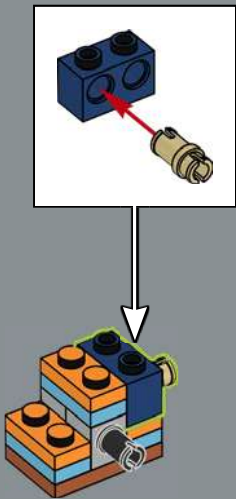

33

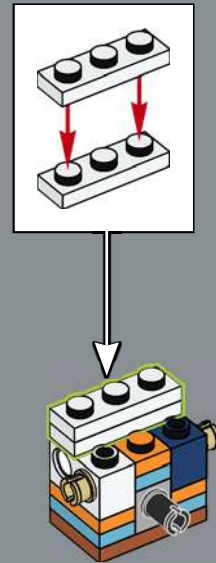

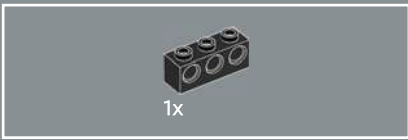

34



35

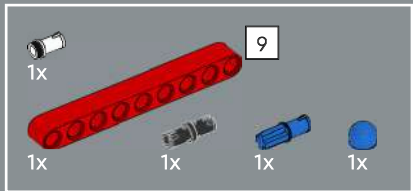
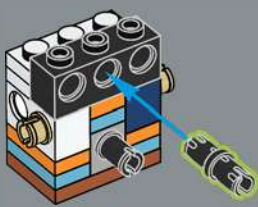

36

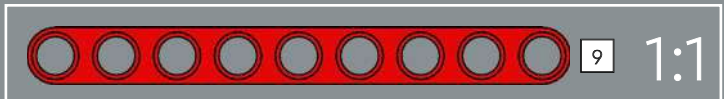
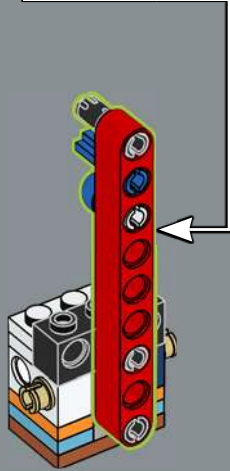
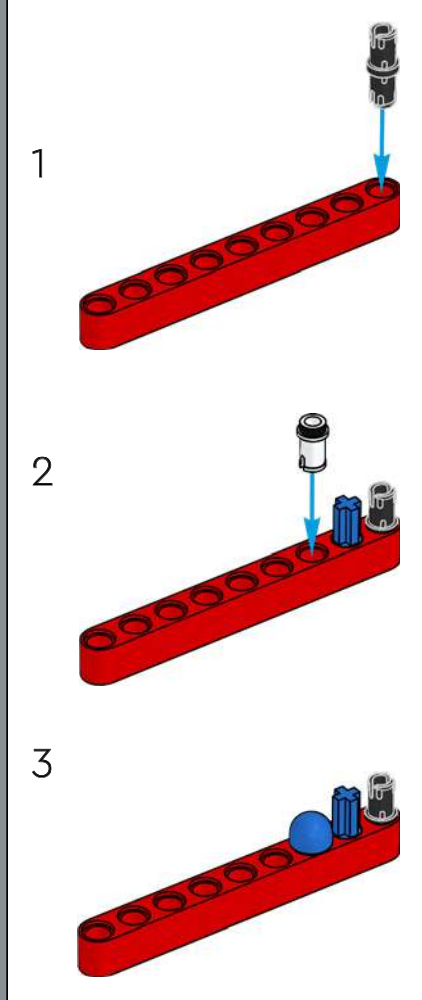

9 1:1





37

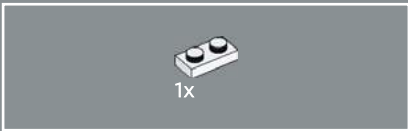
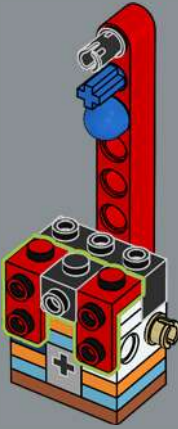

38

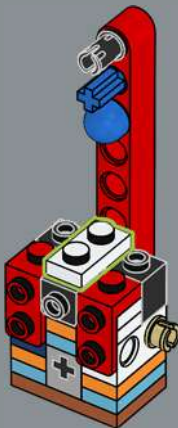

39

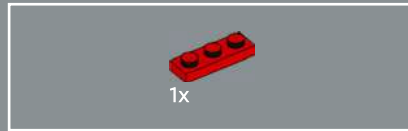
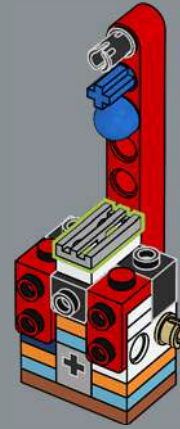

40

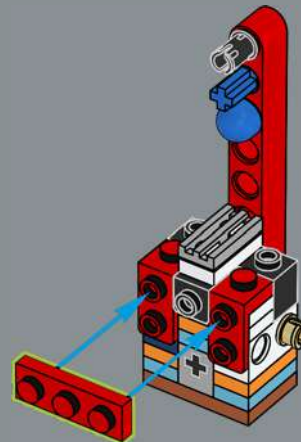

3x

41

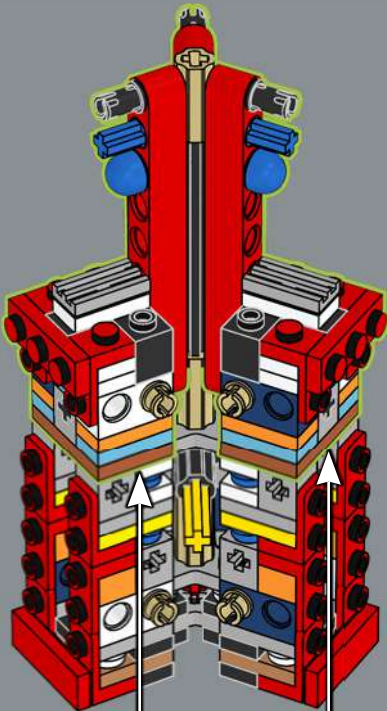

42

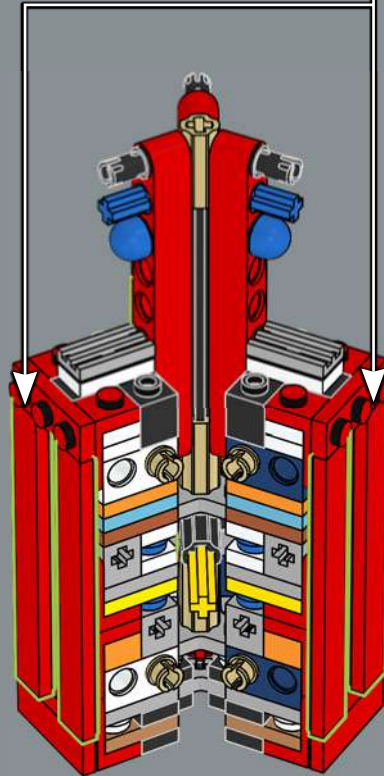
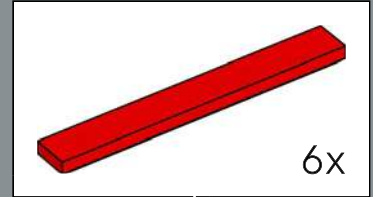
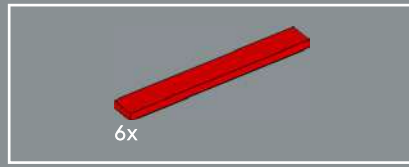

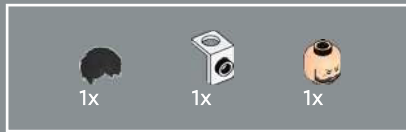

2

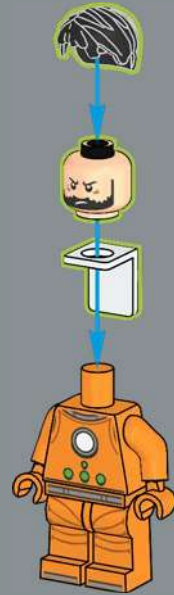

3

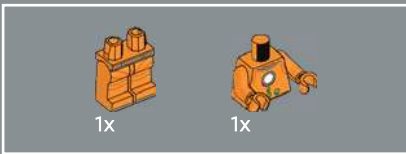
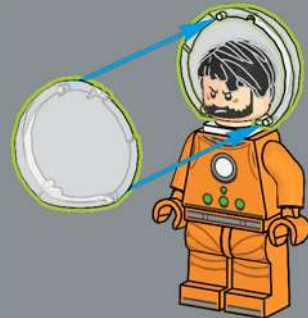

1

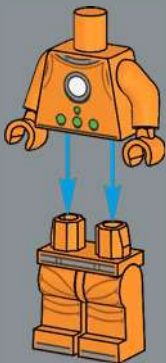



4

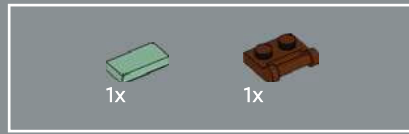
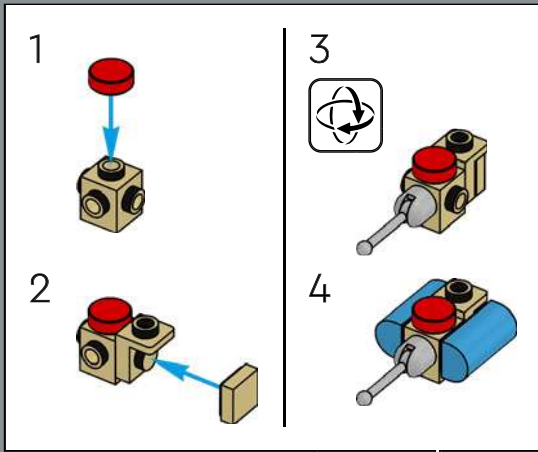

5

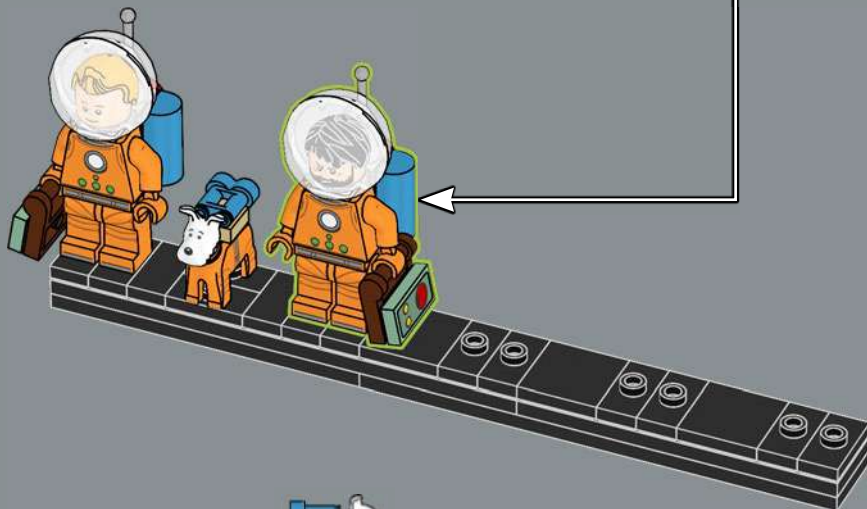
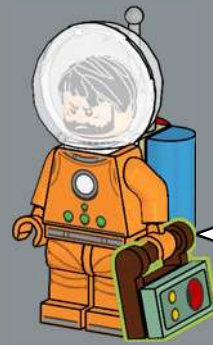
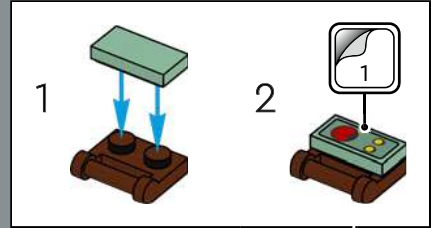

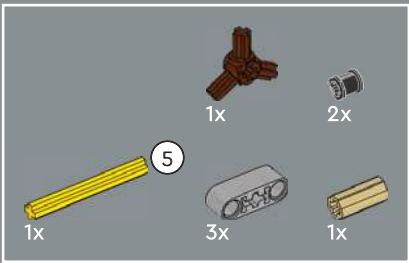

43

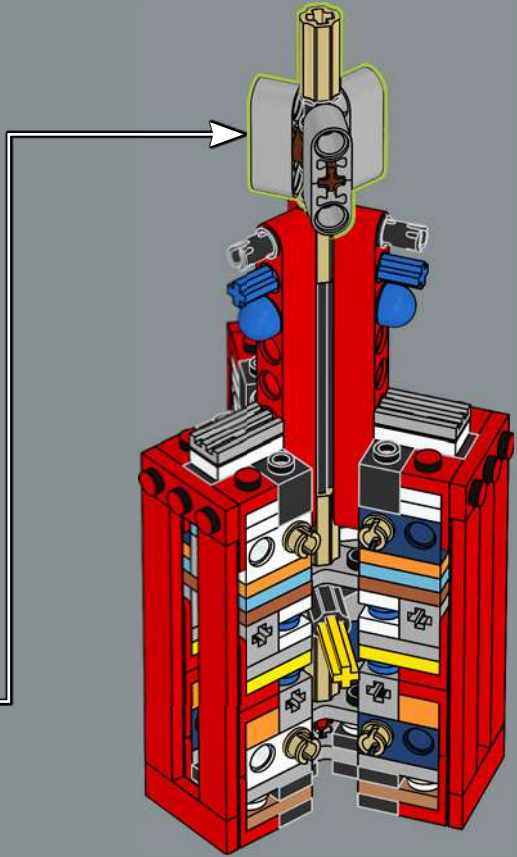
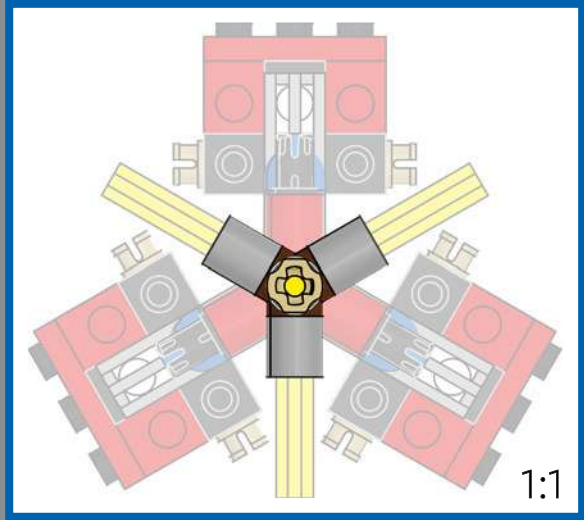
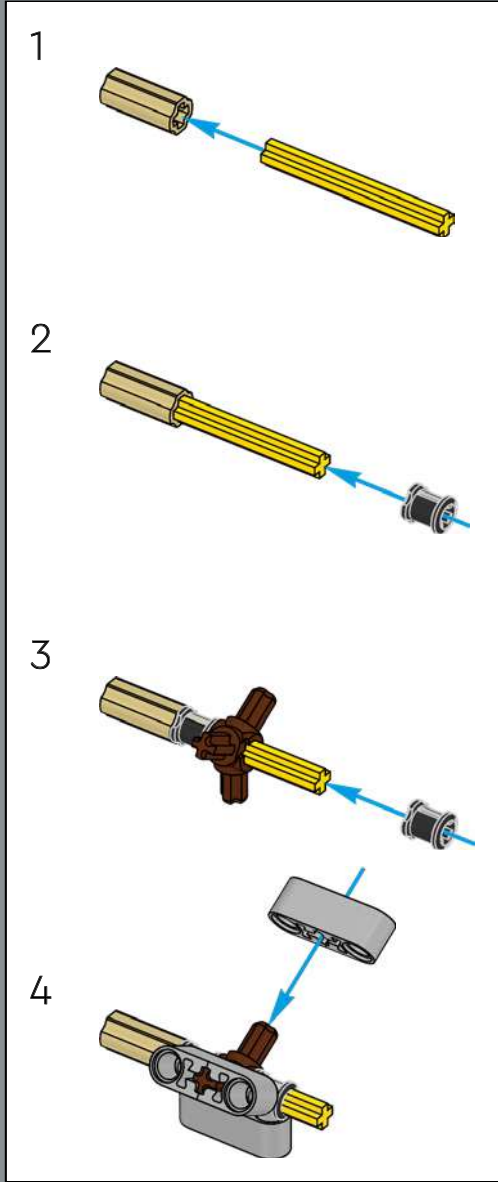

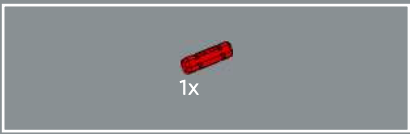

44

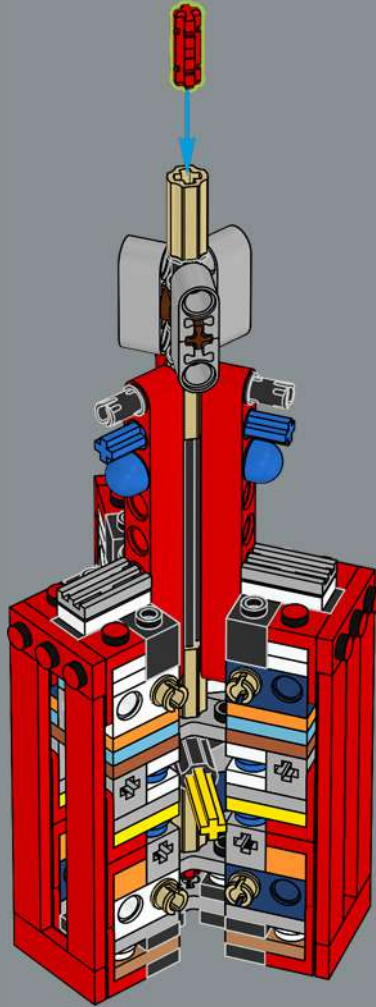



45

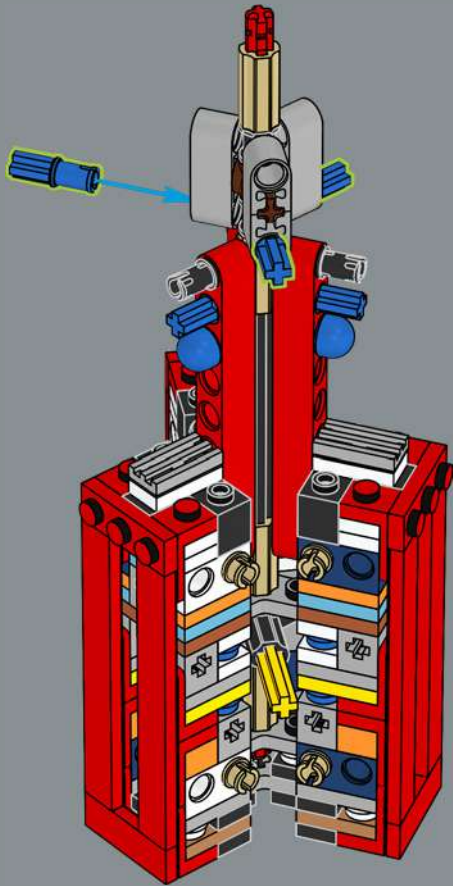

46

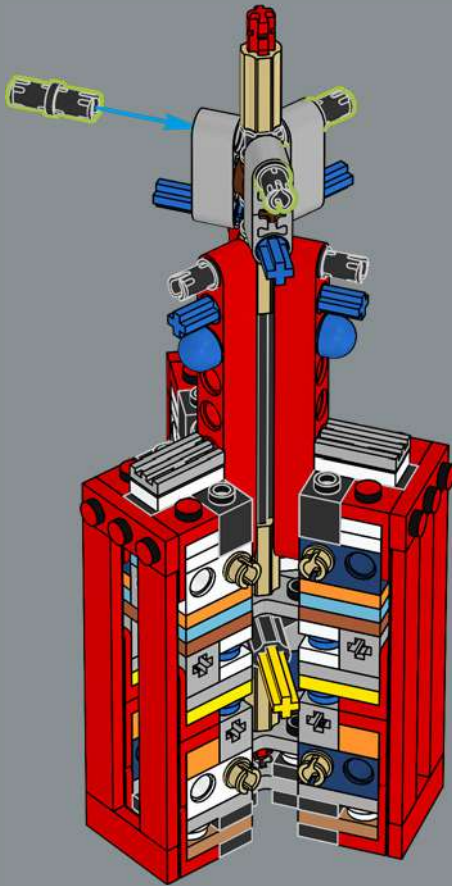

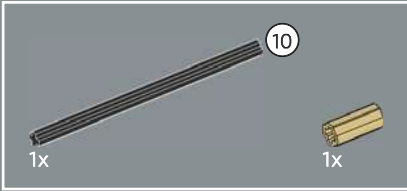
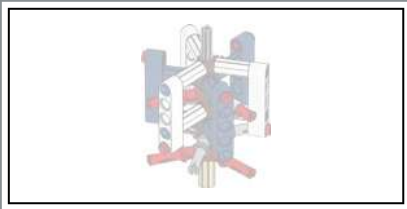

47

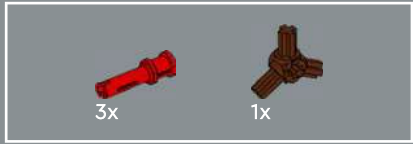
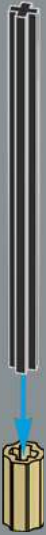

48

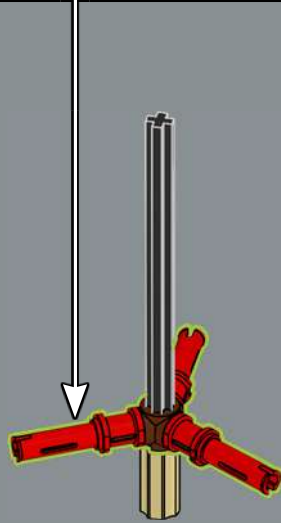
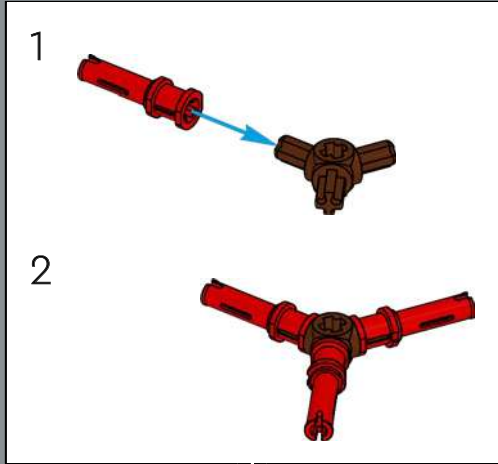



49

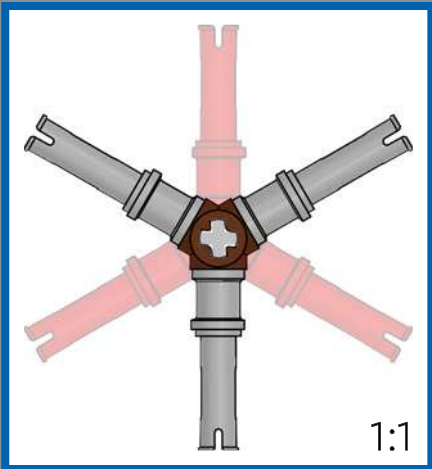
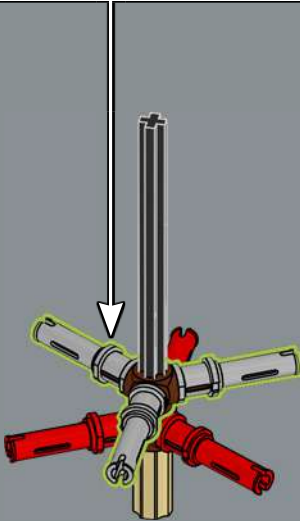
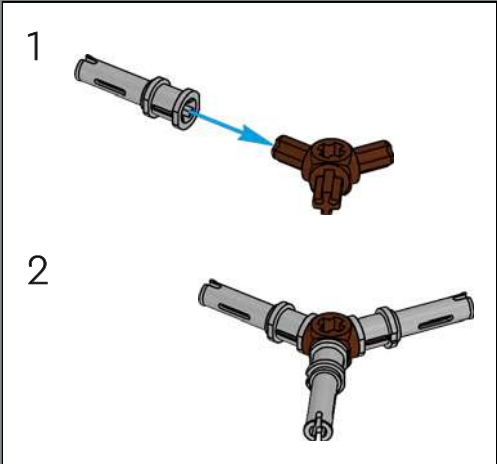

50

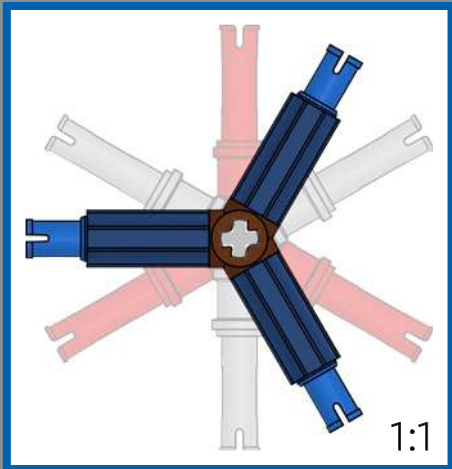
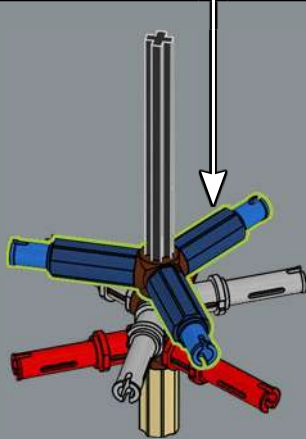
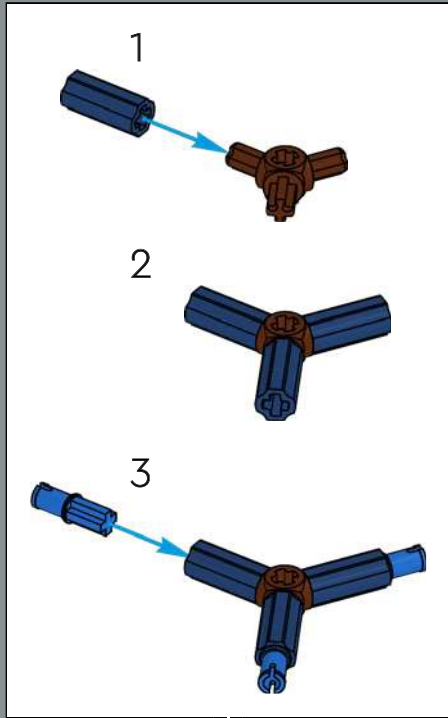

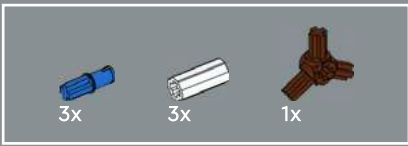

51

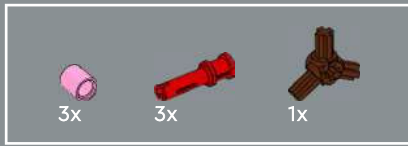
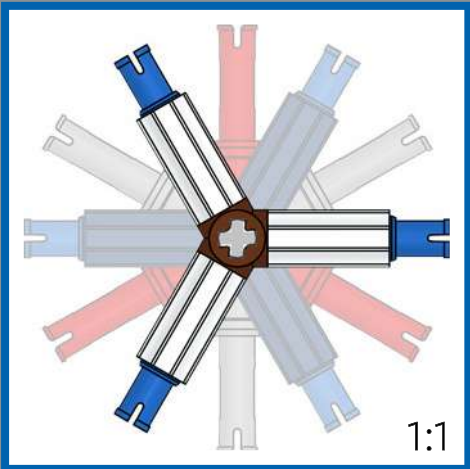
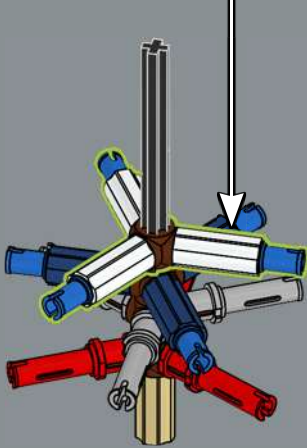
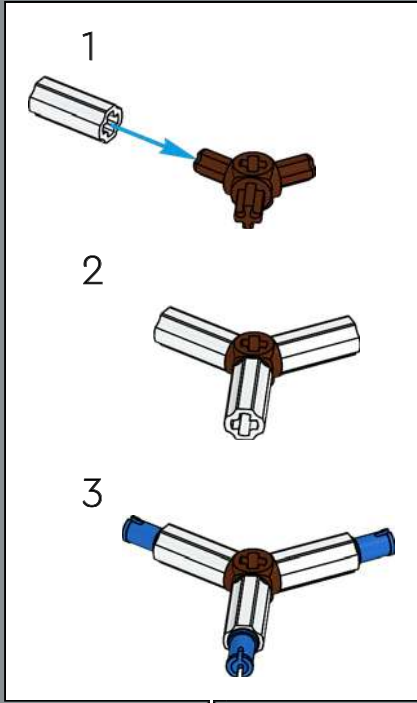

52

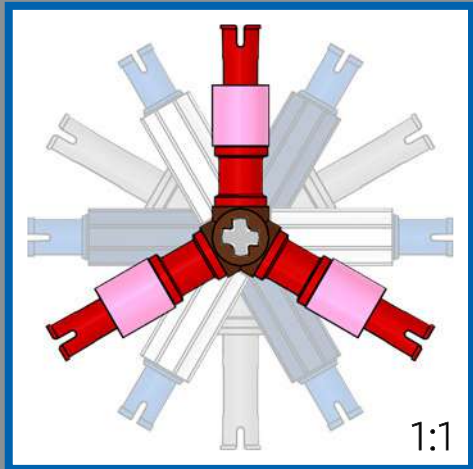
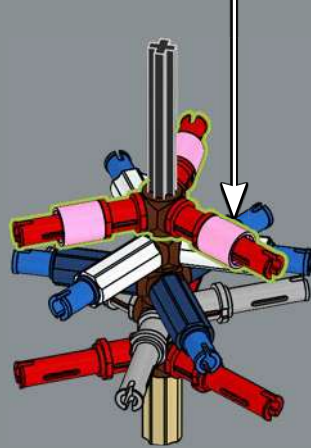
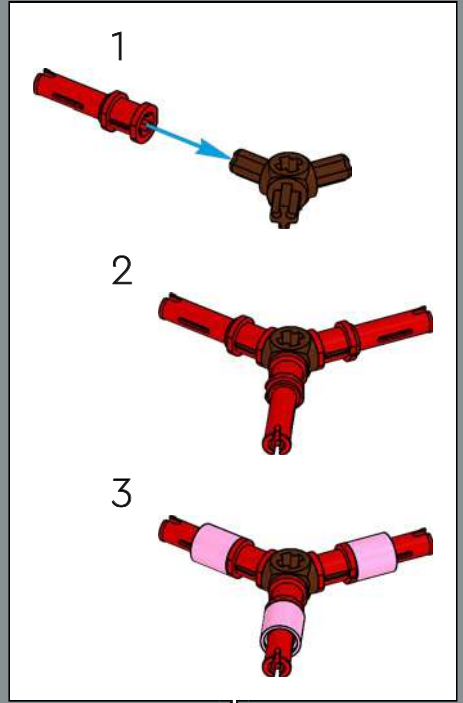



53

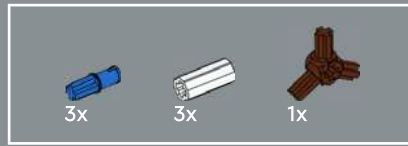
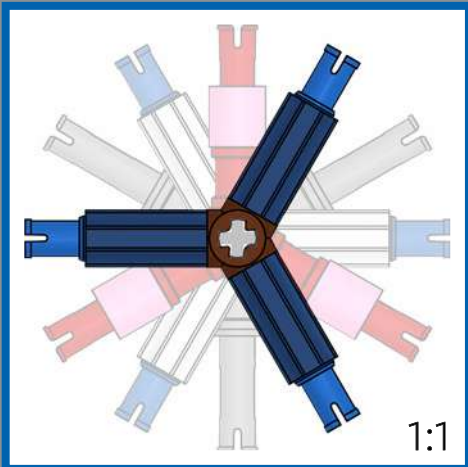
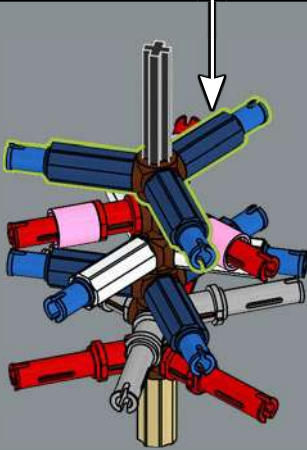
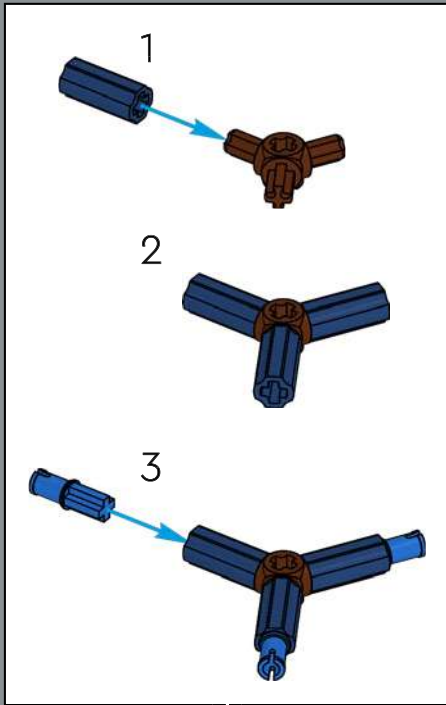

54

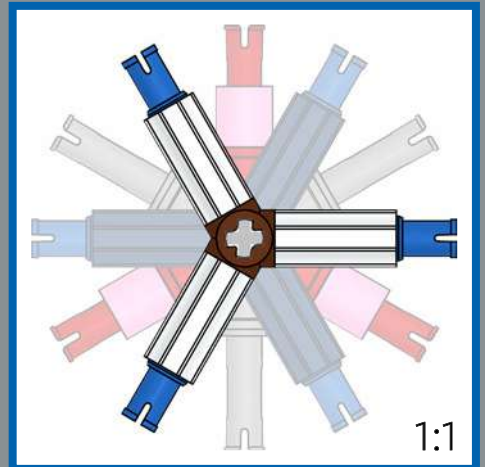
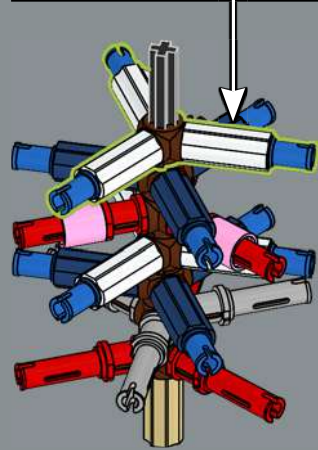
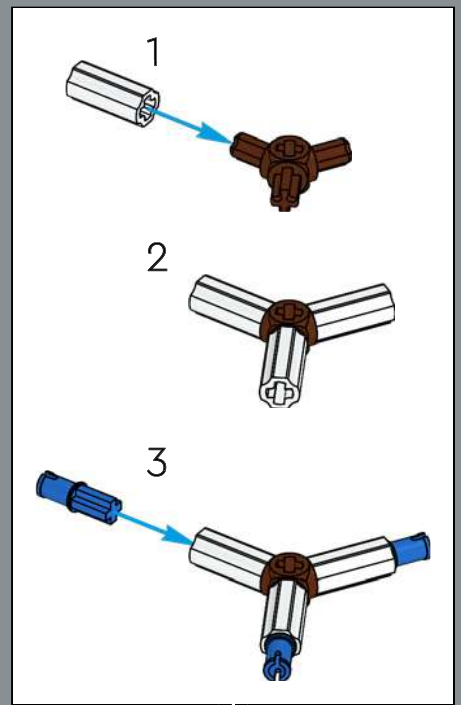

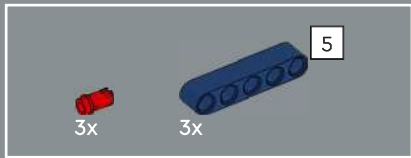

55

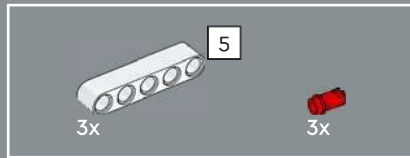
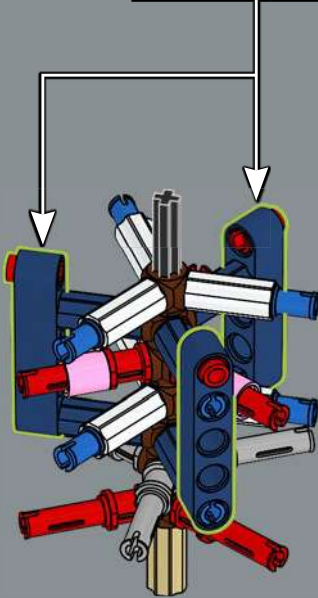
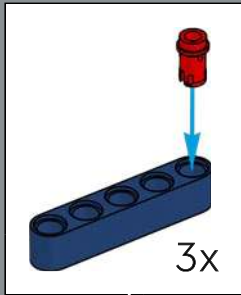

56

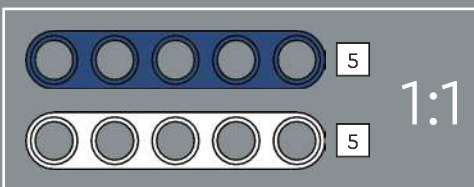
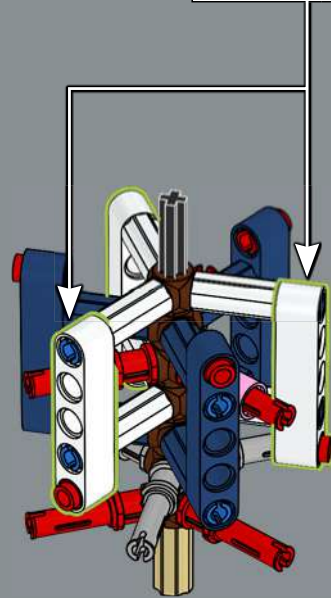
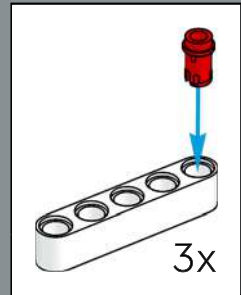

57

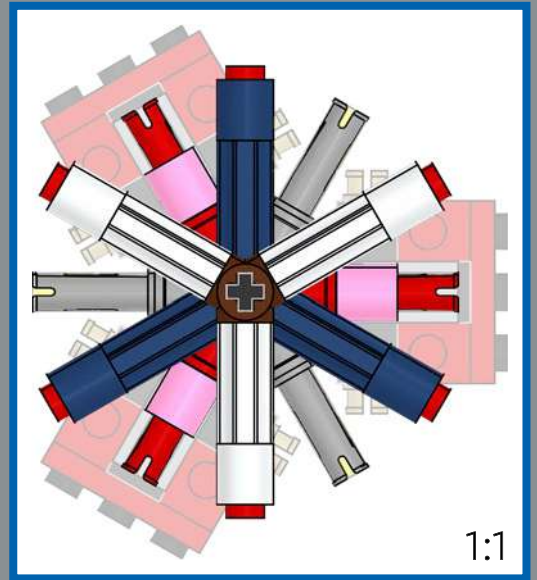
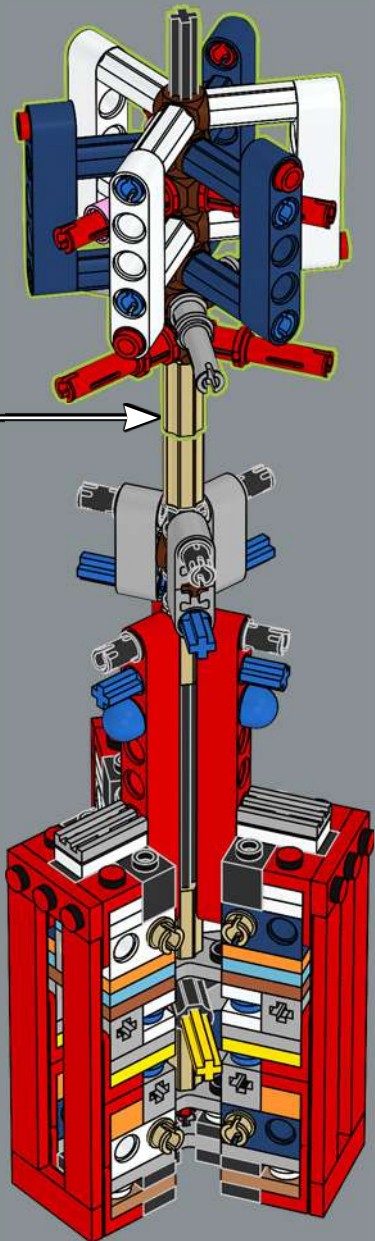

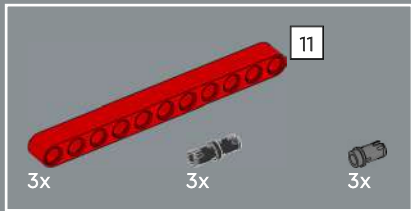

58

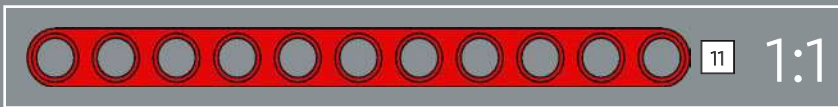
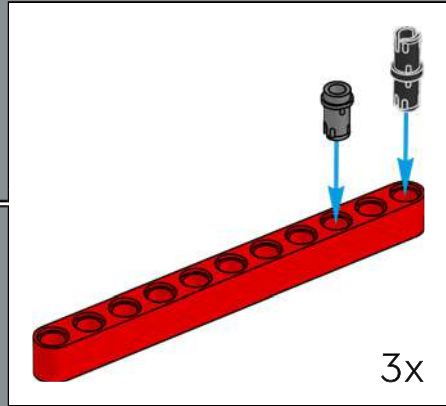
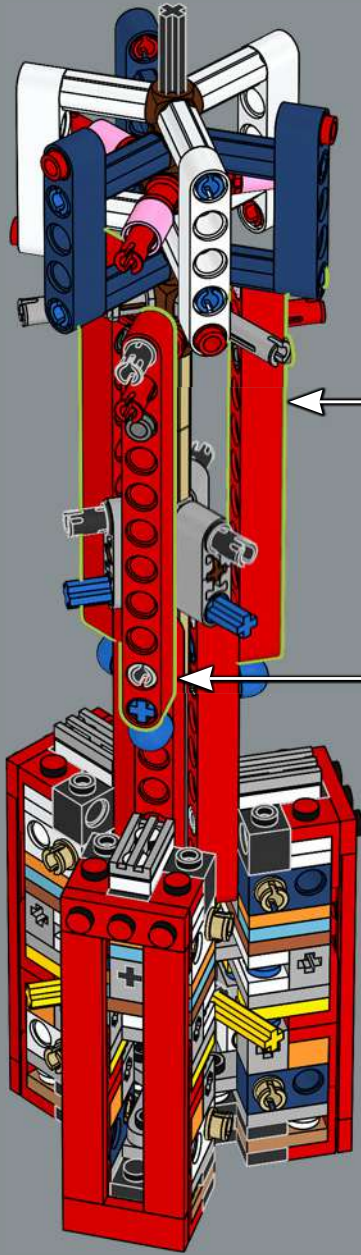

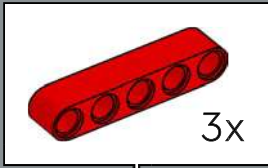
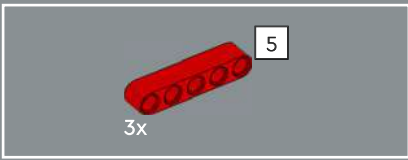

59

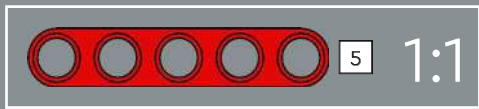
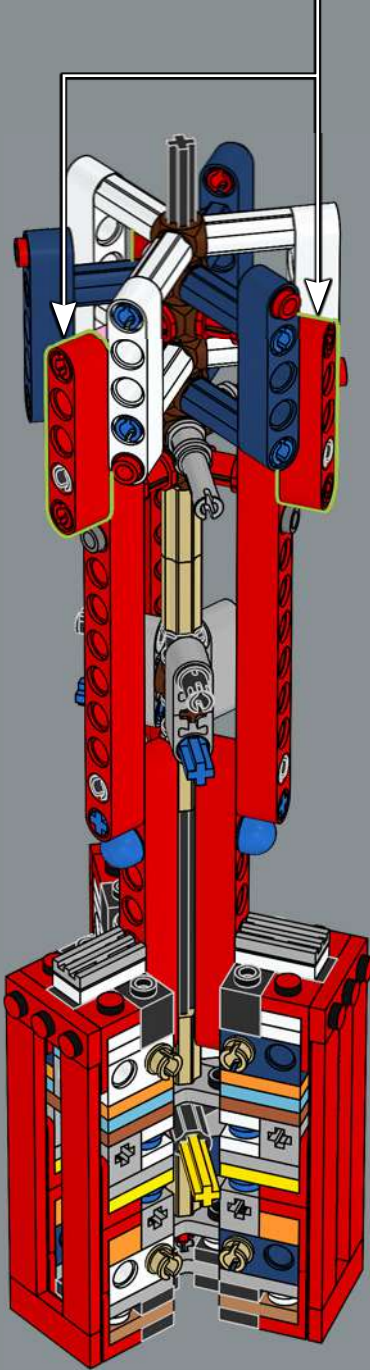

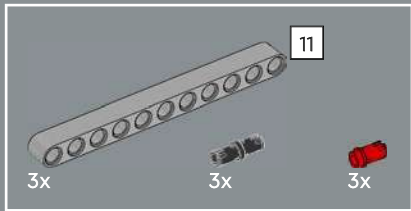

60

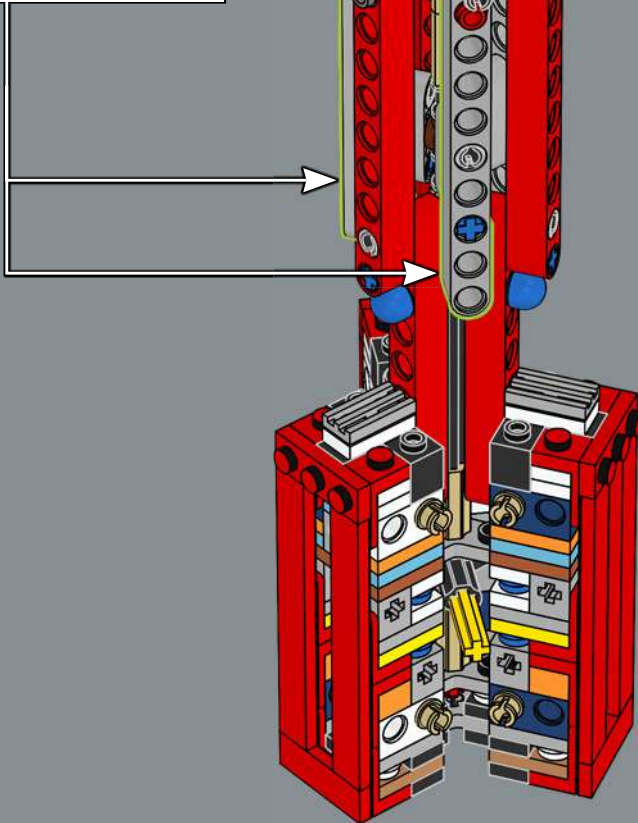
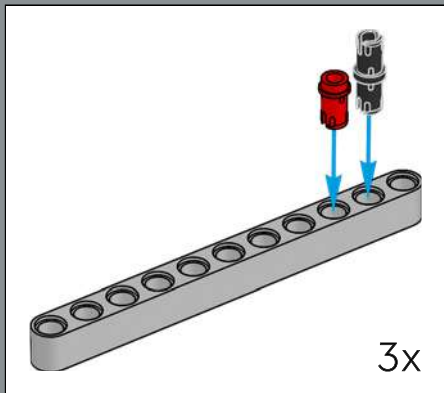



61

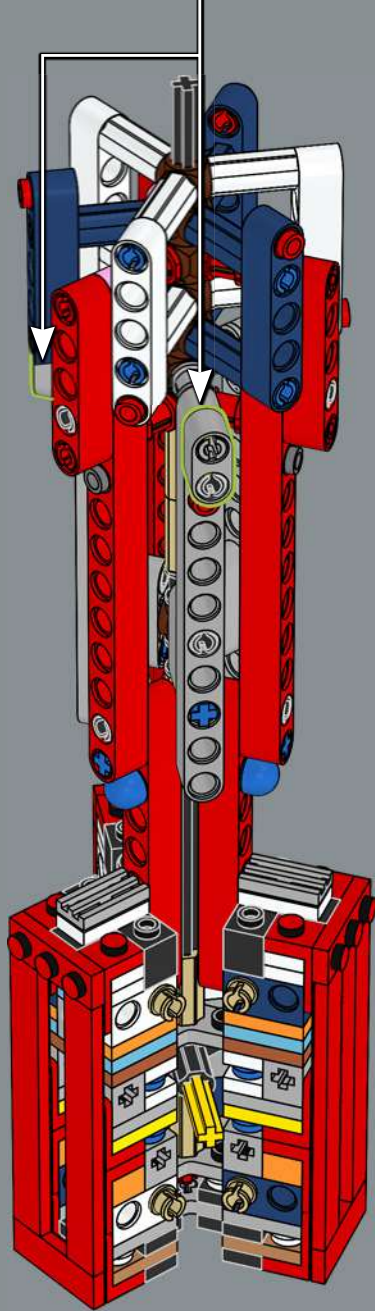

62

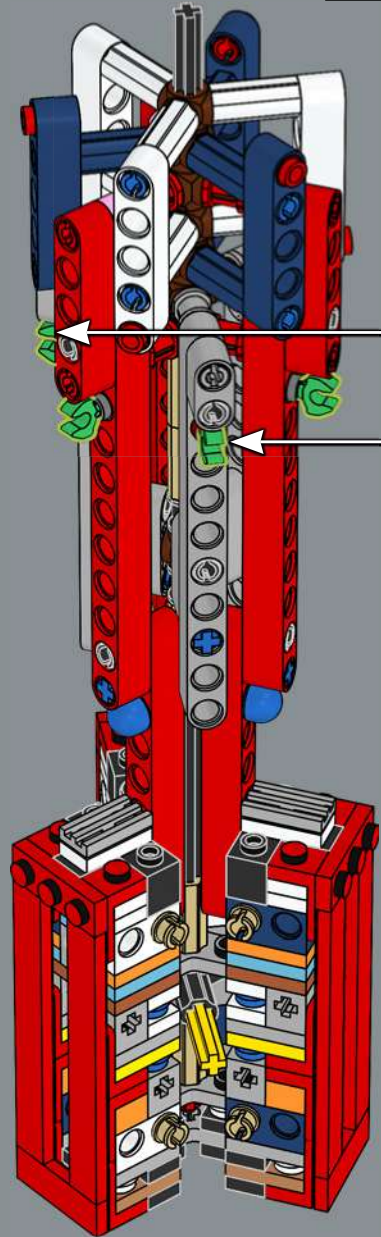



63

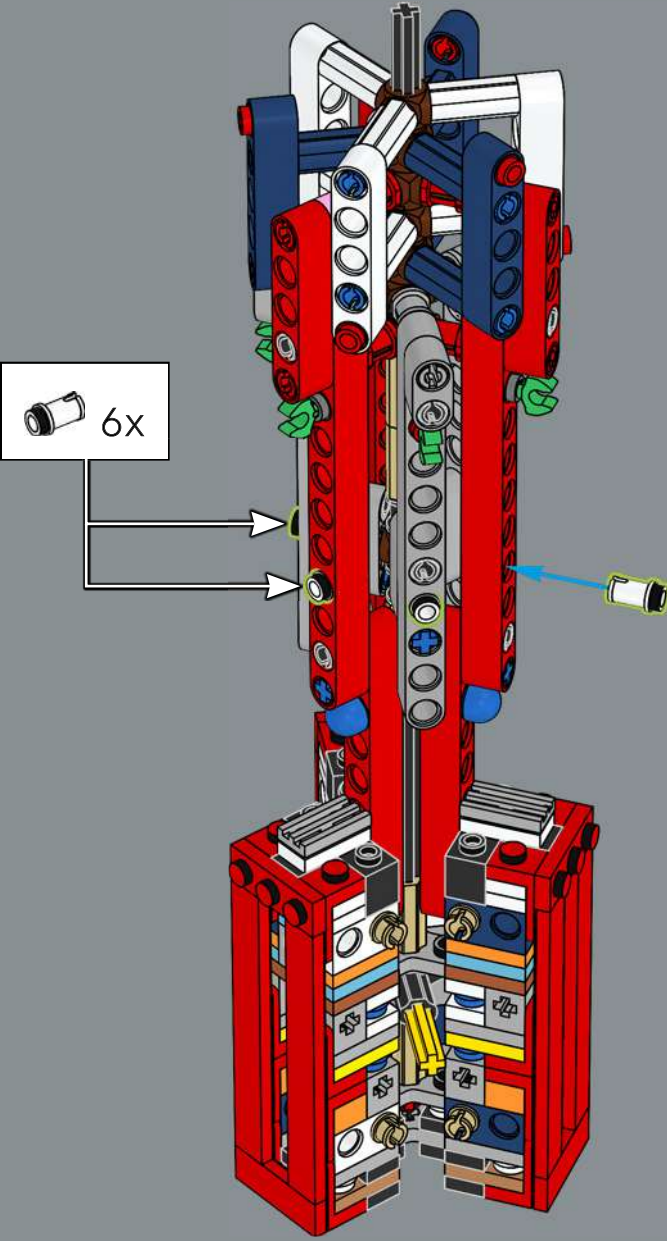



65

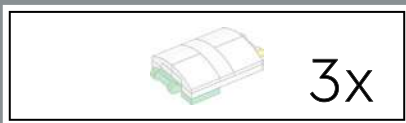
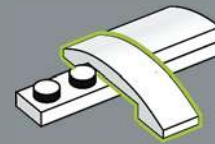

3x

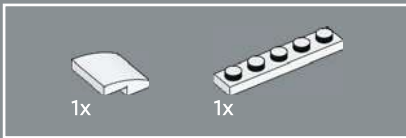

1x

1x

64

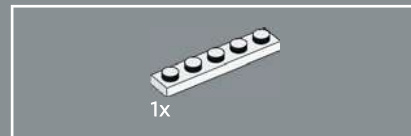
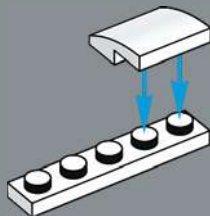

1x

66

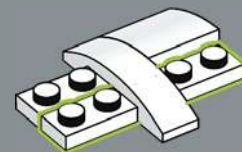



67

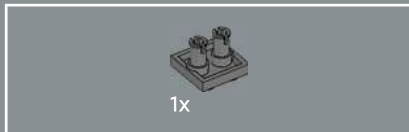
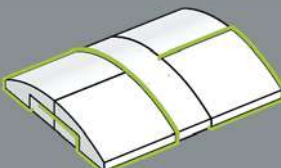

69

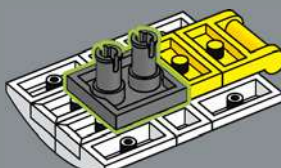

68

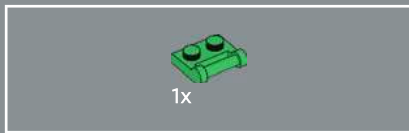
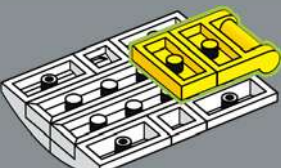

70

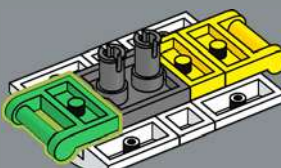

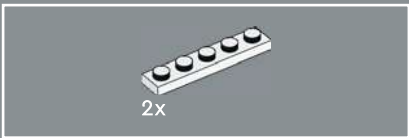

71

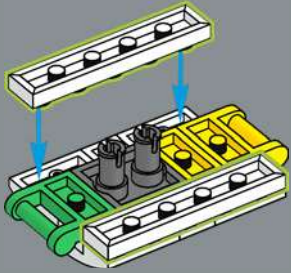

72

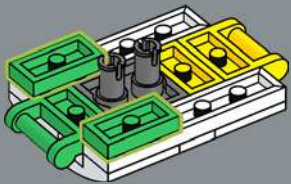

3x

73

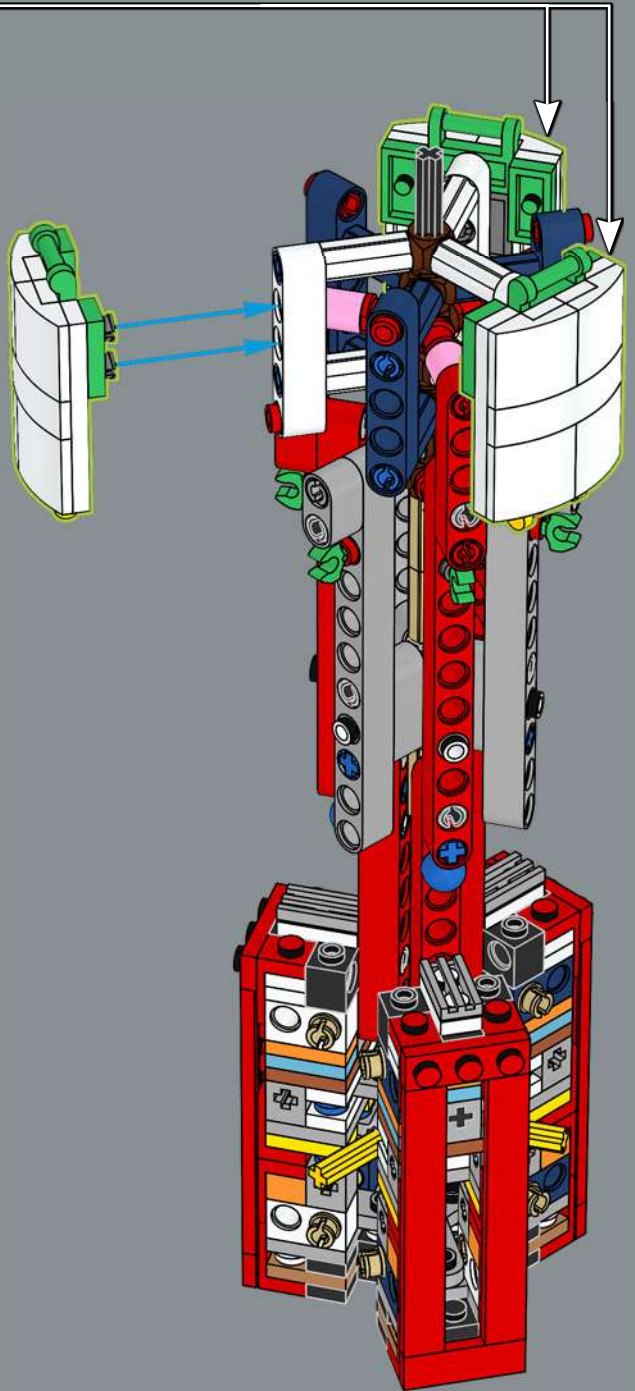

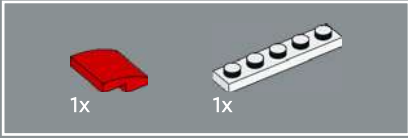

74

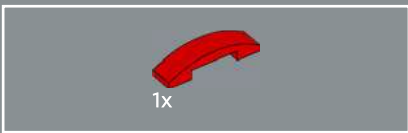
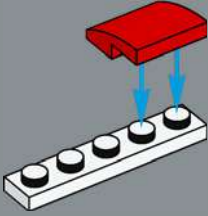

75

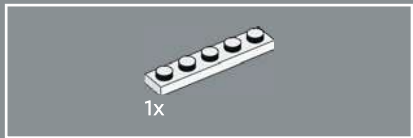
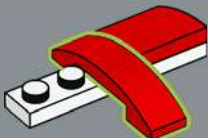

76



77

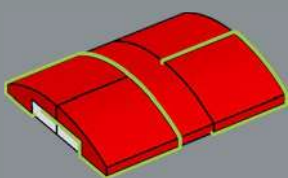

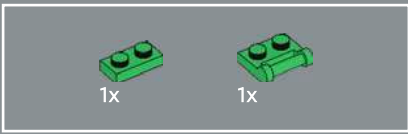

78

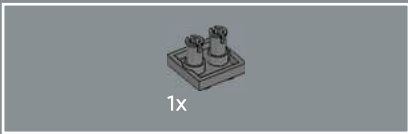
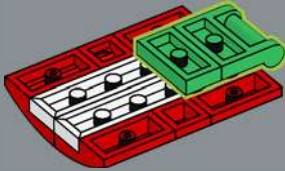

79

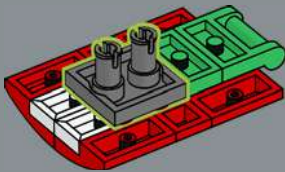

80

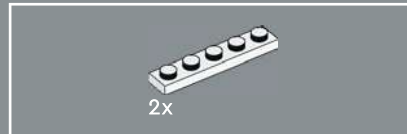
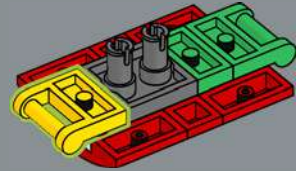

81

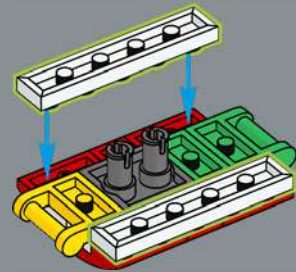

3x

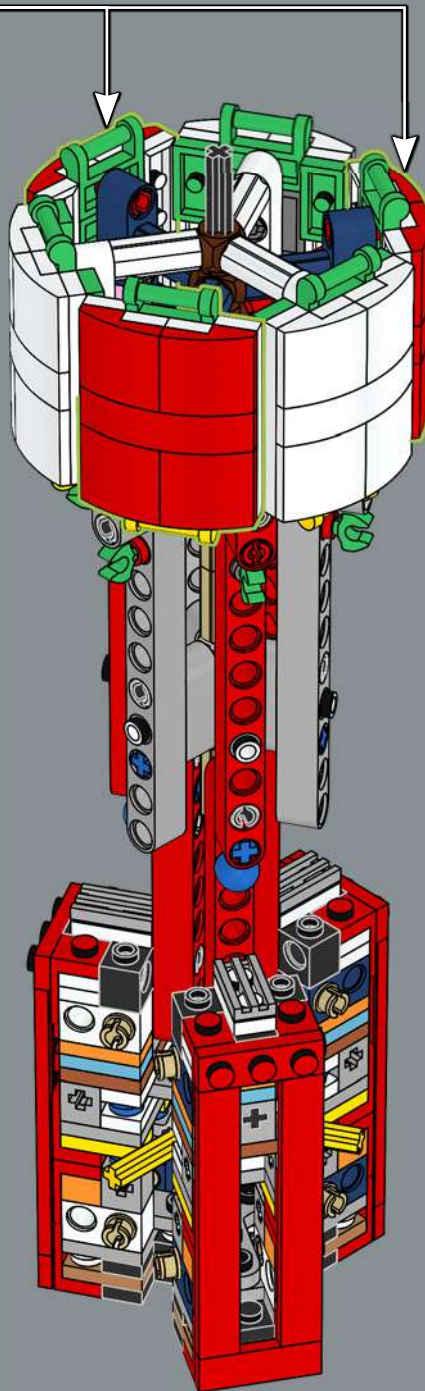

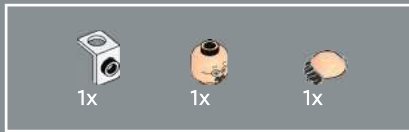

2

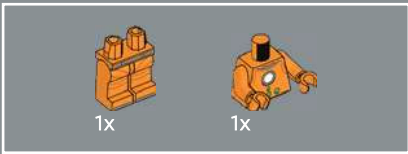
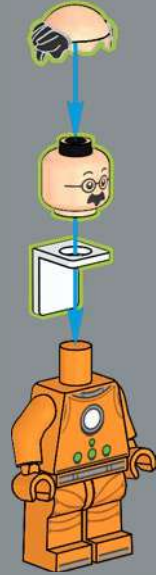

1

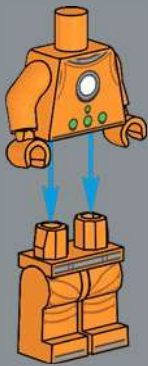

3

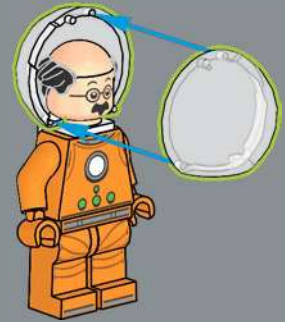



4

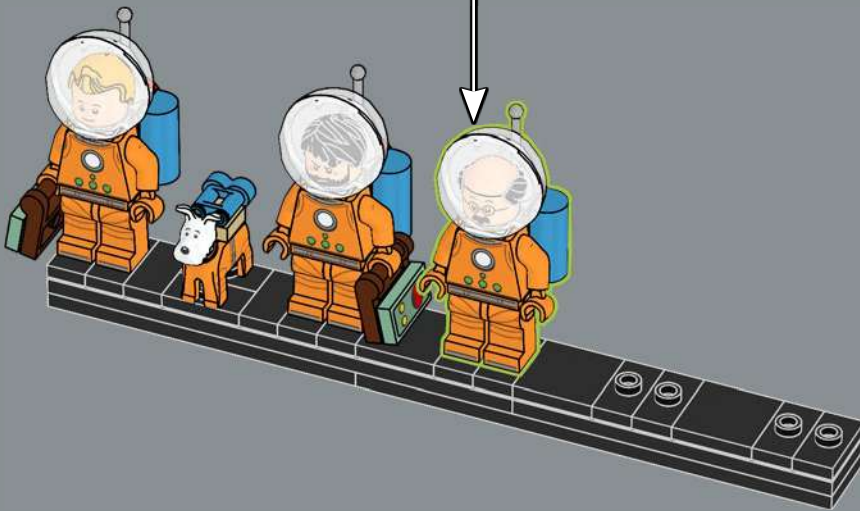
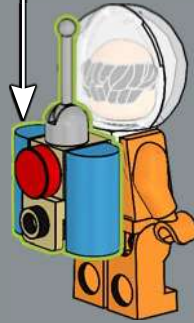
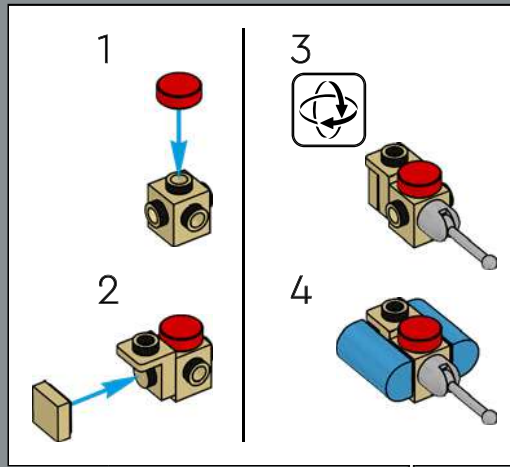

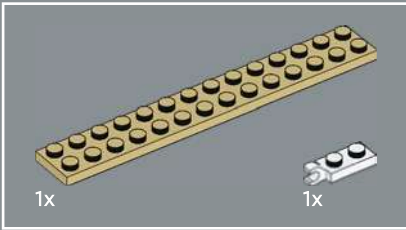
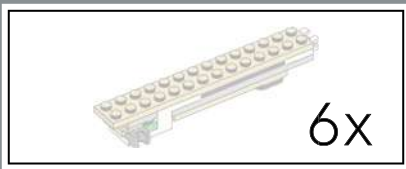

83

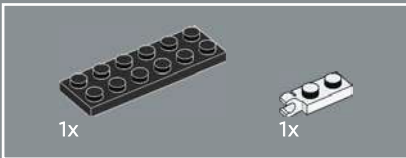
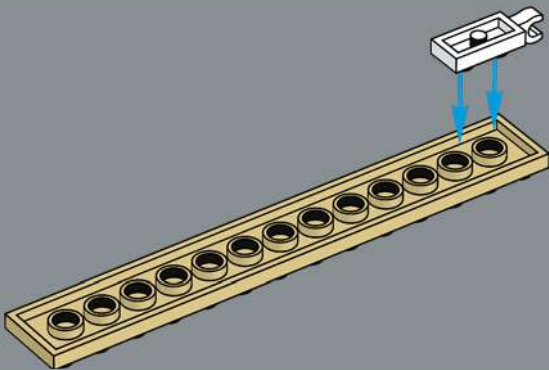

84

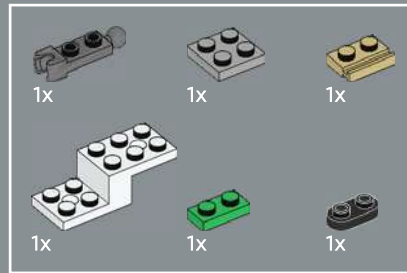
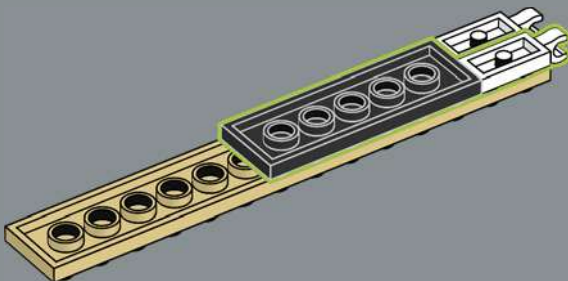

85

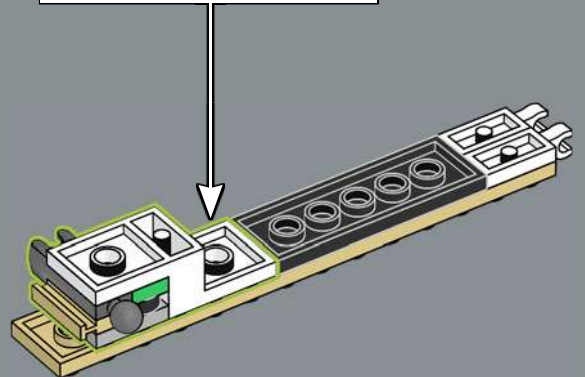
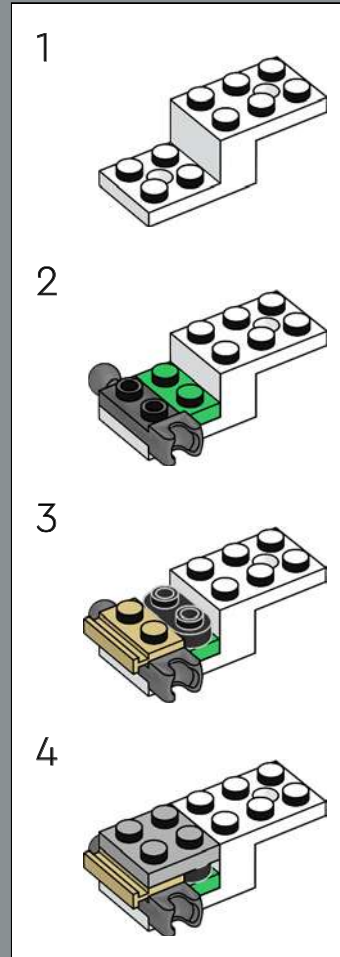

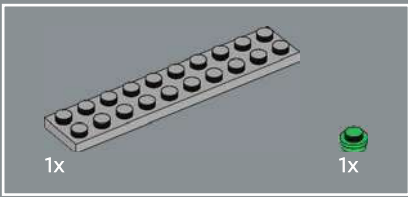

86

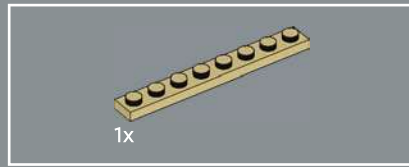
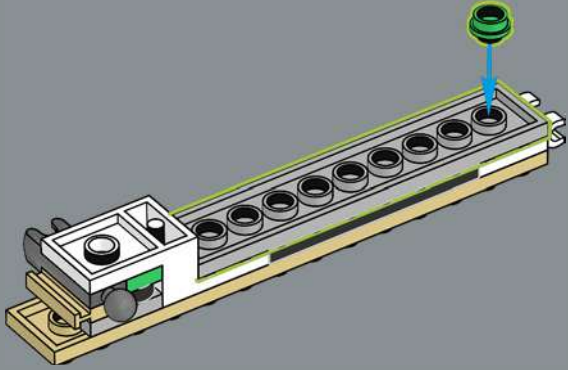

88

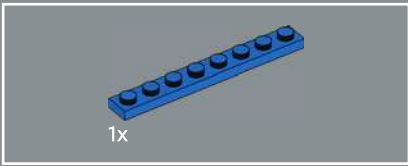
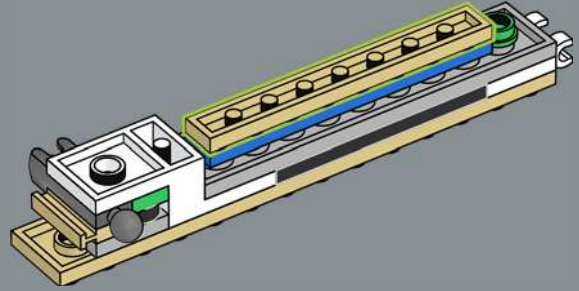

87

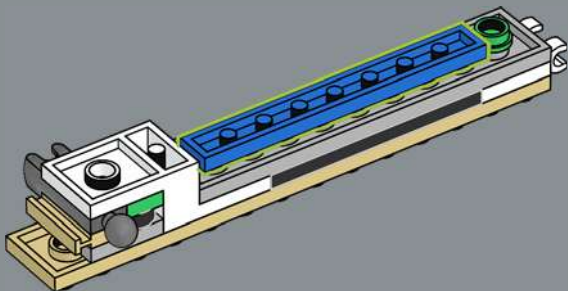

89

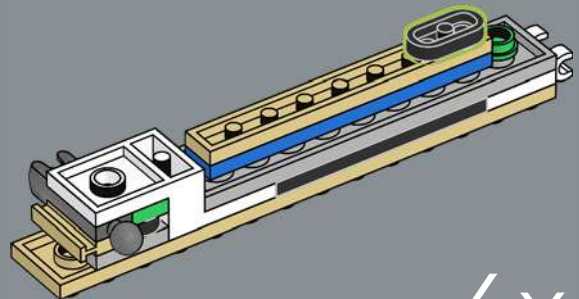

6x



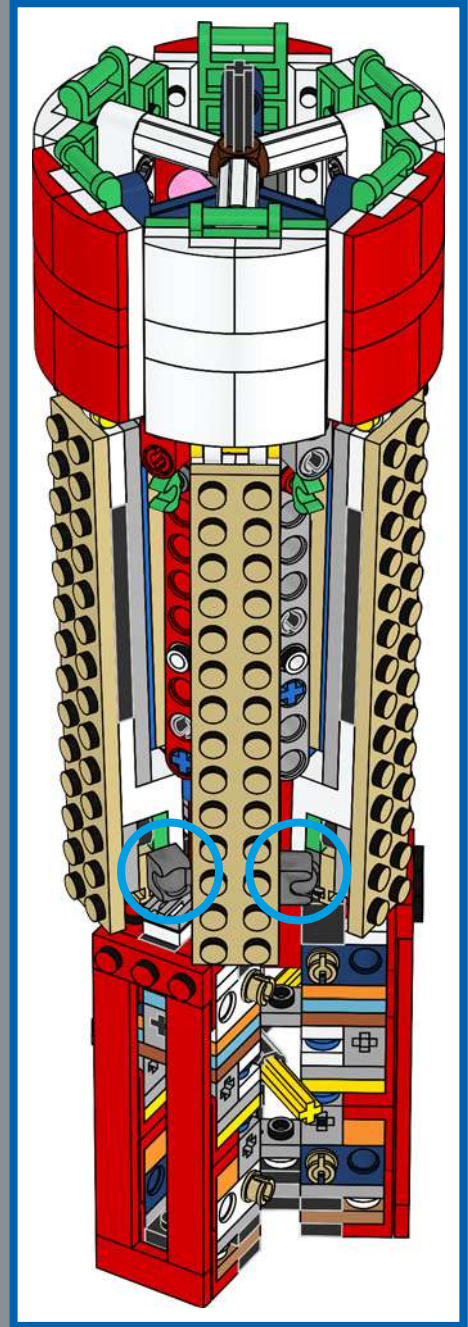
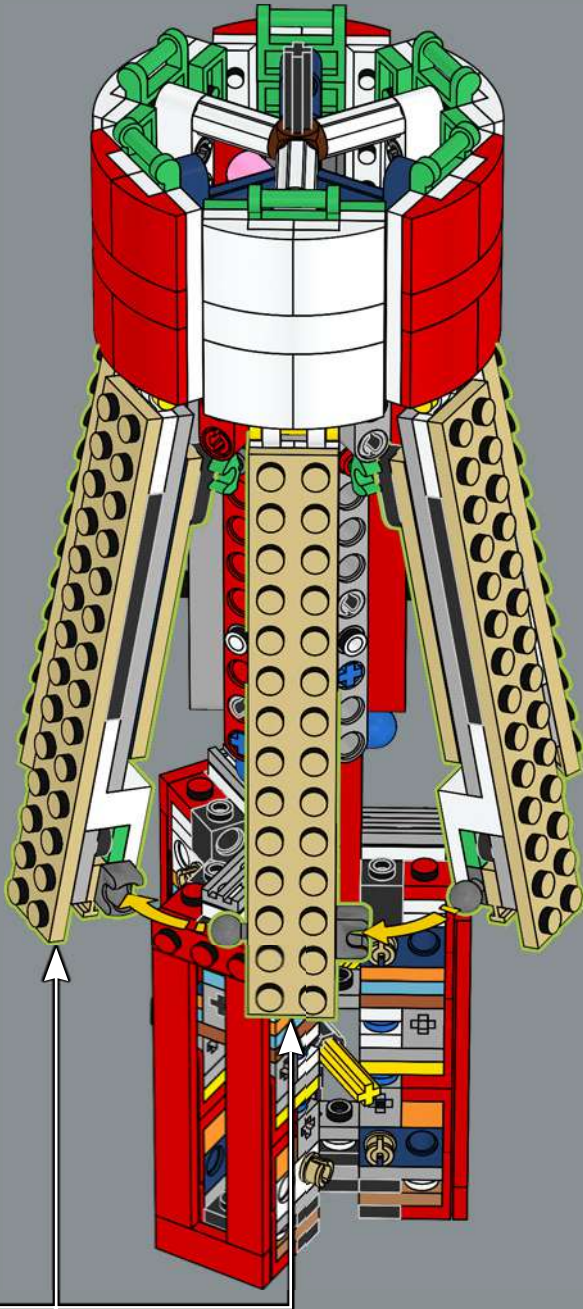

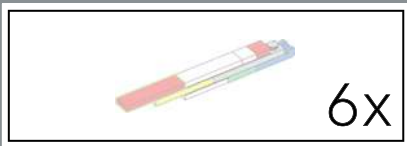

6x

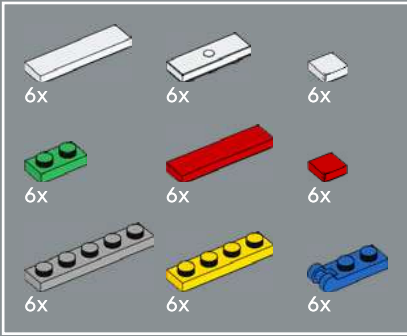

91

1

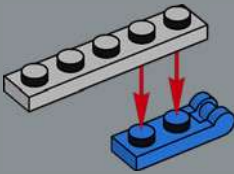

2

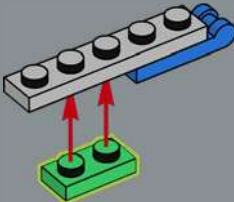

3

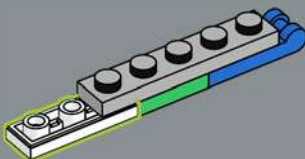

4

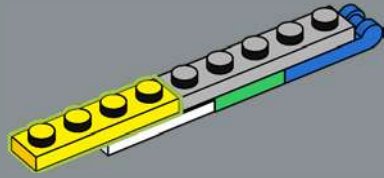

5

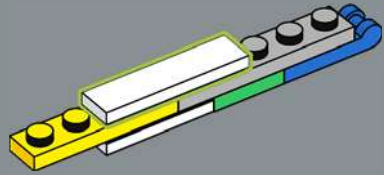

6

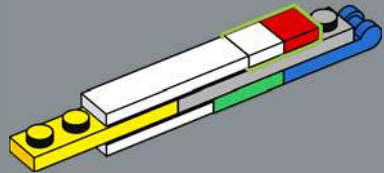

7

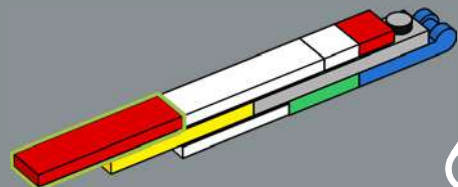

6x



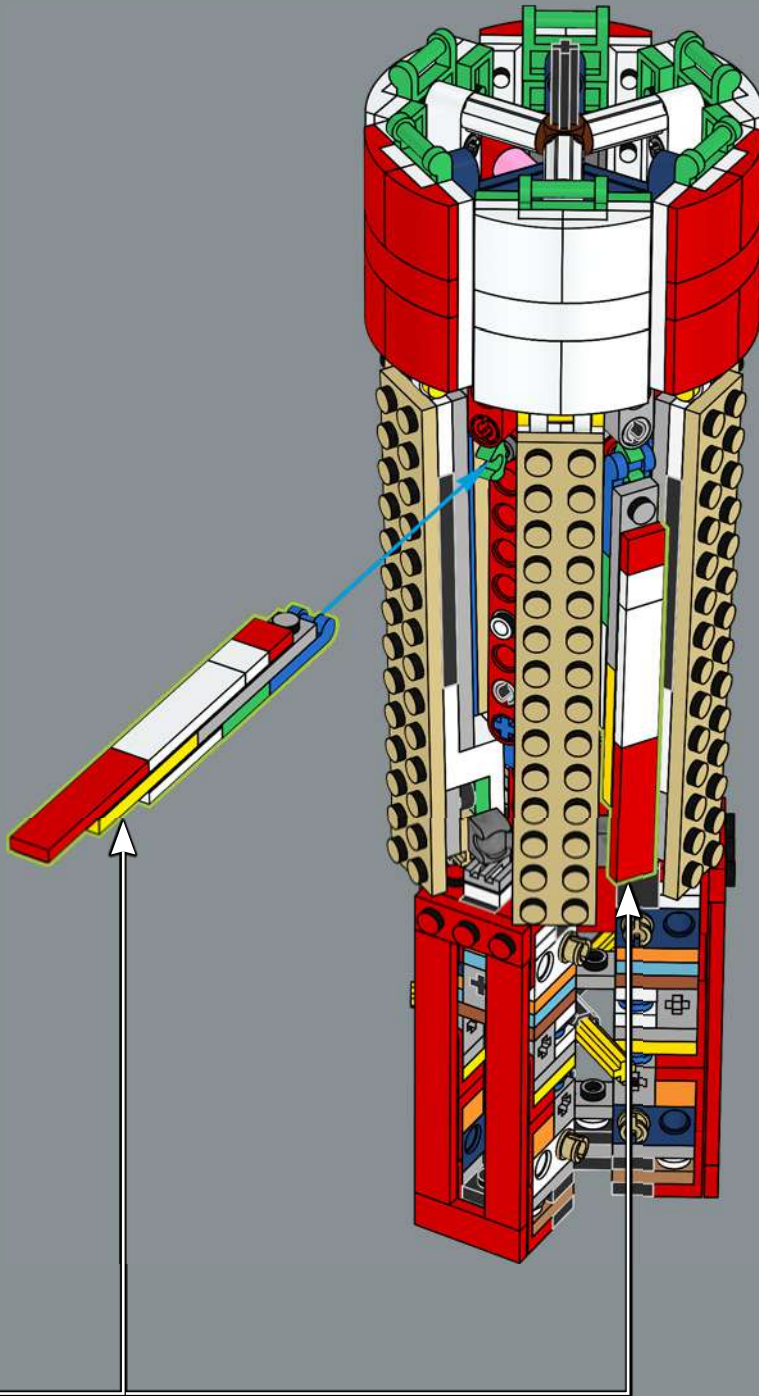

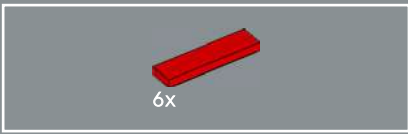

92

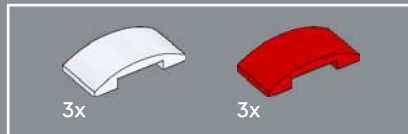
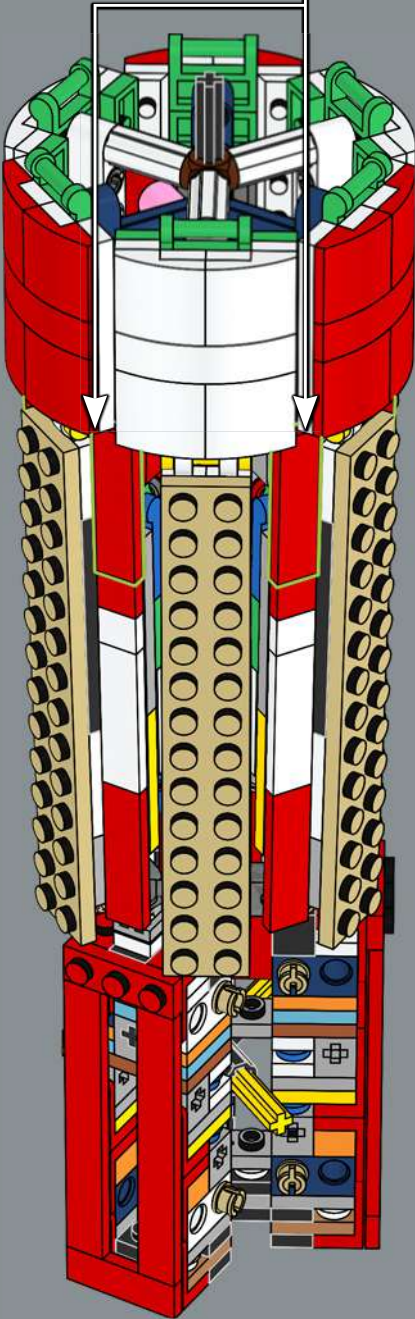
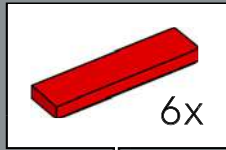

93

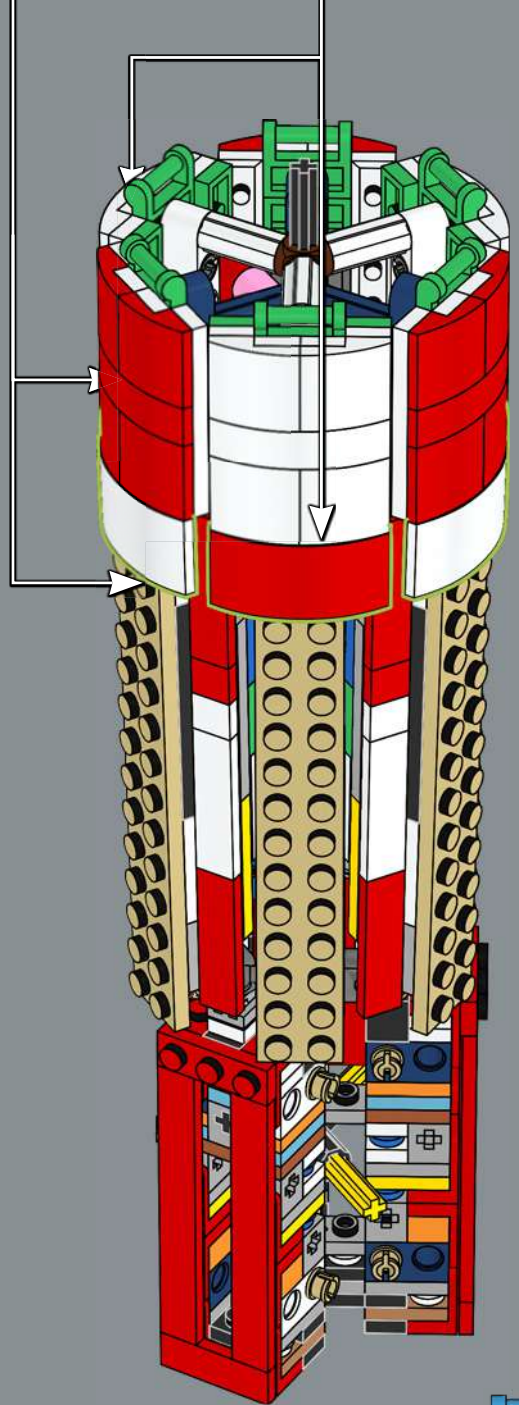
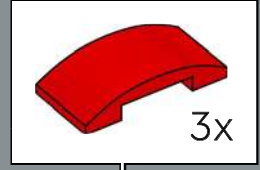
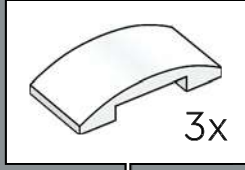

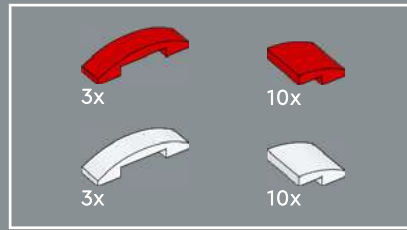

94

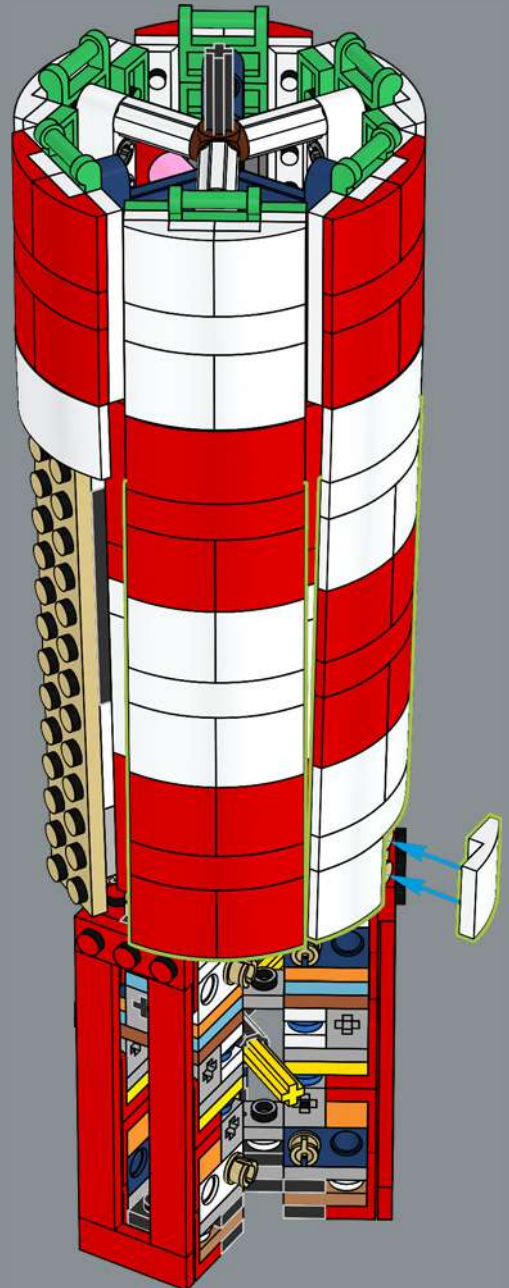

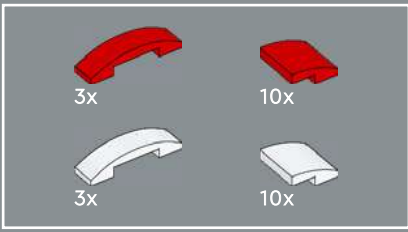

95

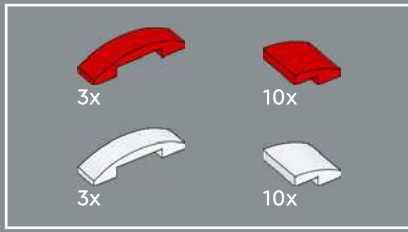
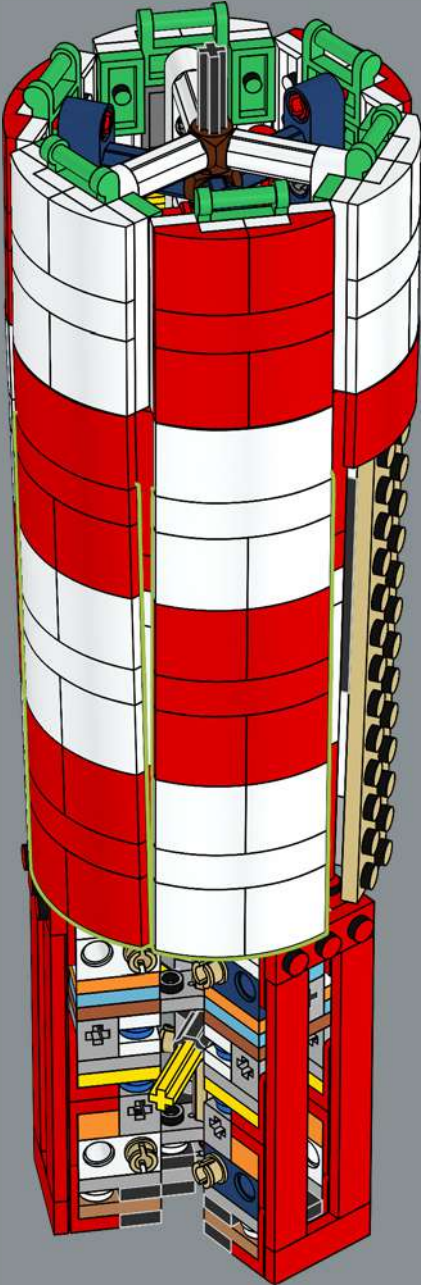

96

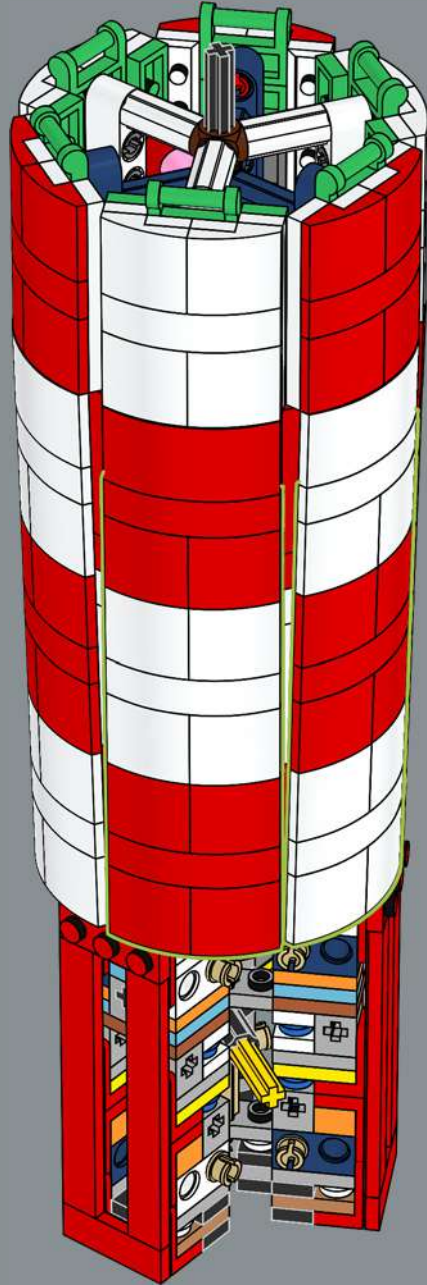



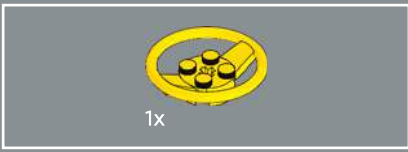

97

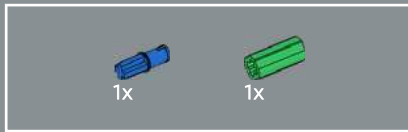
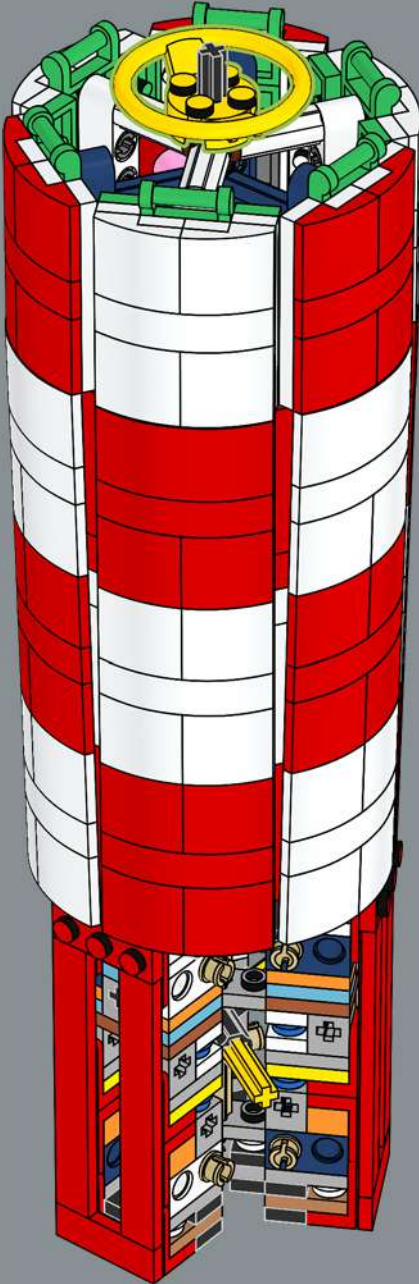

98

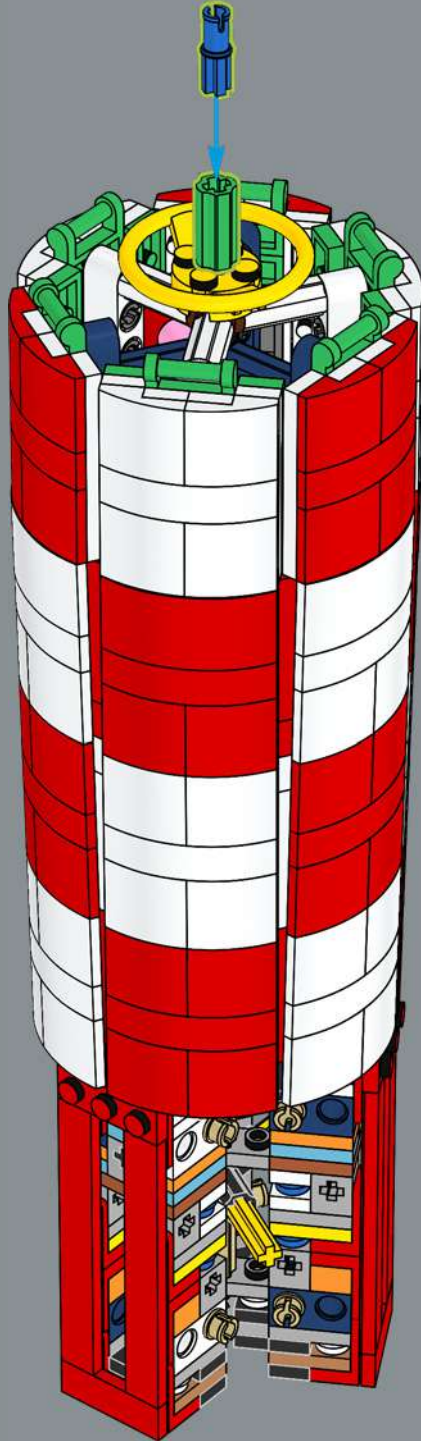

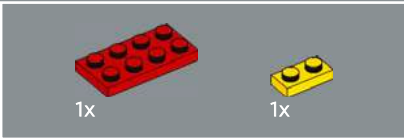
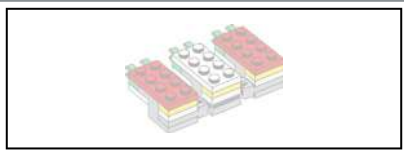

99

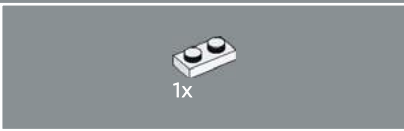
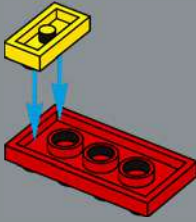

100

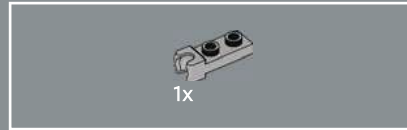

101

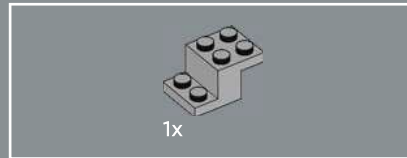
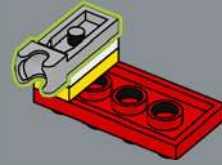

102

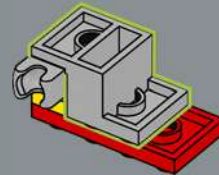



103

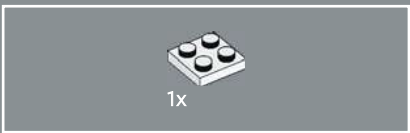
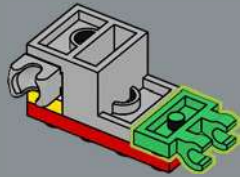

104

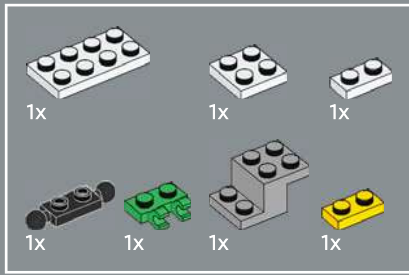
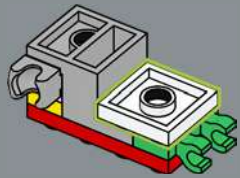

105

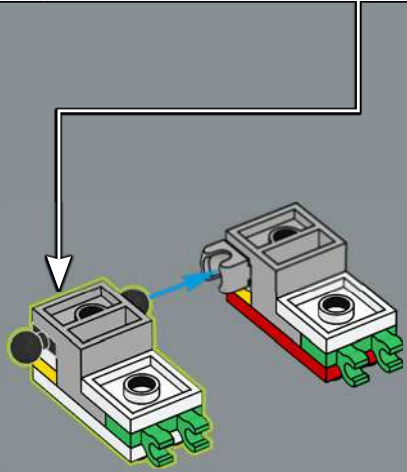
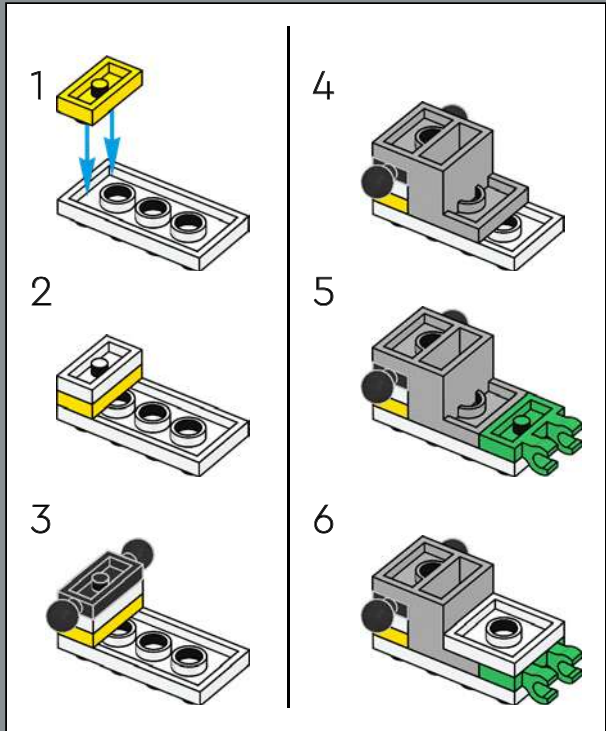

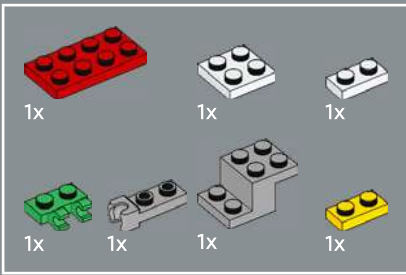

106

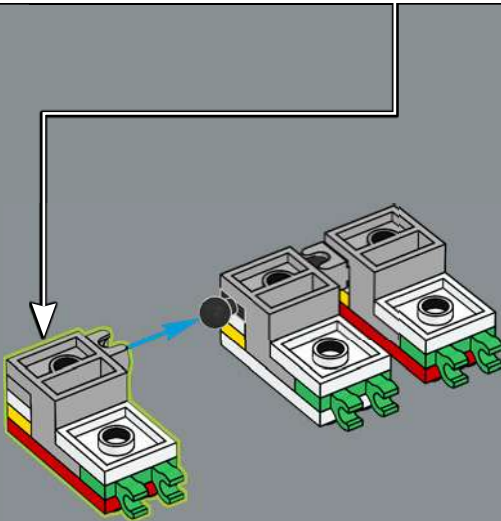
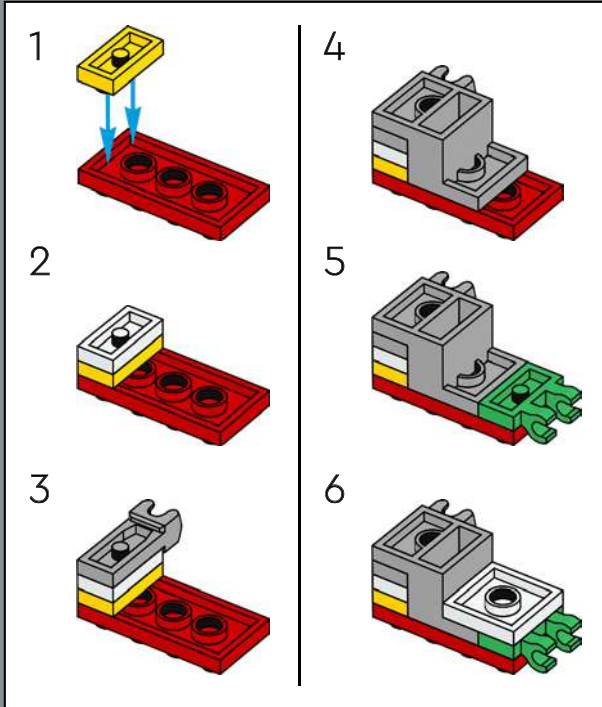

107

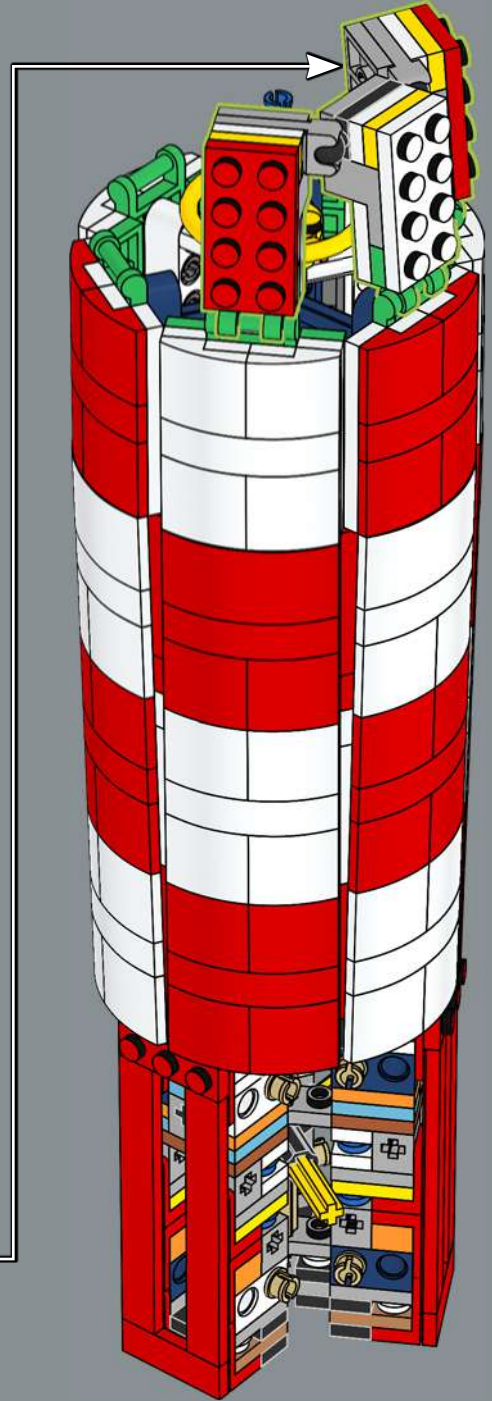

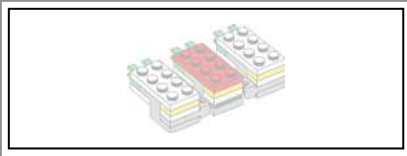

108

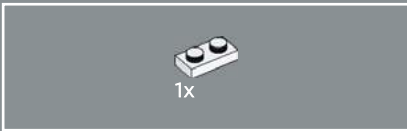
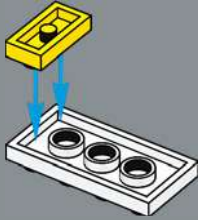

109

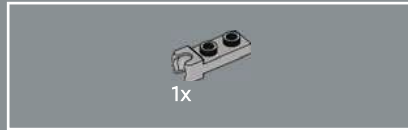

110

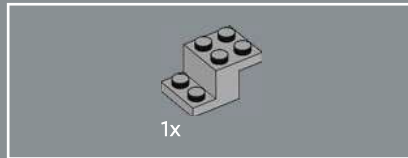
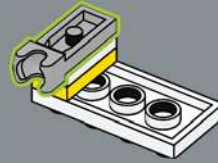

111

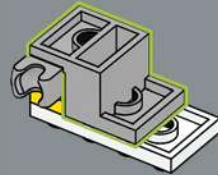



112

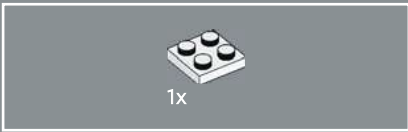
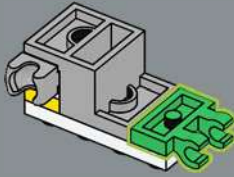

113

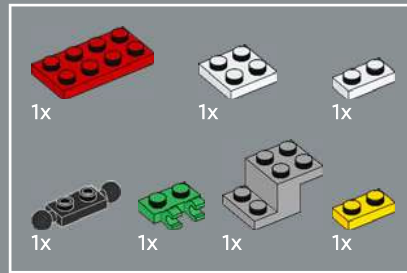
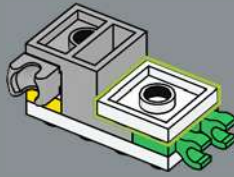

114

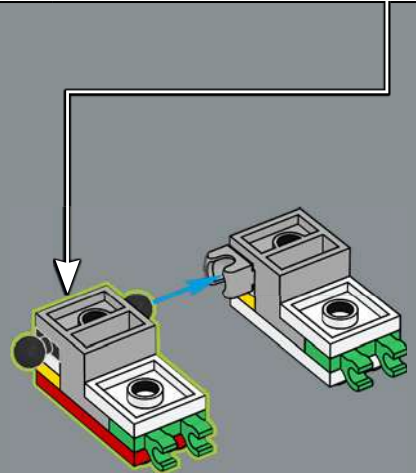
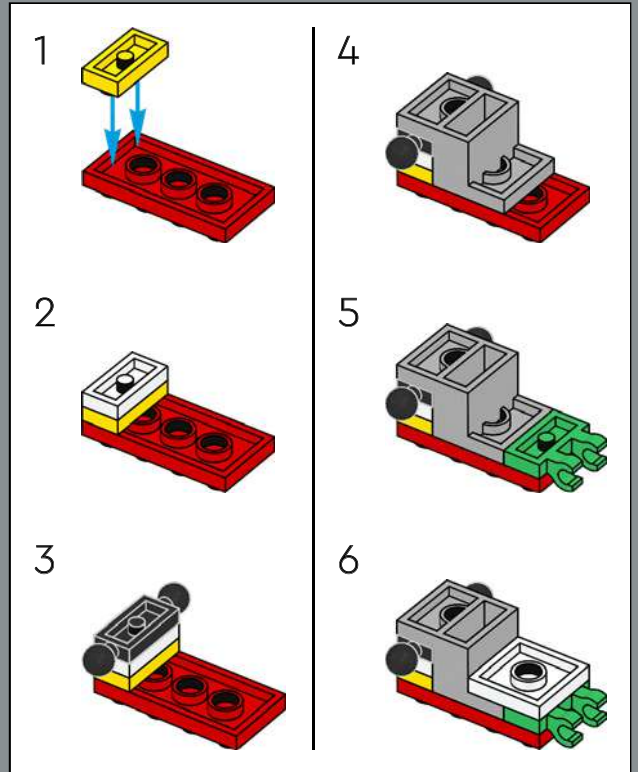

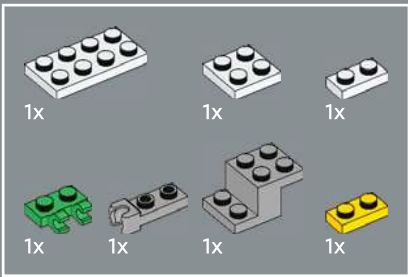

115

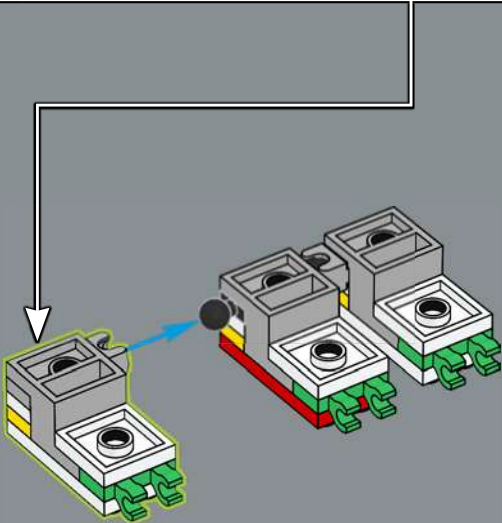
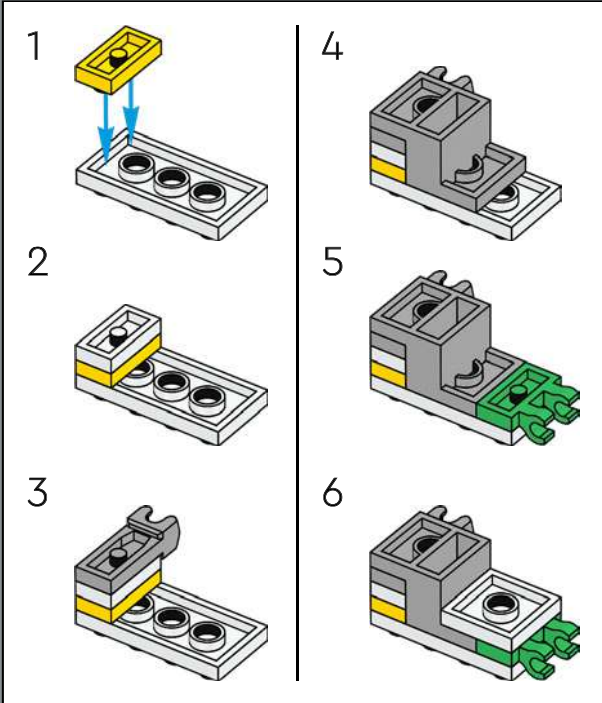

116

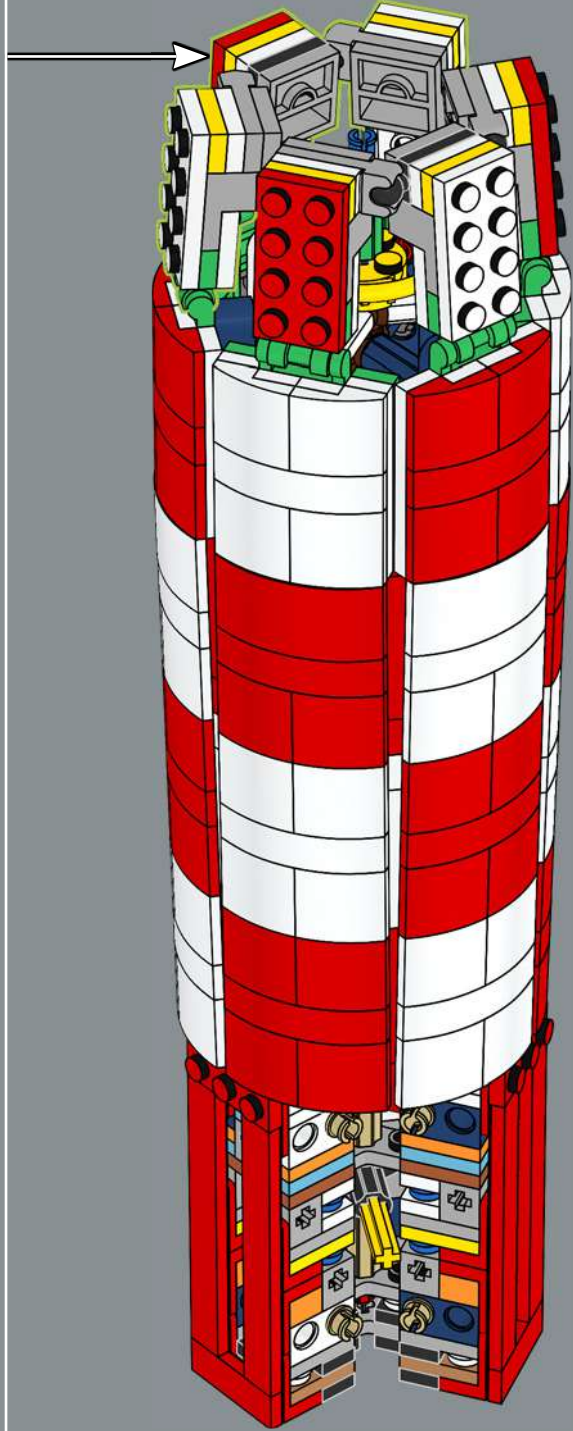

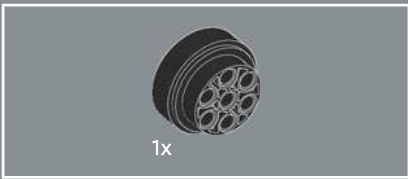

117

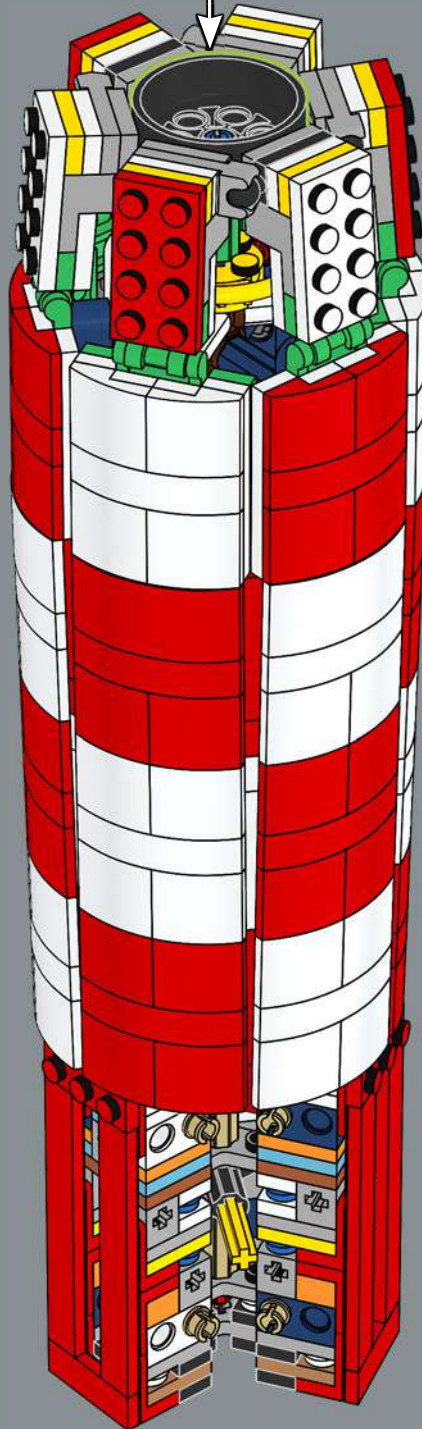

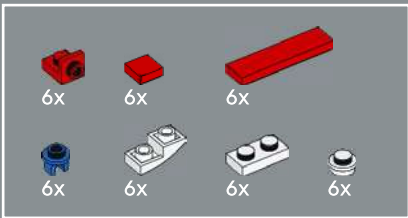

118

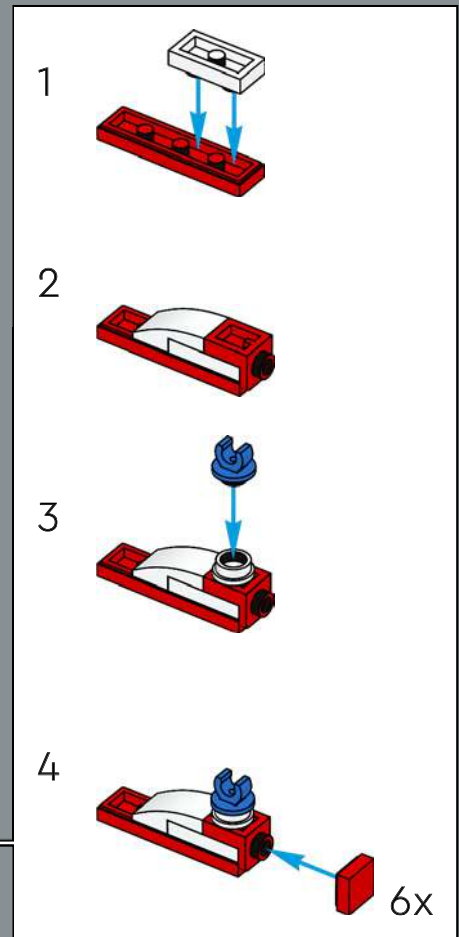
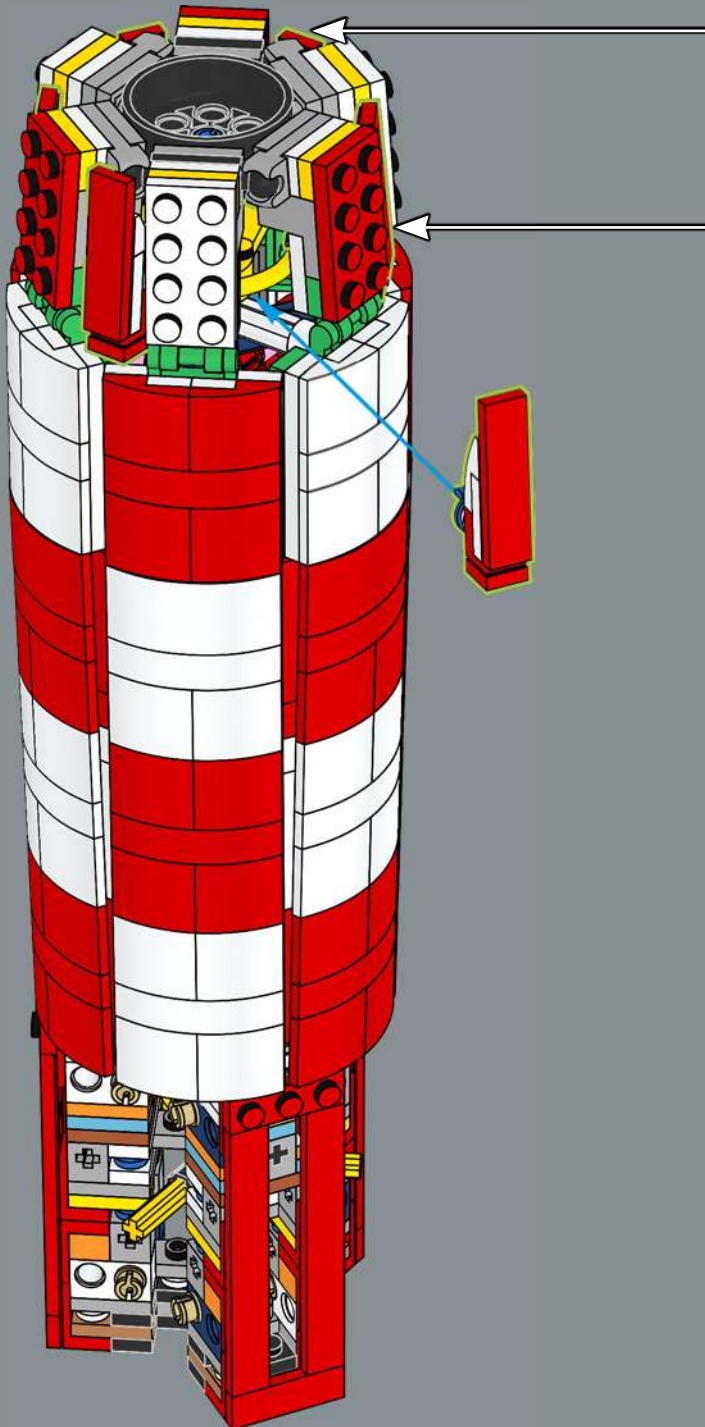

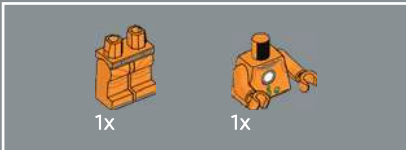

1

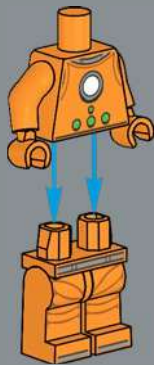

2

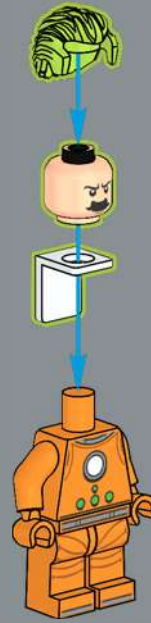

3

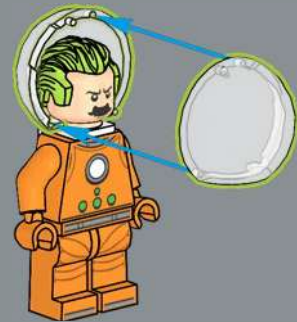



4

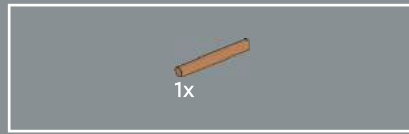
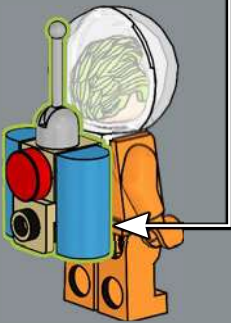
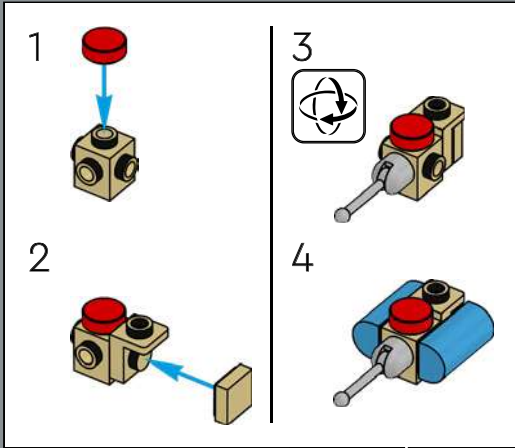

5

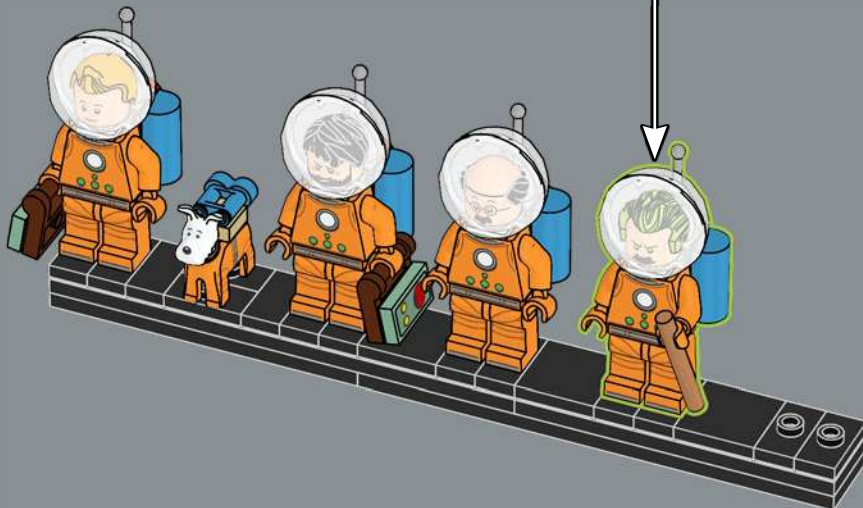
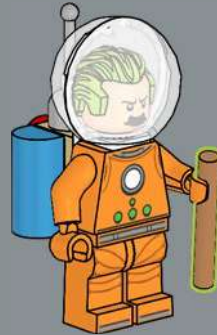

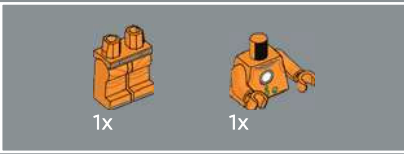

1

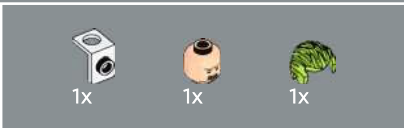
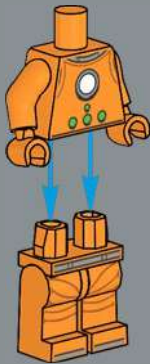

2

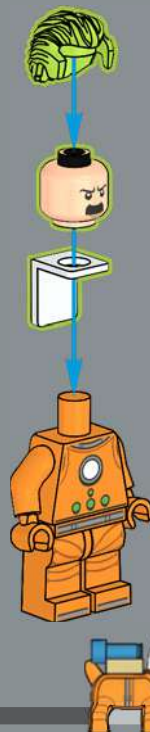

3

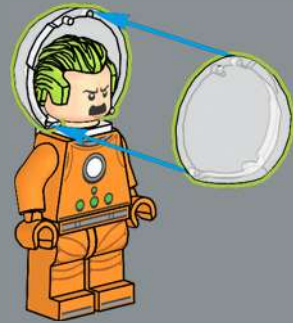

4

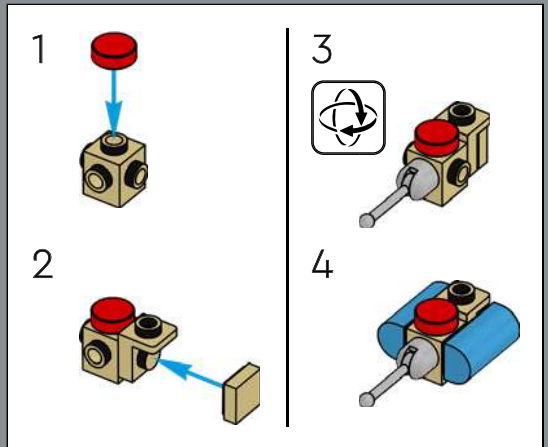

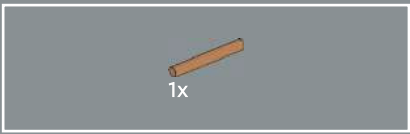

5

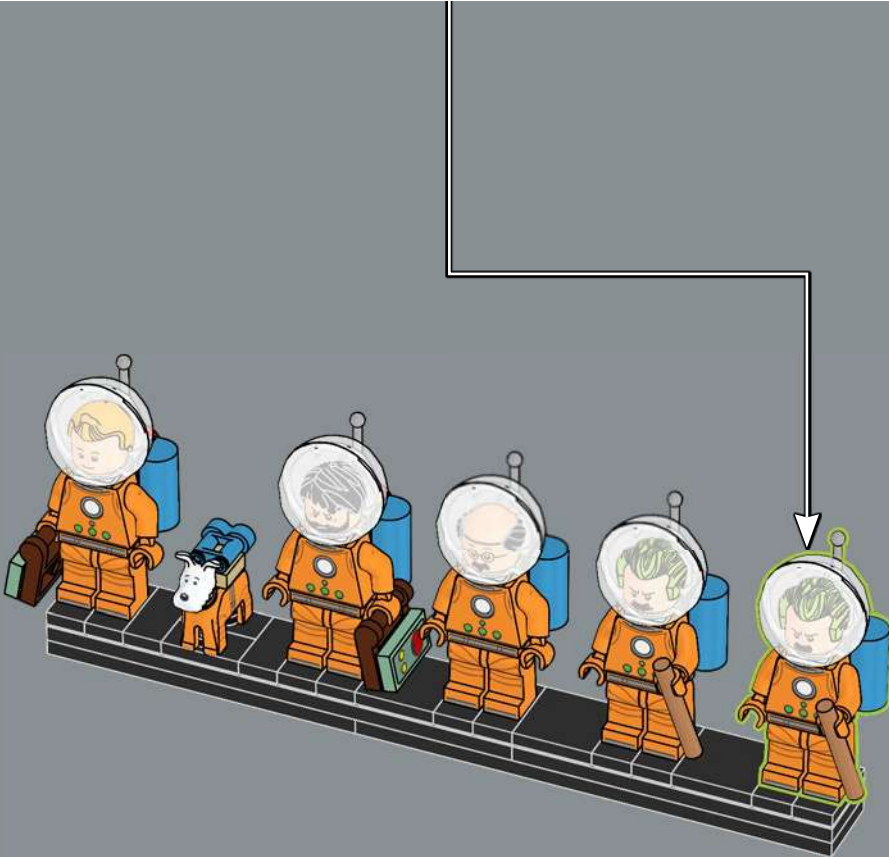

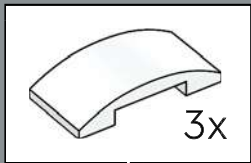
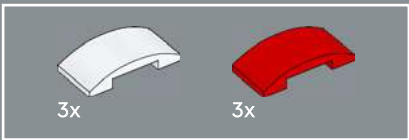

119

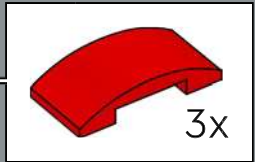
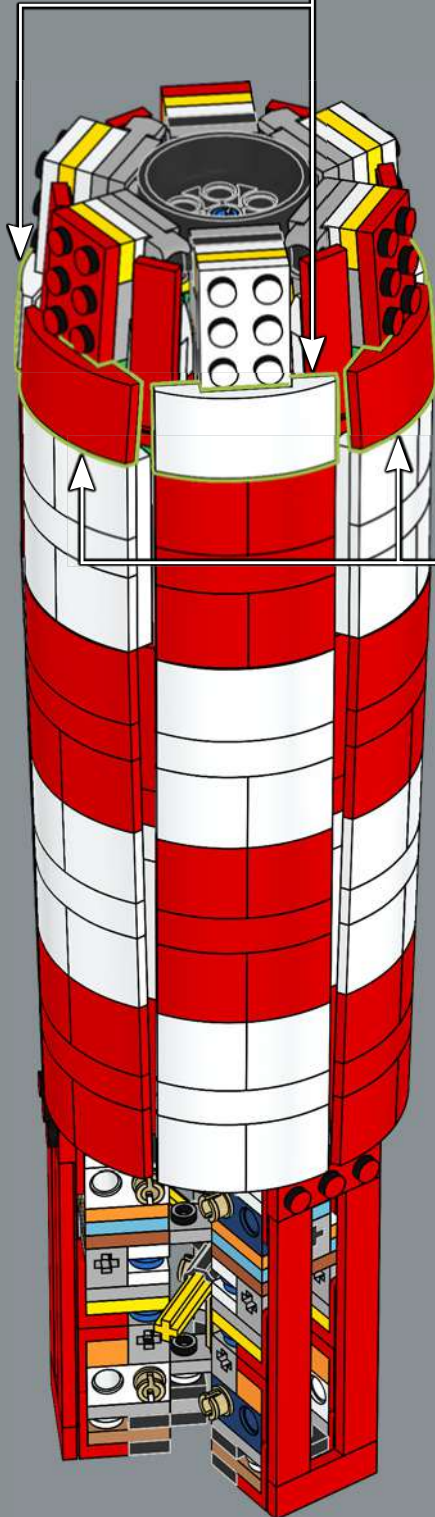

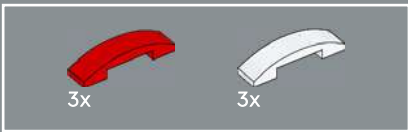

120

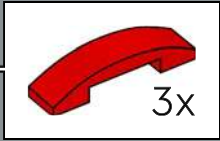
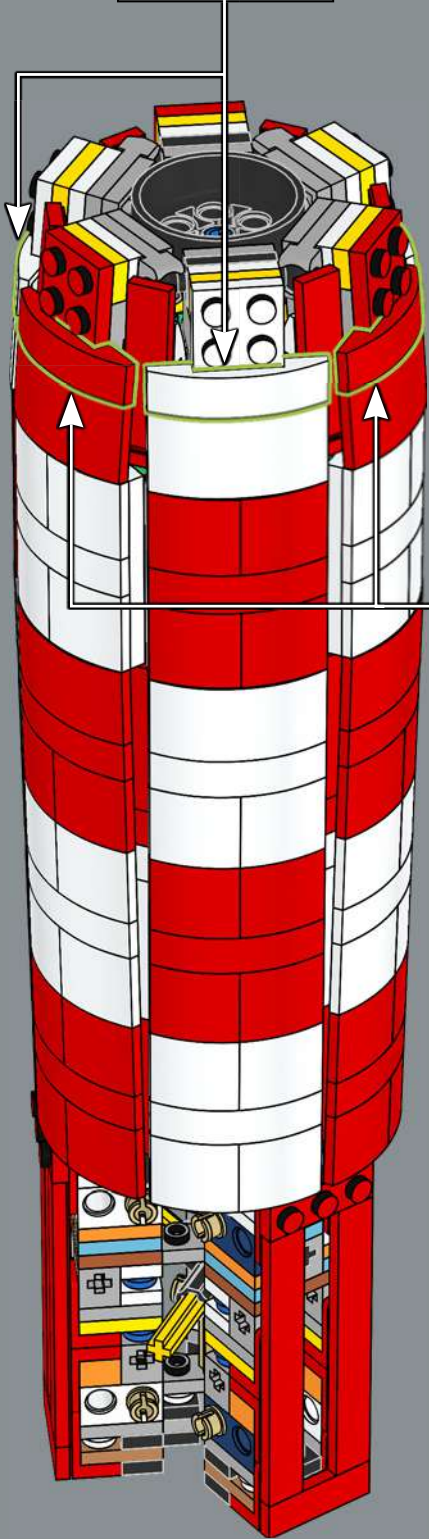
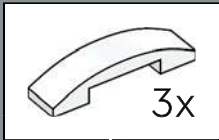

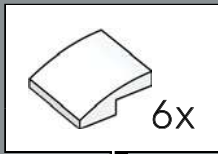
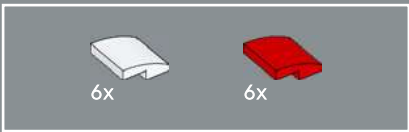

121

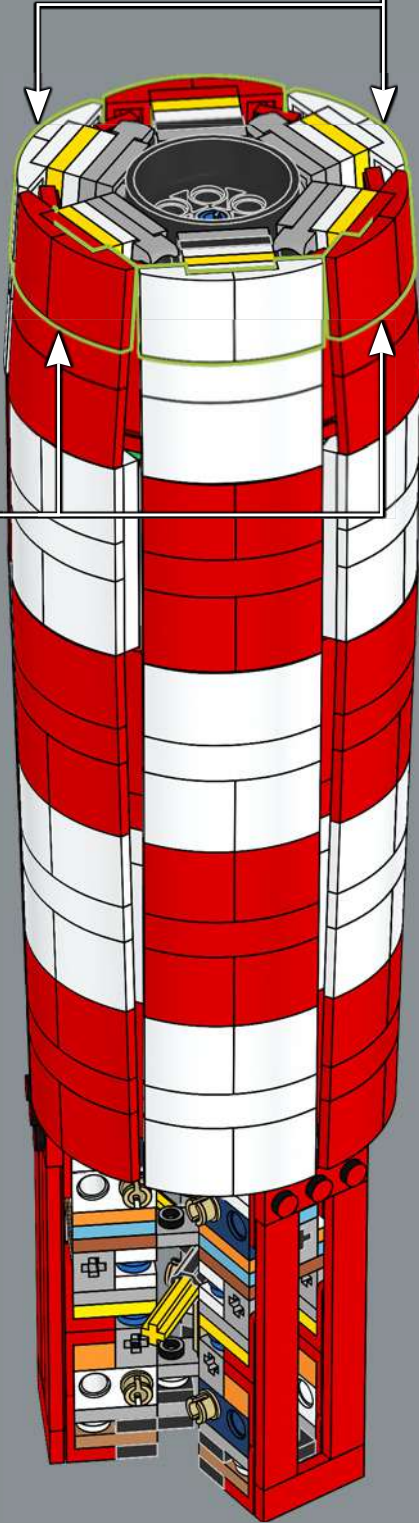

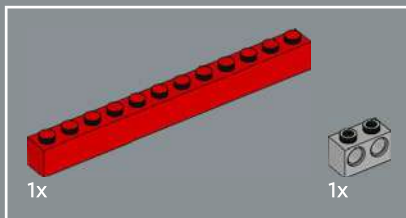

122

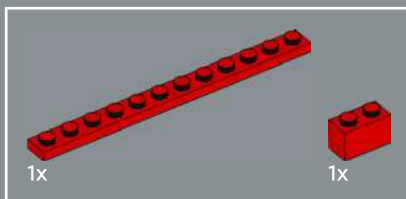
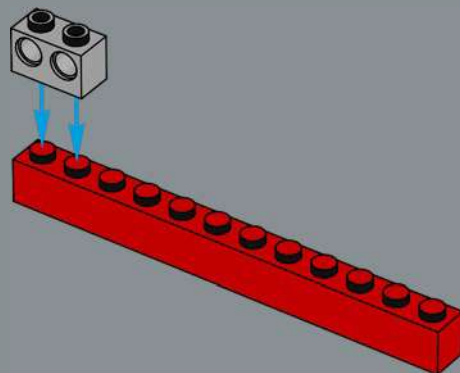

123

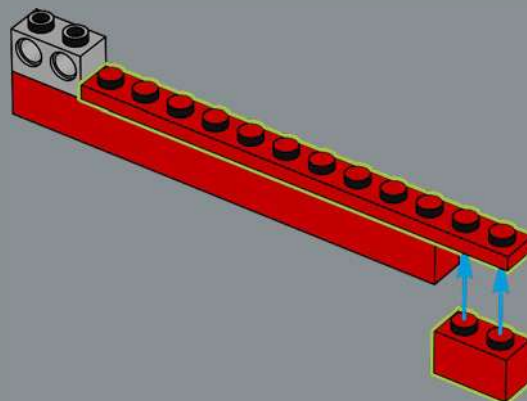

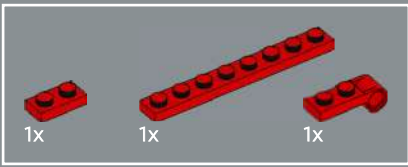

124

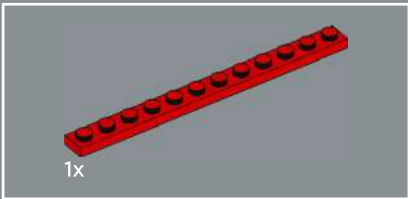
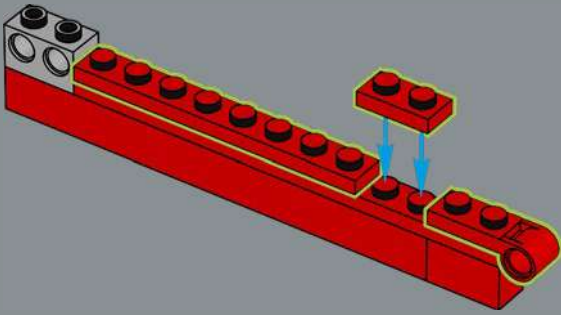

125

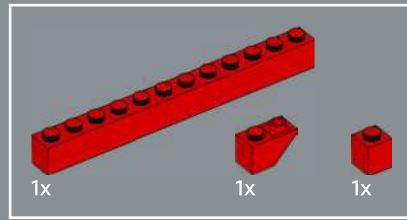
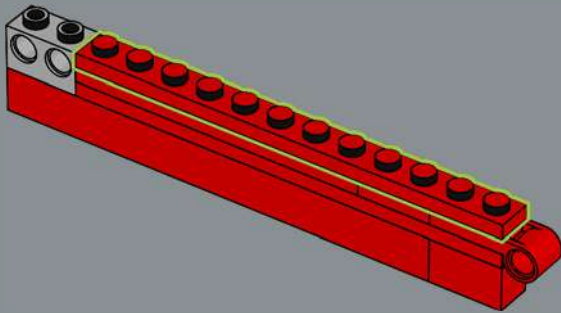

126

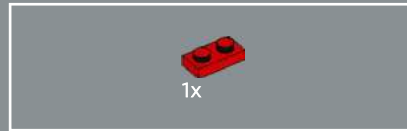
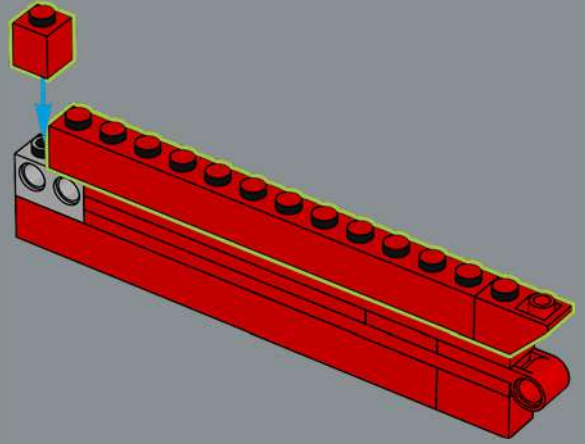

127

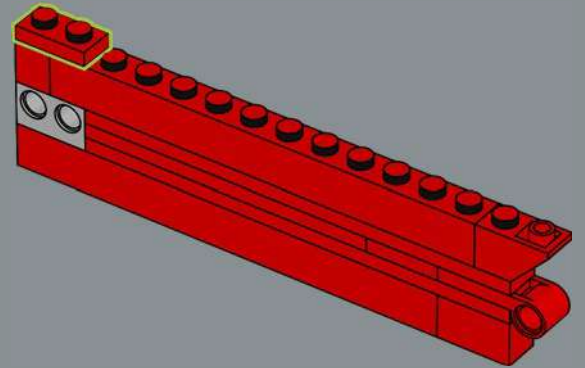

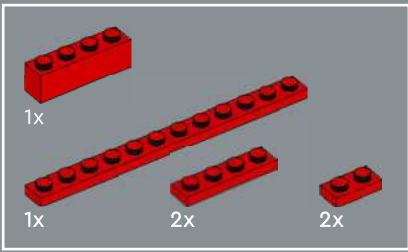

128

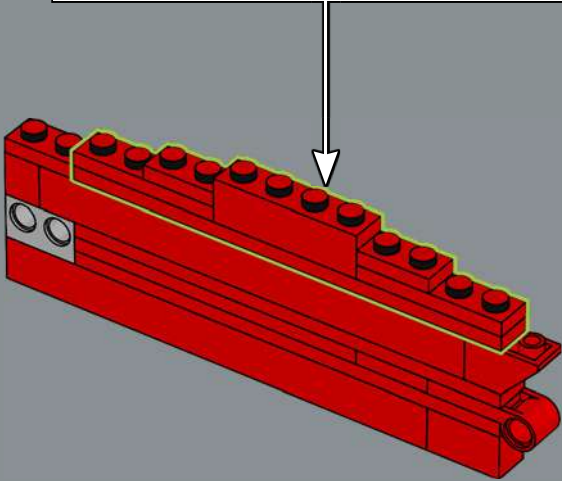
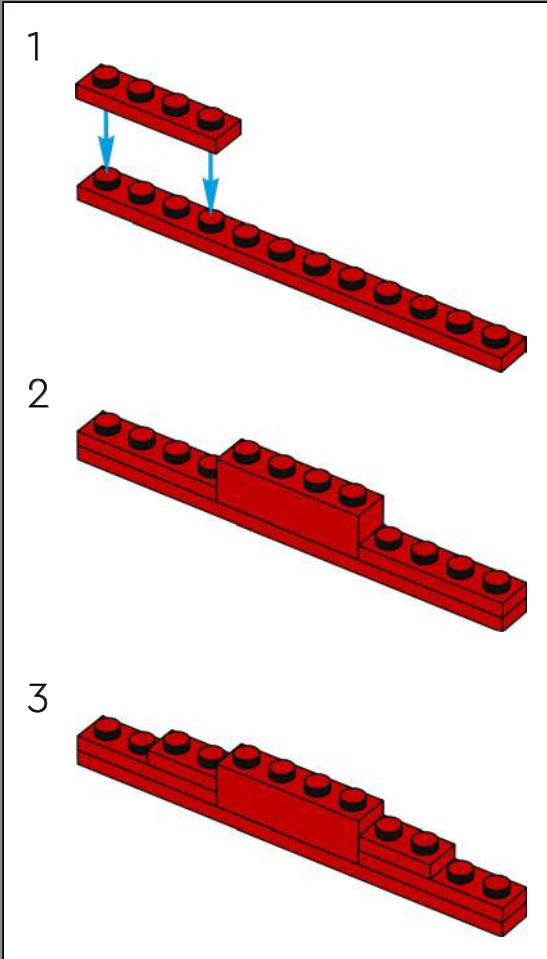

129

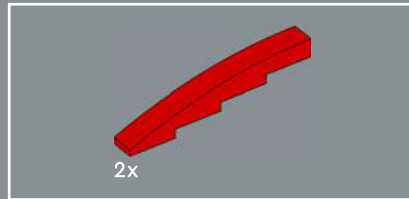
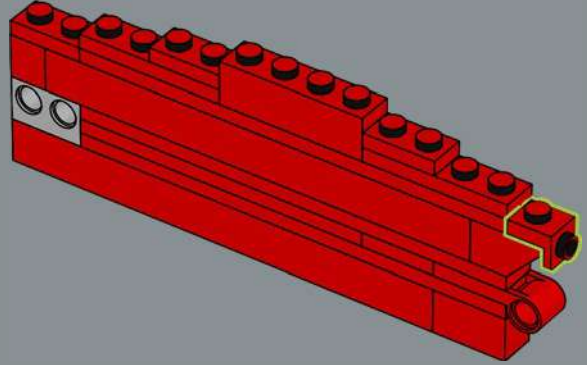

130

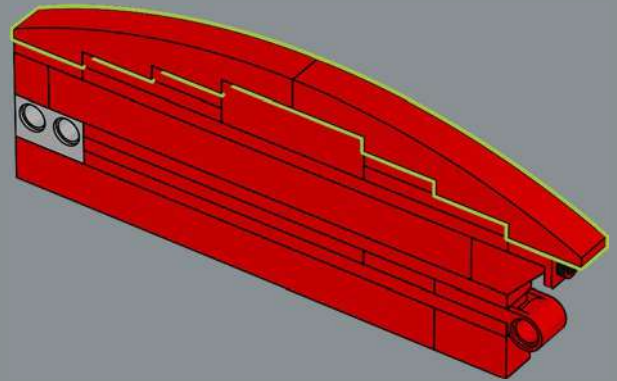

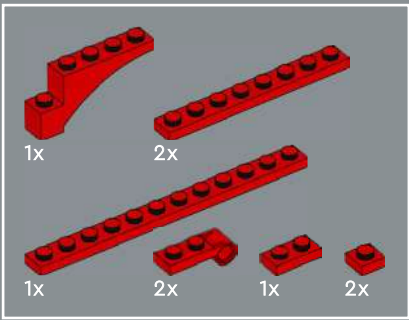

131

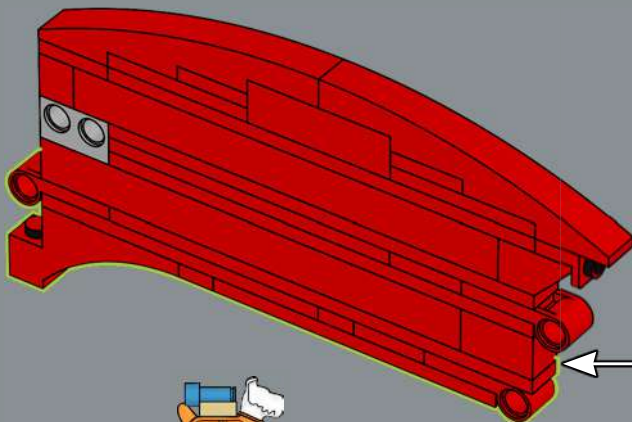
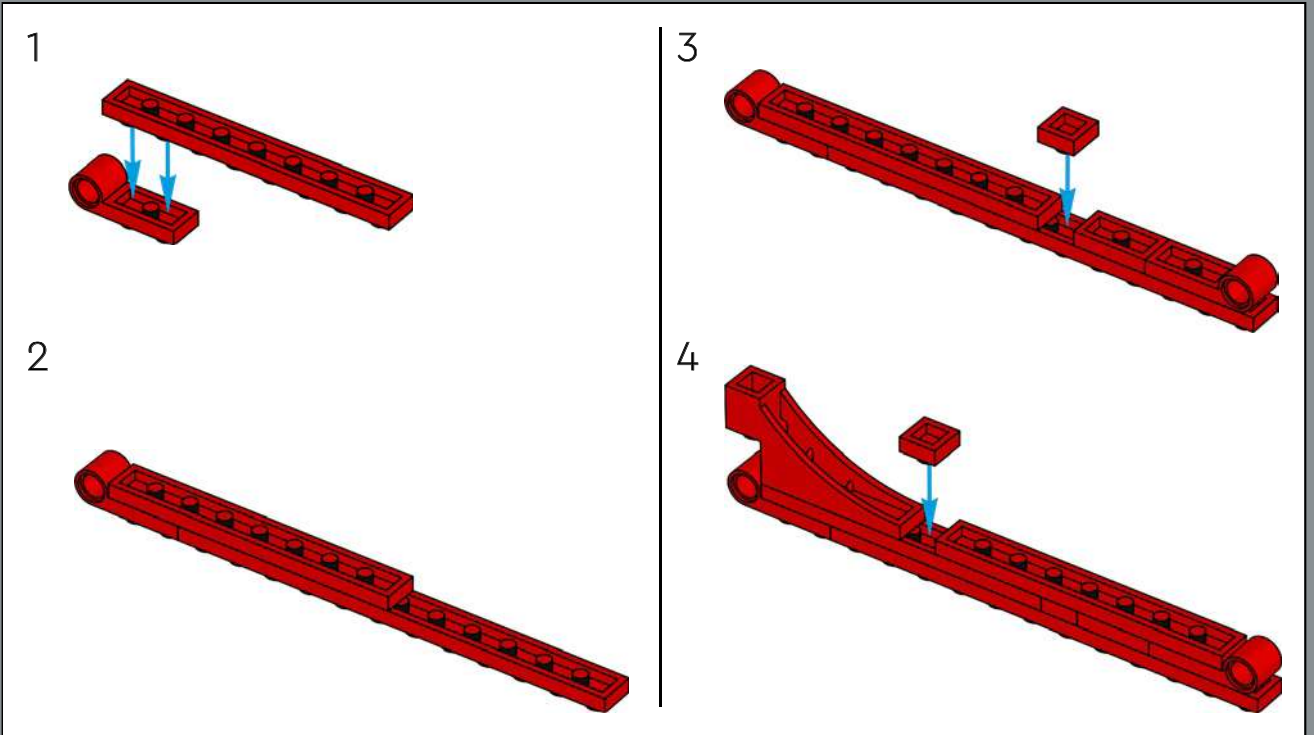

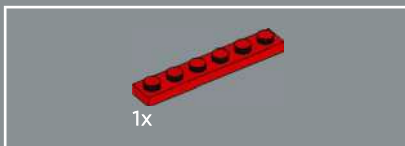

133

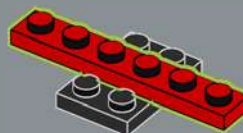

134

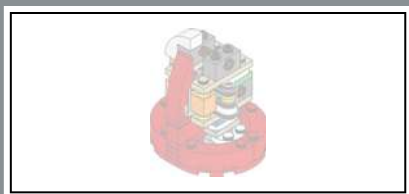
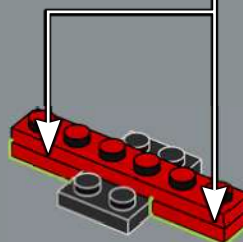

132

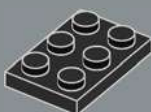



135

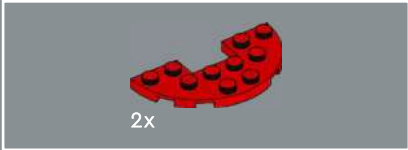
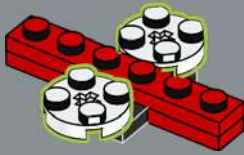

136

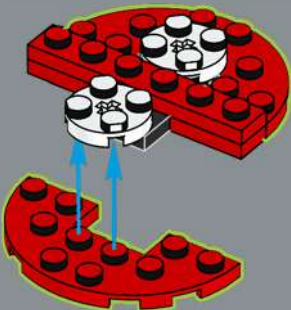

137

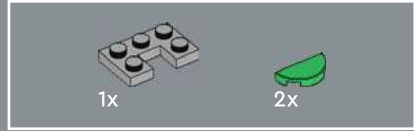

138

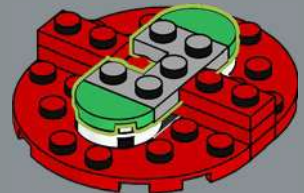

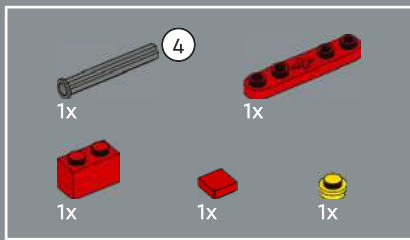

139

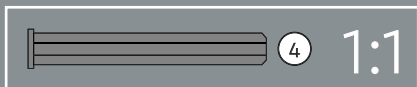
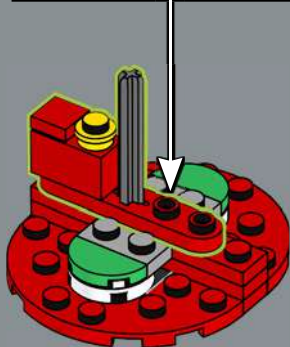
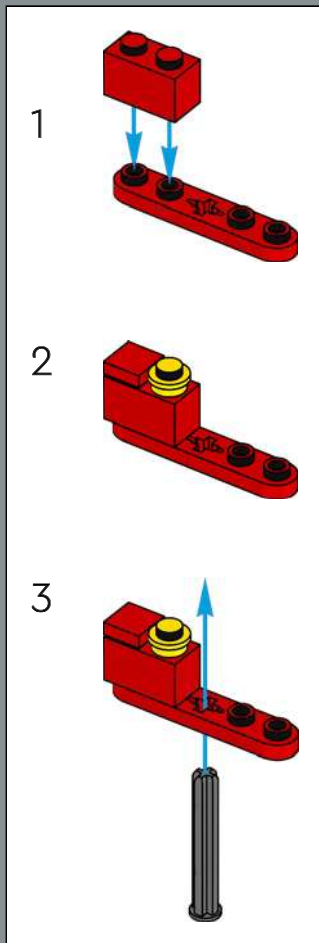

140

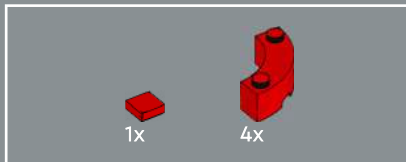
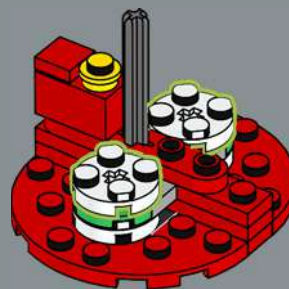

141

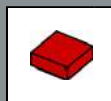
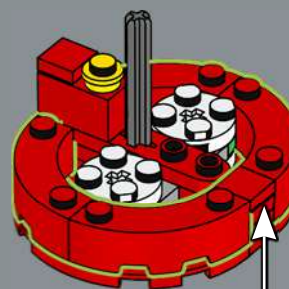

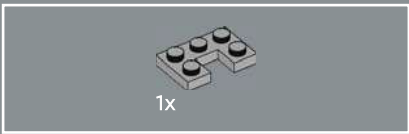

142

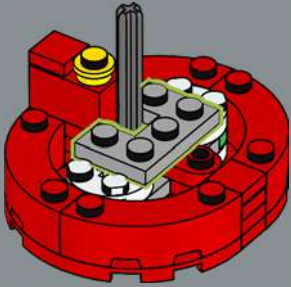

143

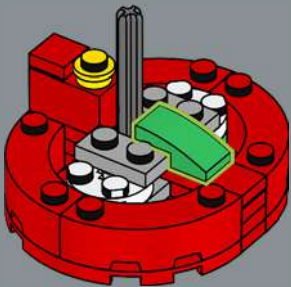

144

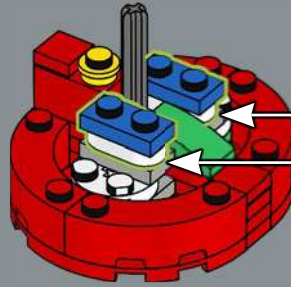
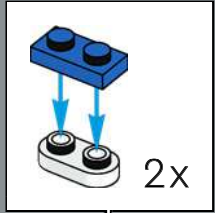

145

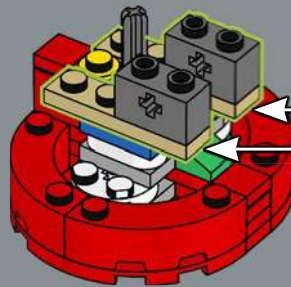
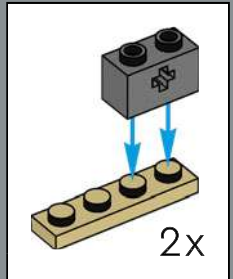



146

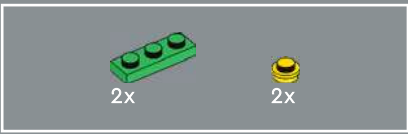
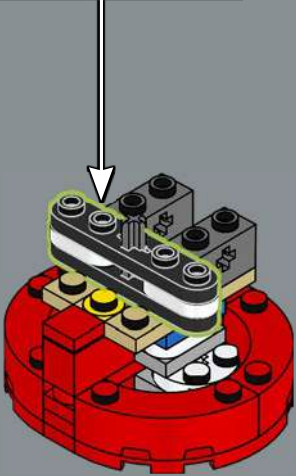
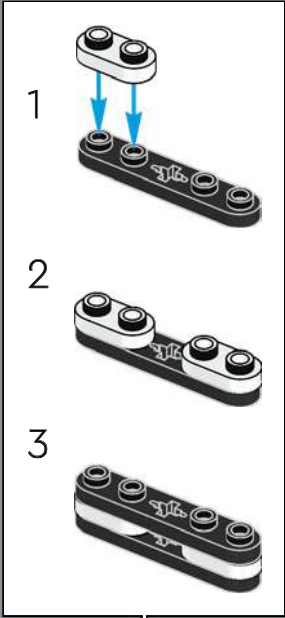

147

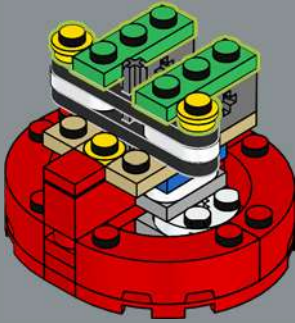

148

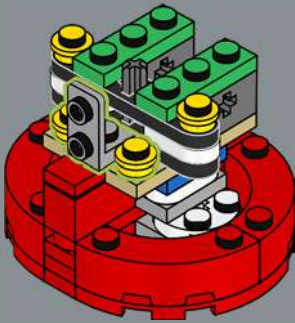

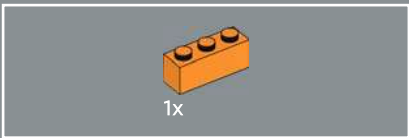

149

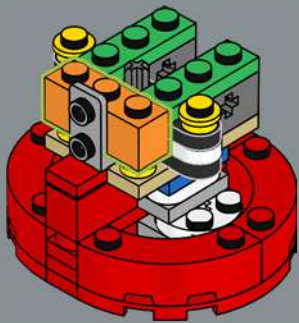

151

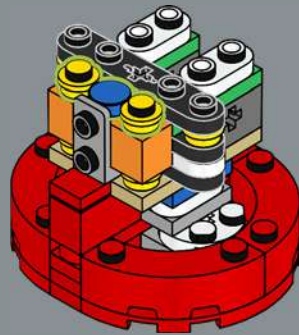

150

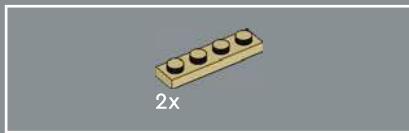
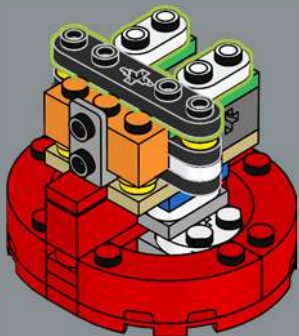

152

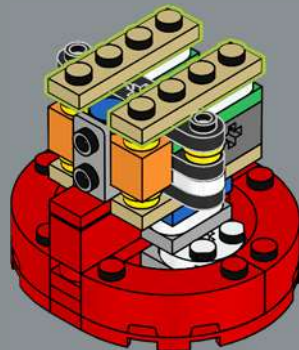



153

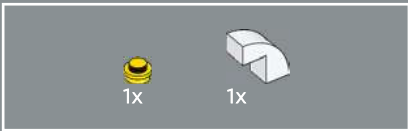
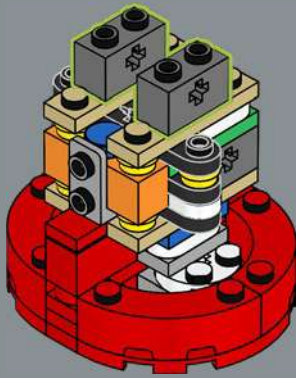

154

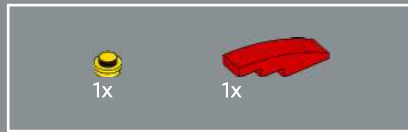
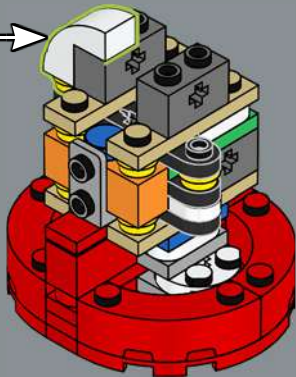
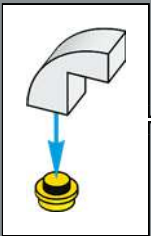

155

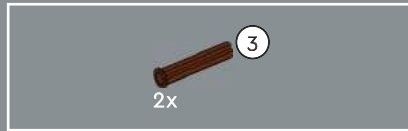
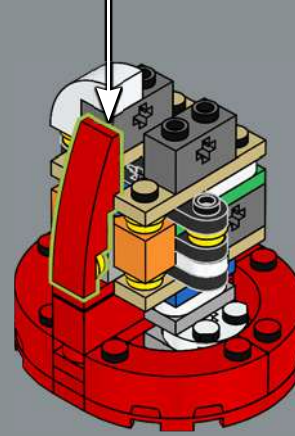
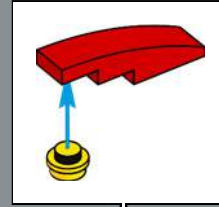

156

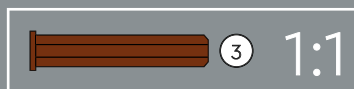
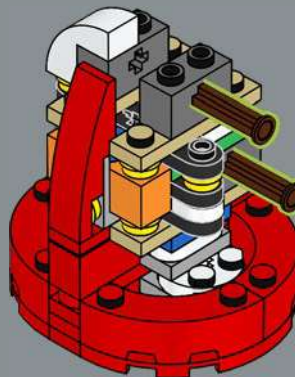

157

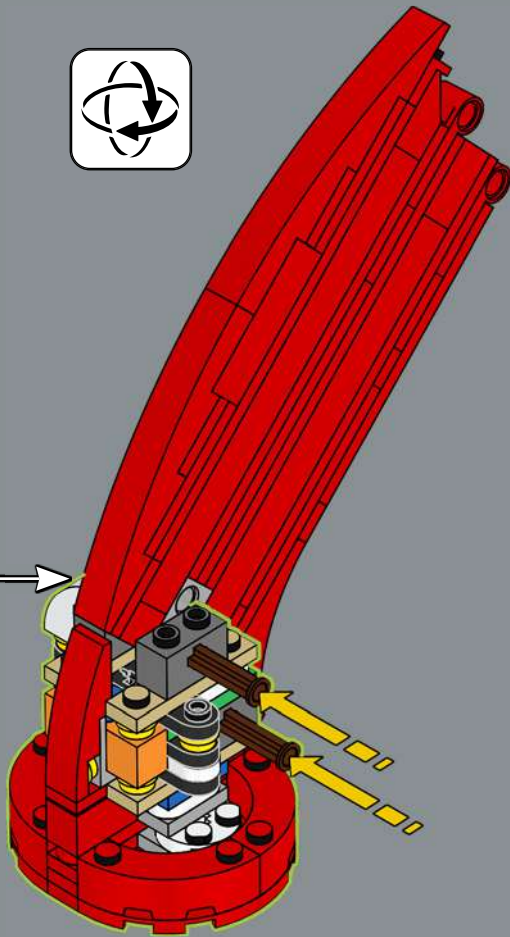

158

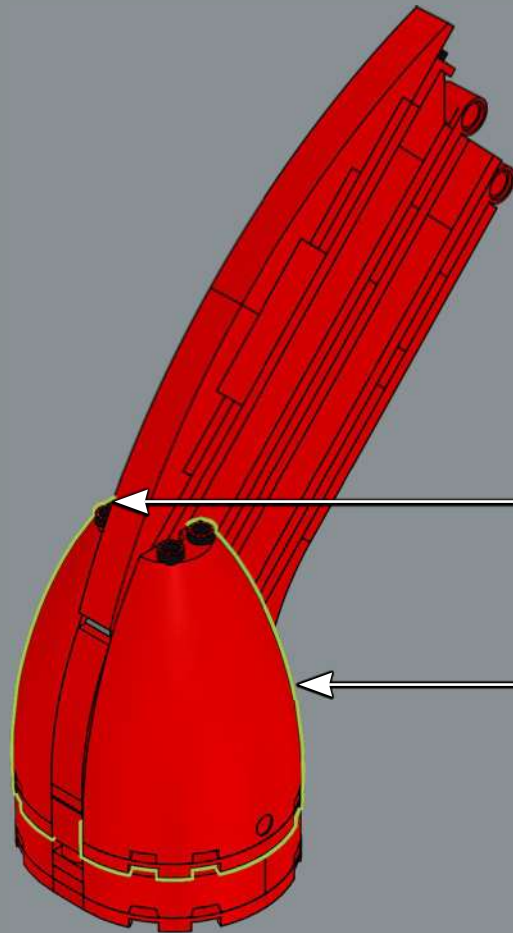
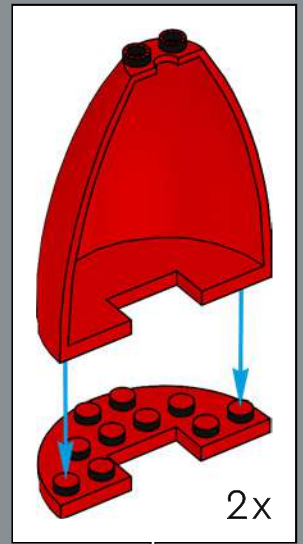
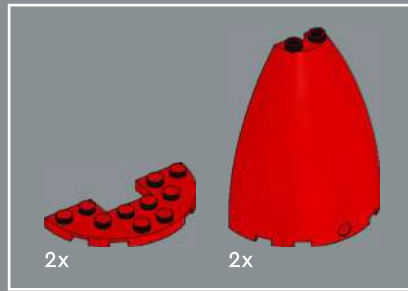

3x



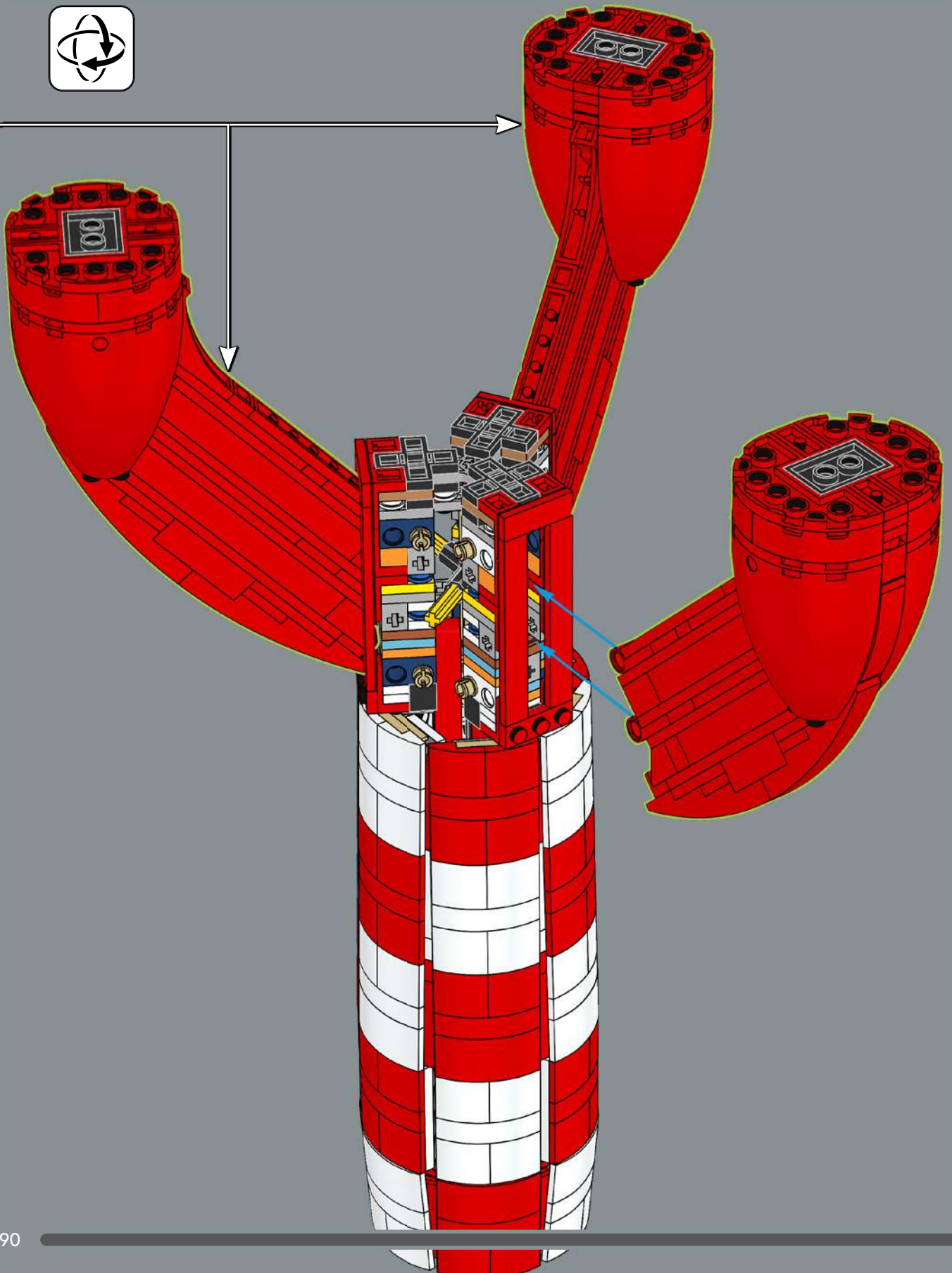

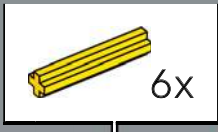
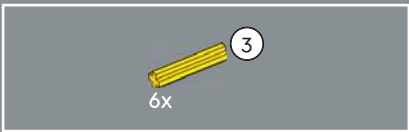

160

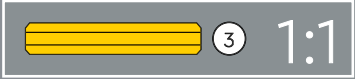
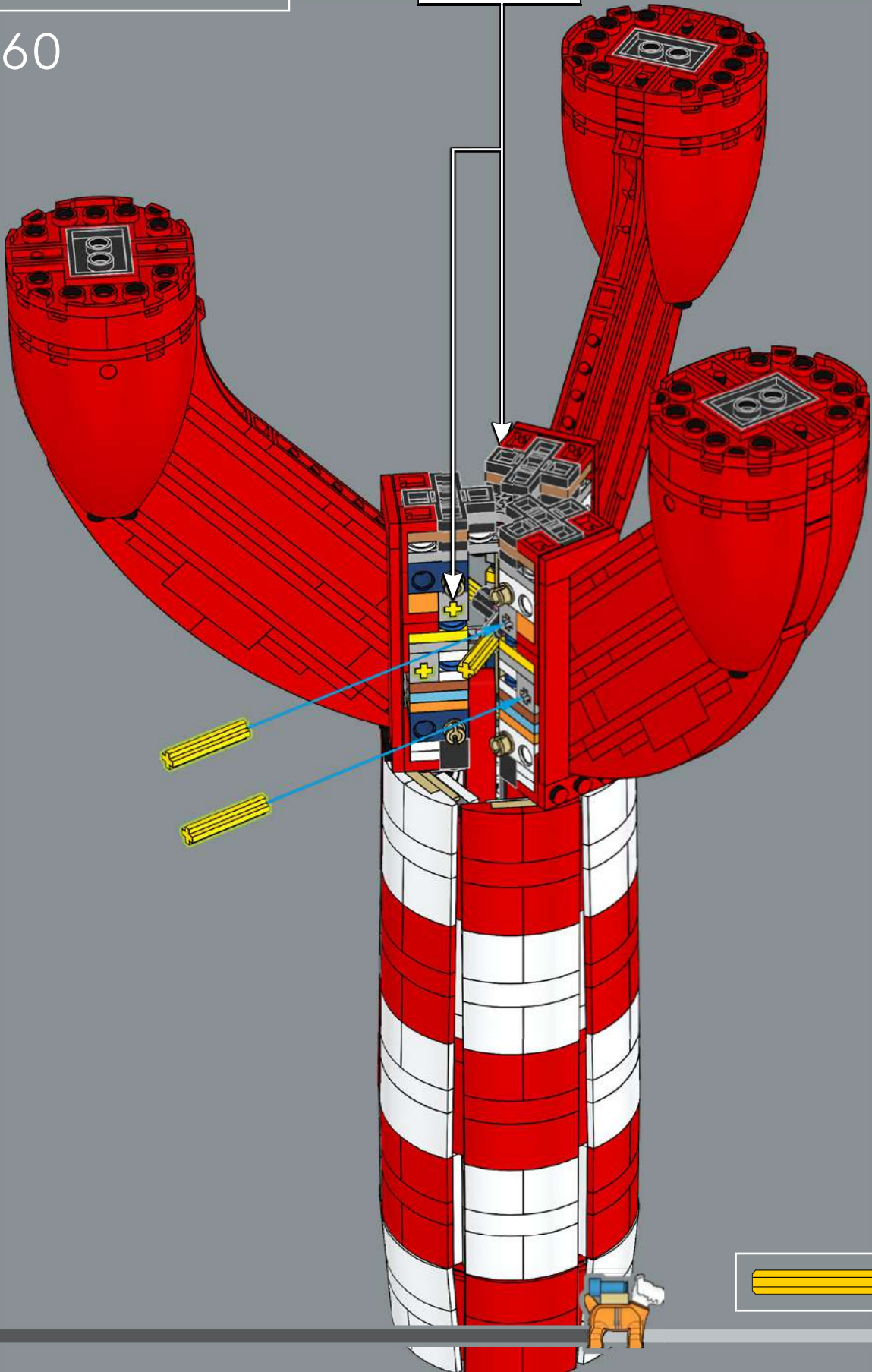



161

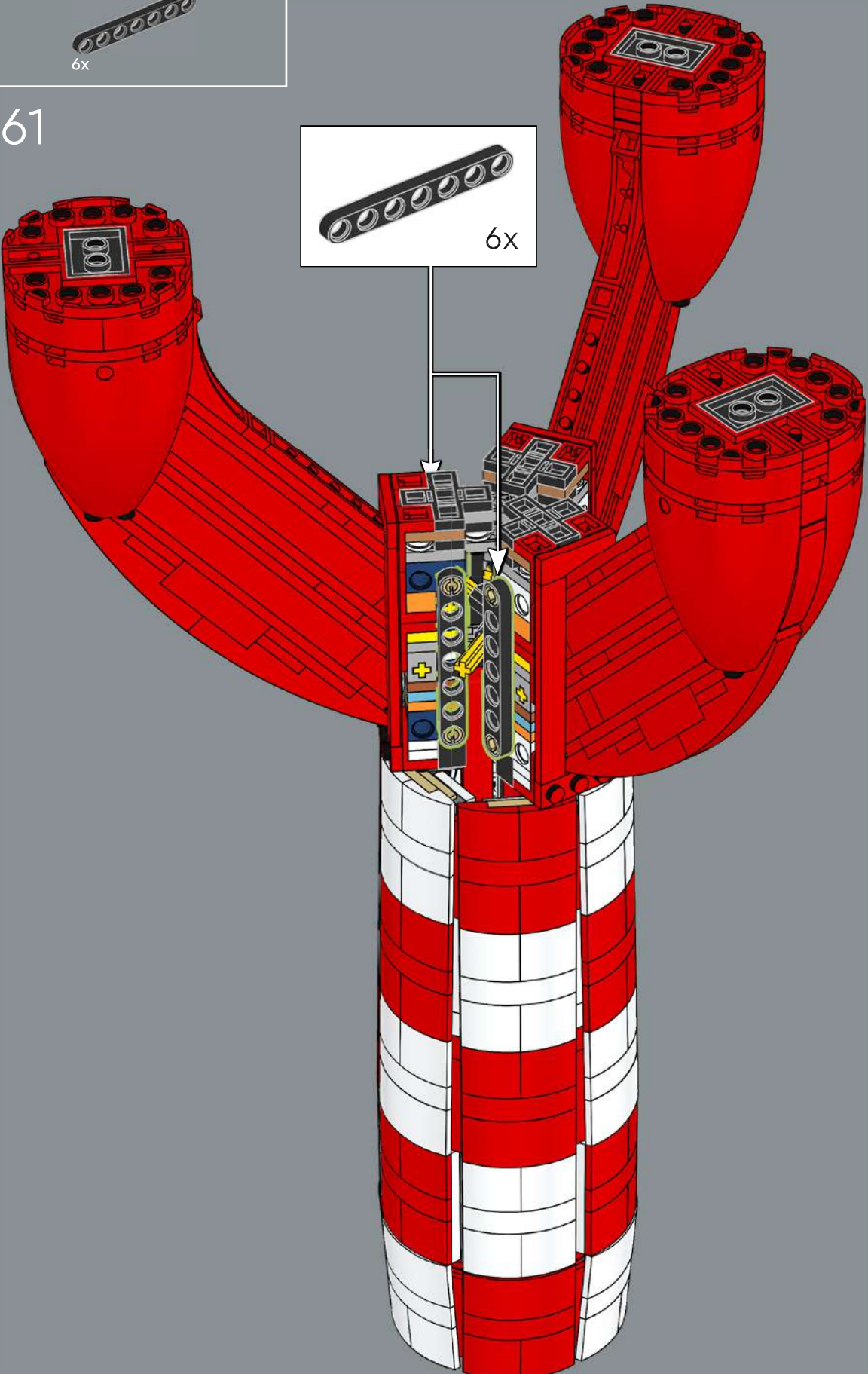
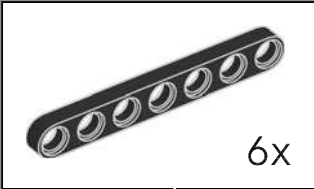

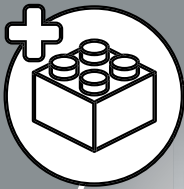

2x



3x

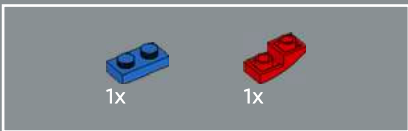

1x

1x

162

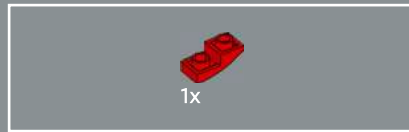
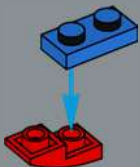

1x

163

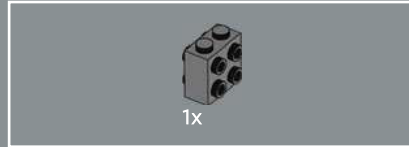
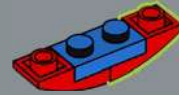

1x

164

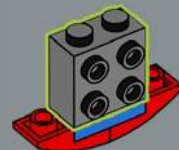



165

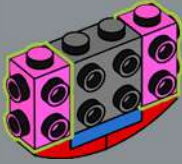

166

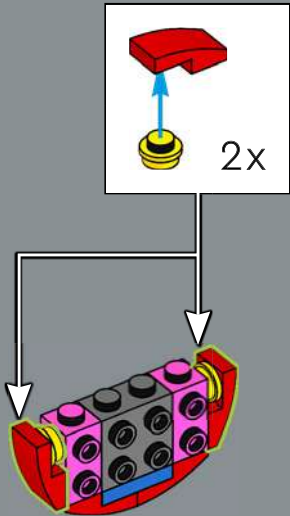

167

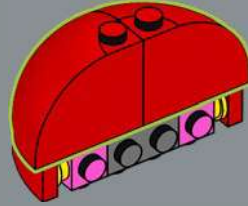

168

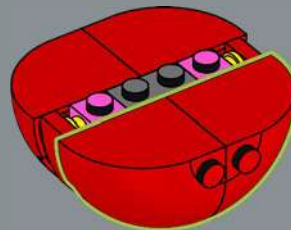

3x

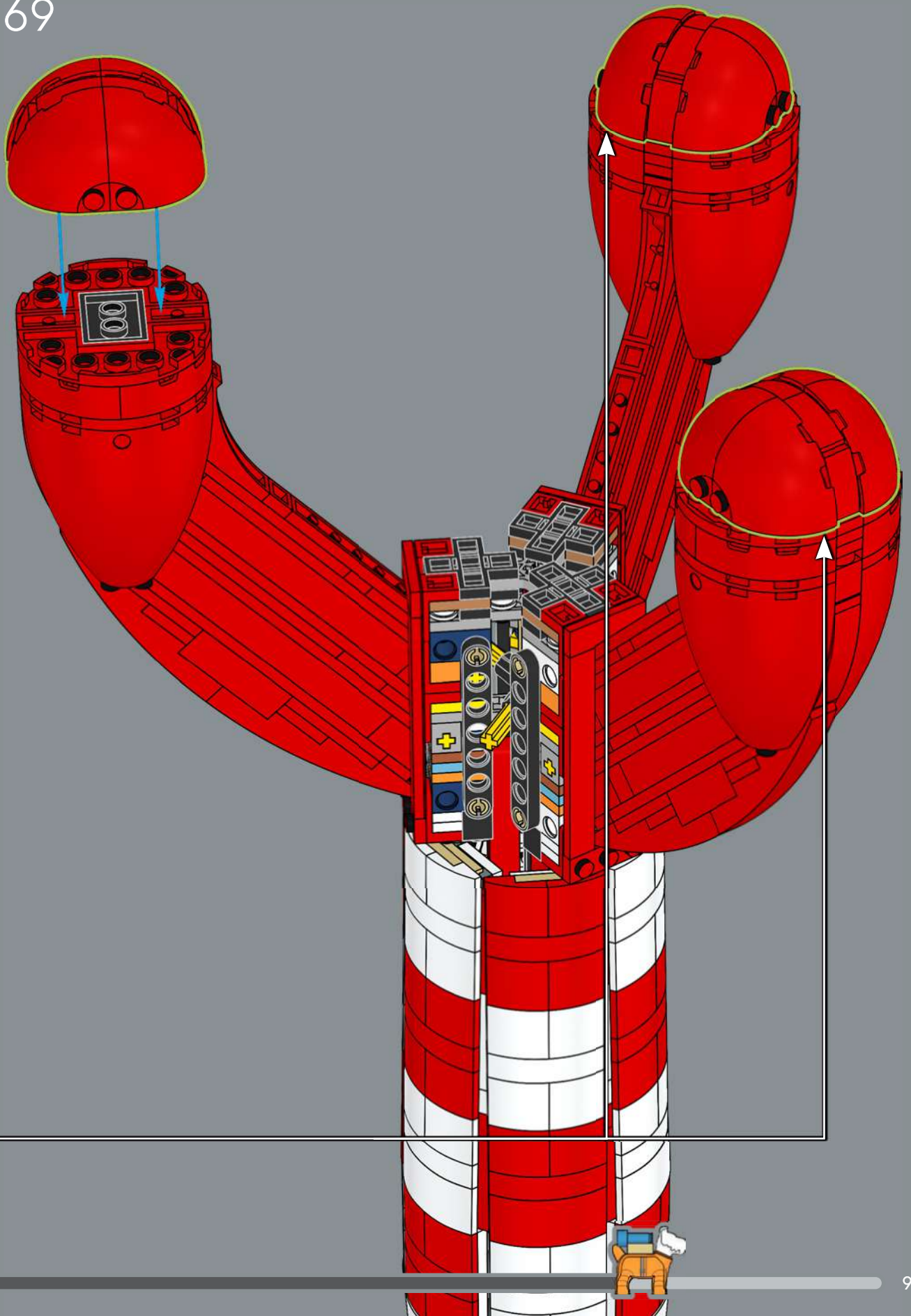

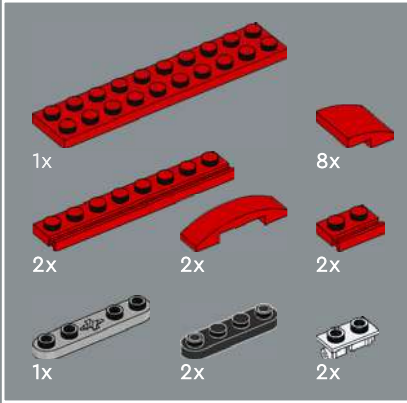

170

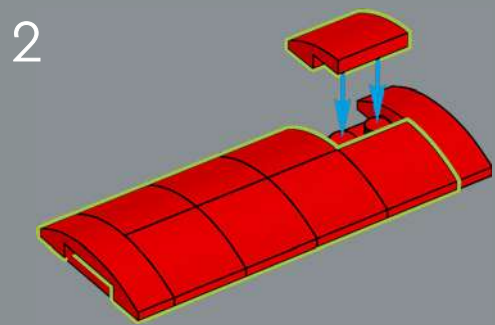
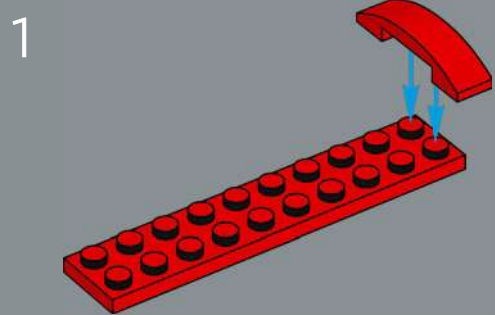

3

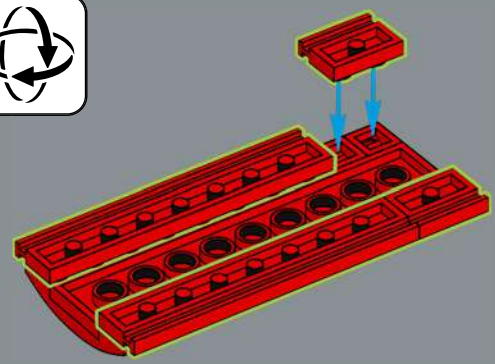

4

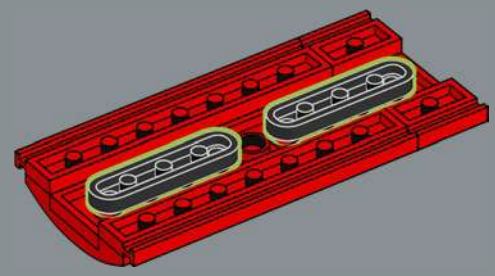

5

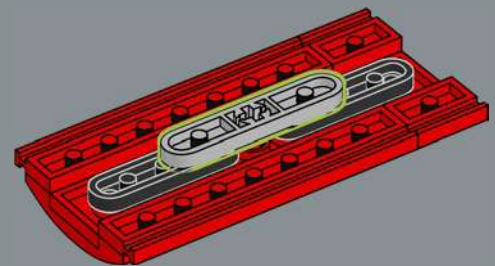

6

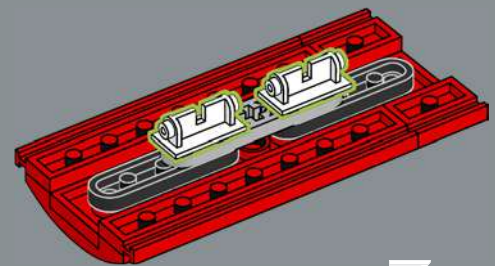

3x

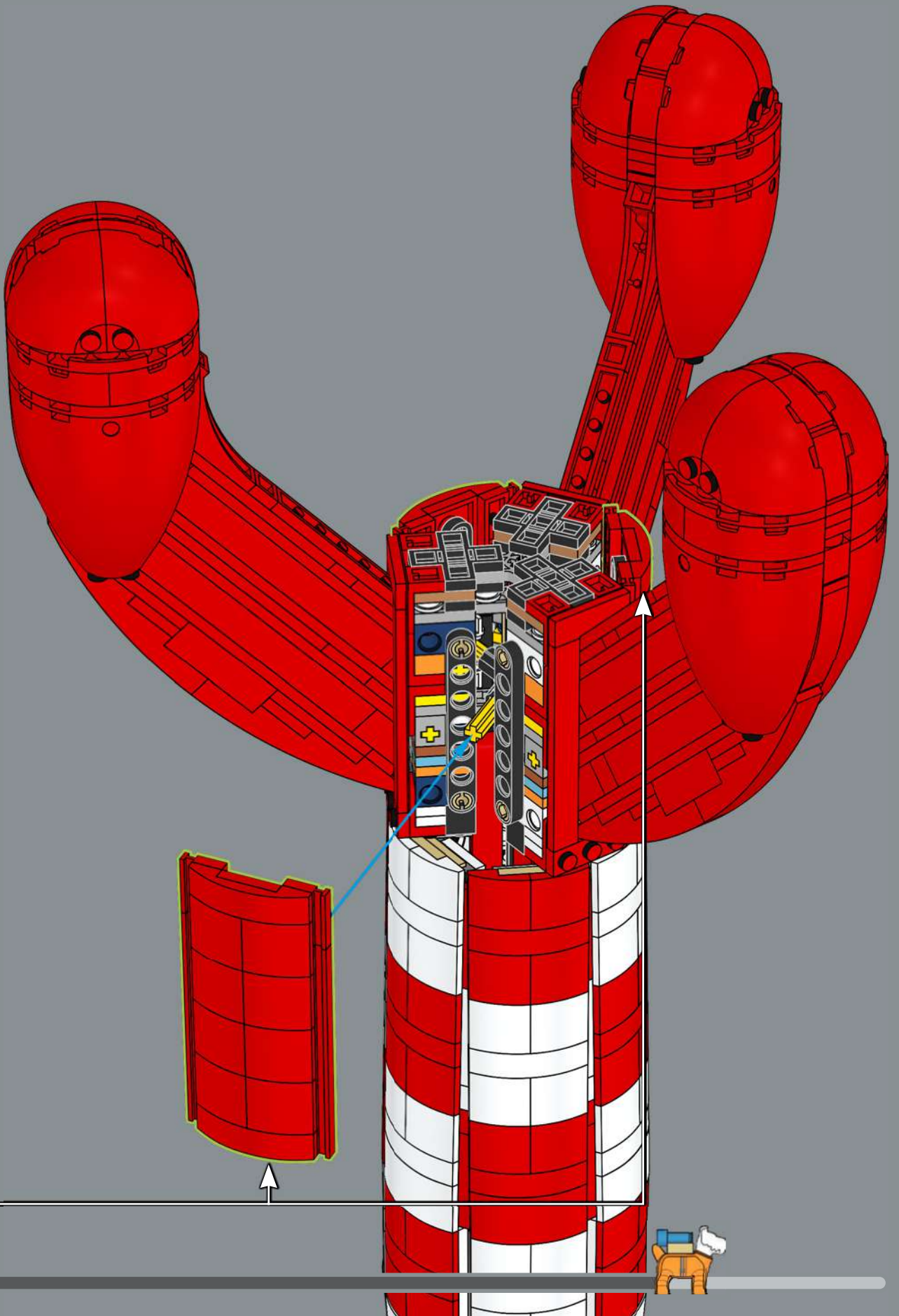



171

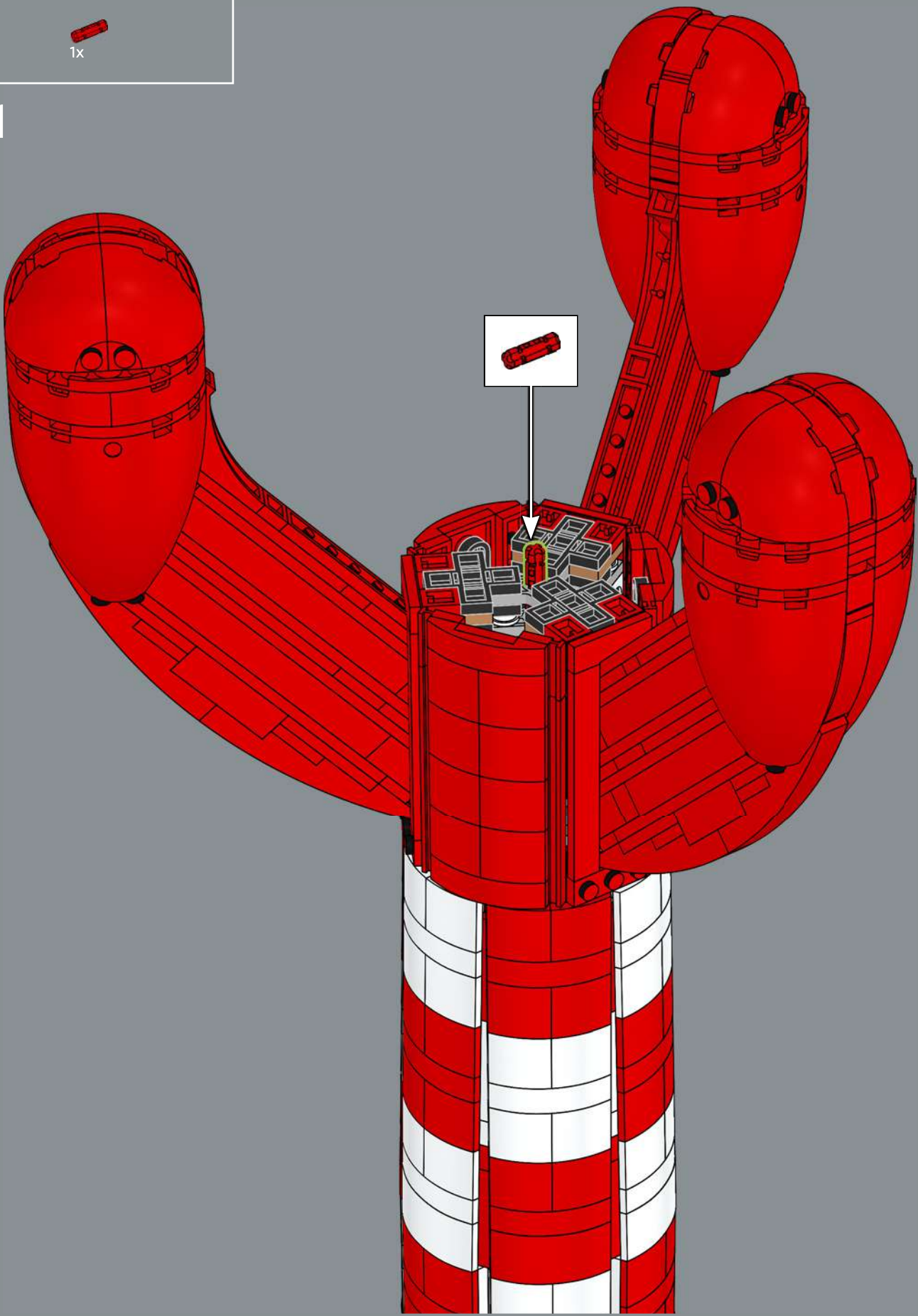

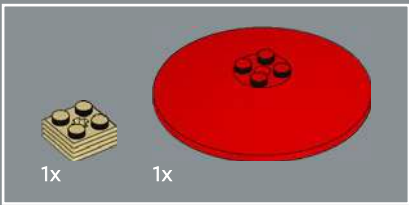

172

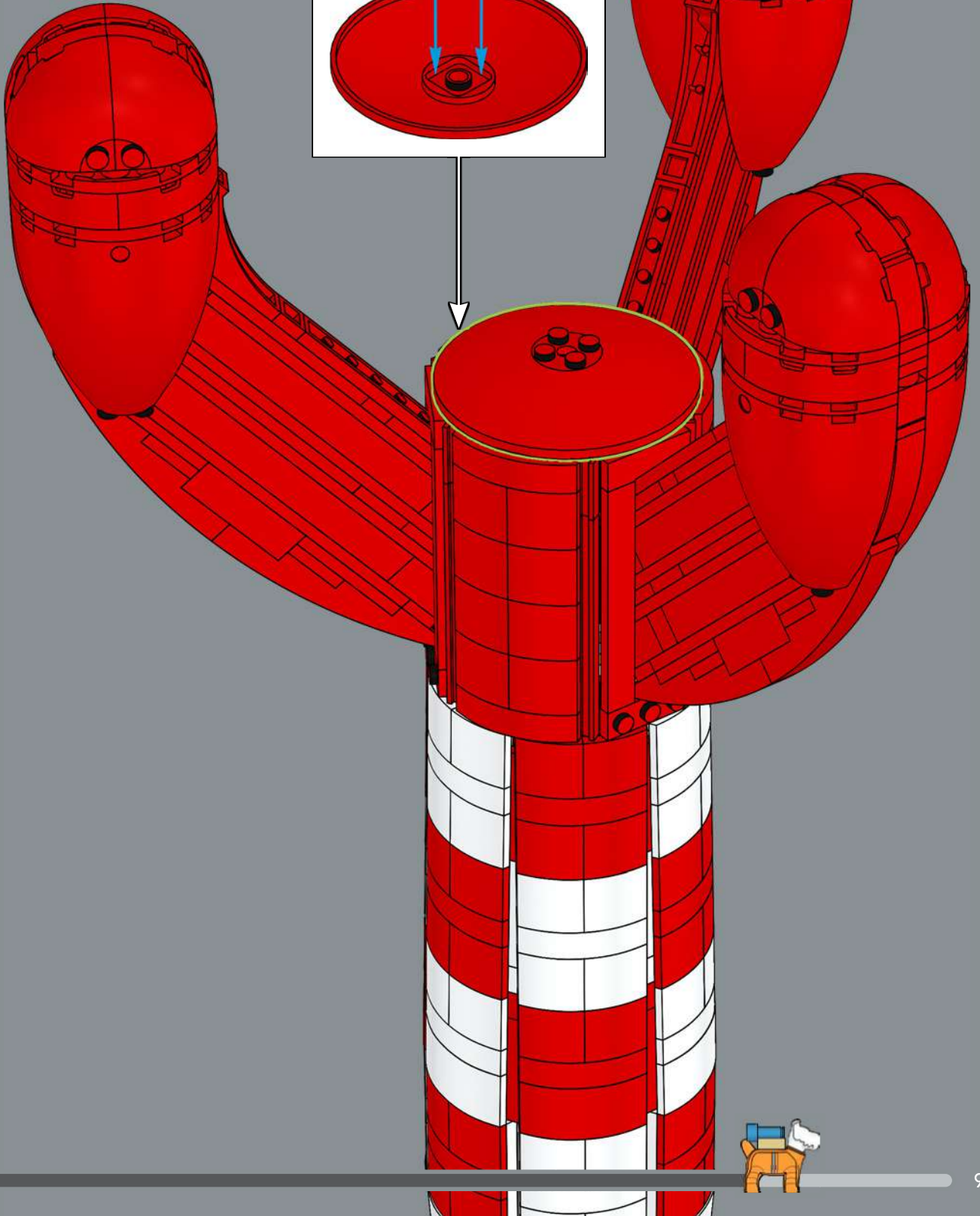
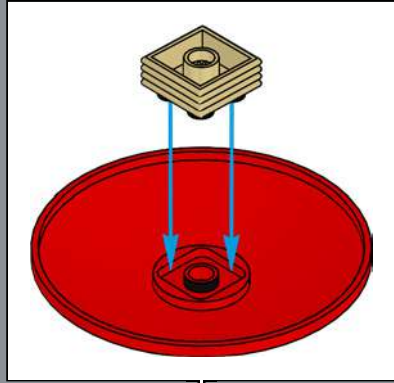



173

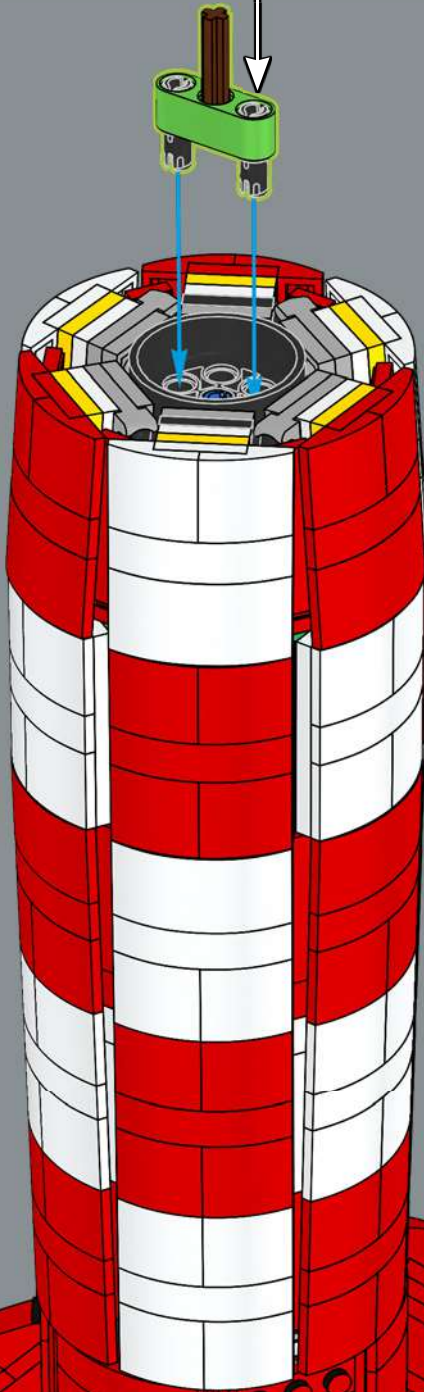
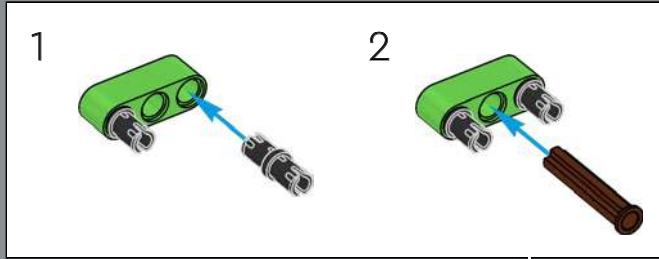

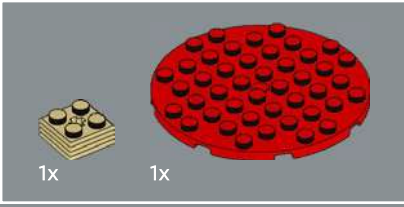

174

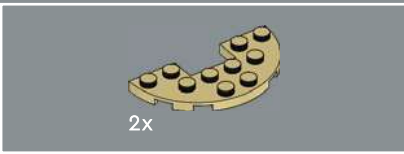
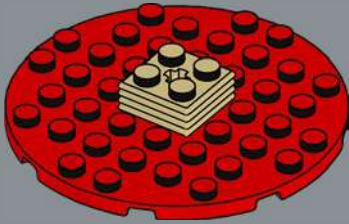

175

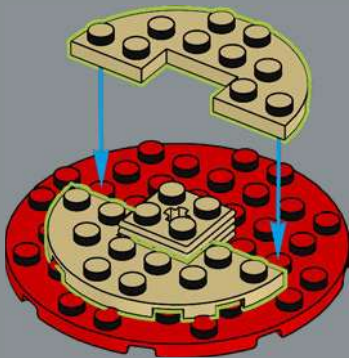

176

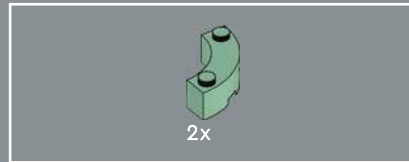
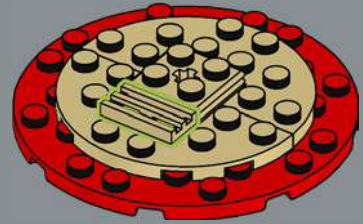

177

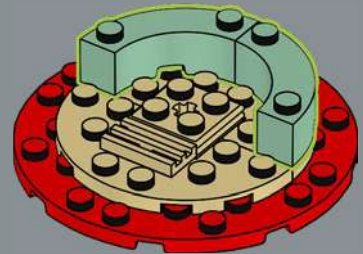



178

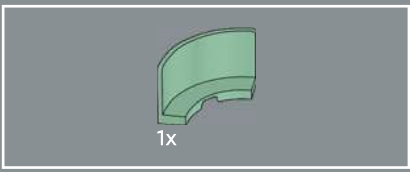
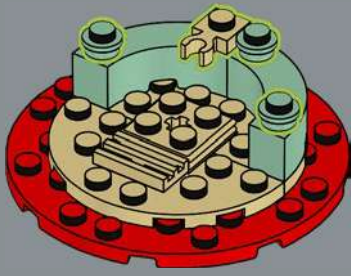

179

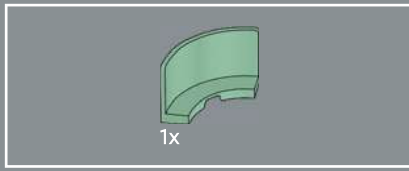
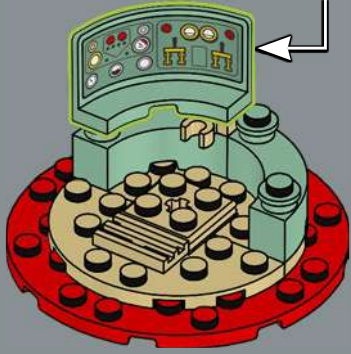
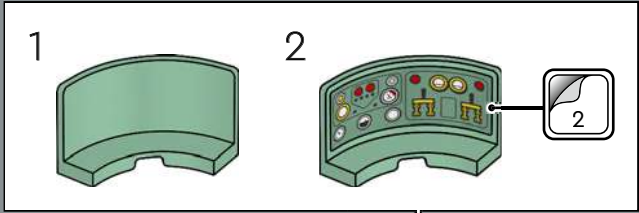

180

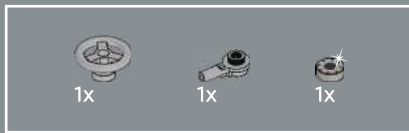
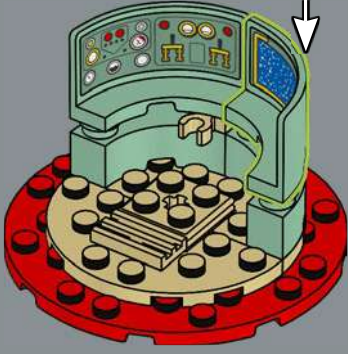
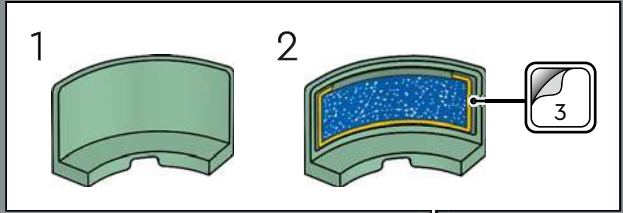

181

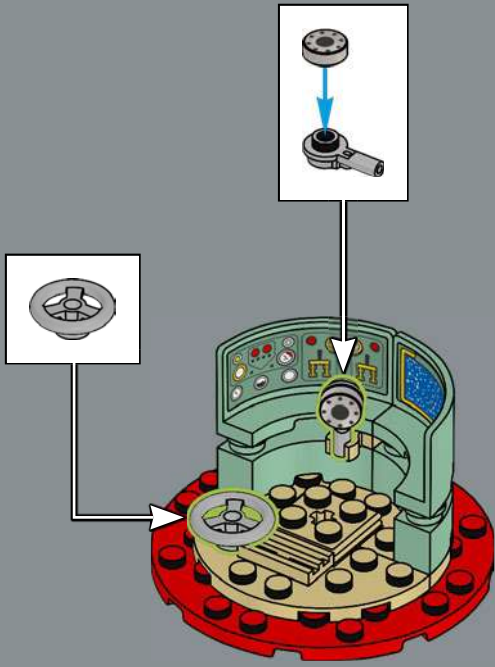

182

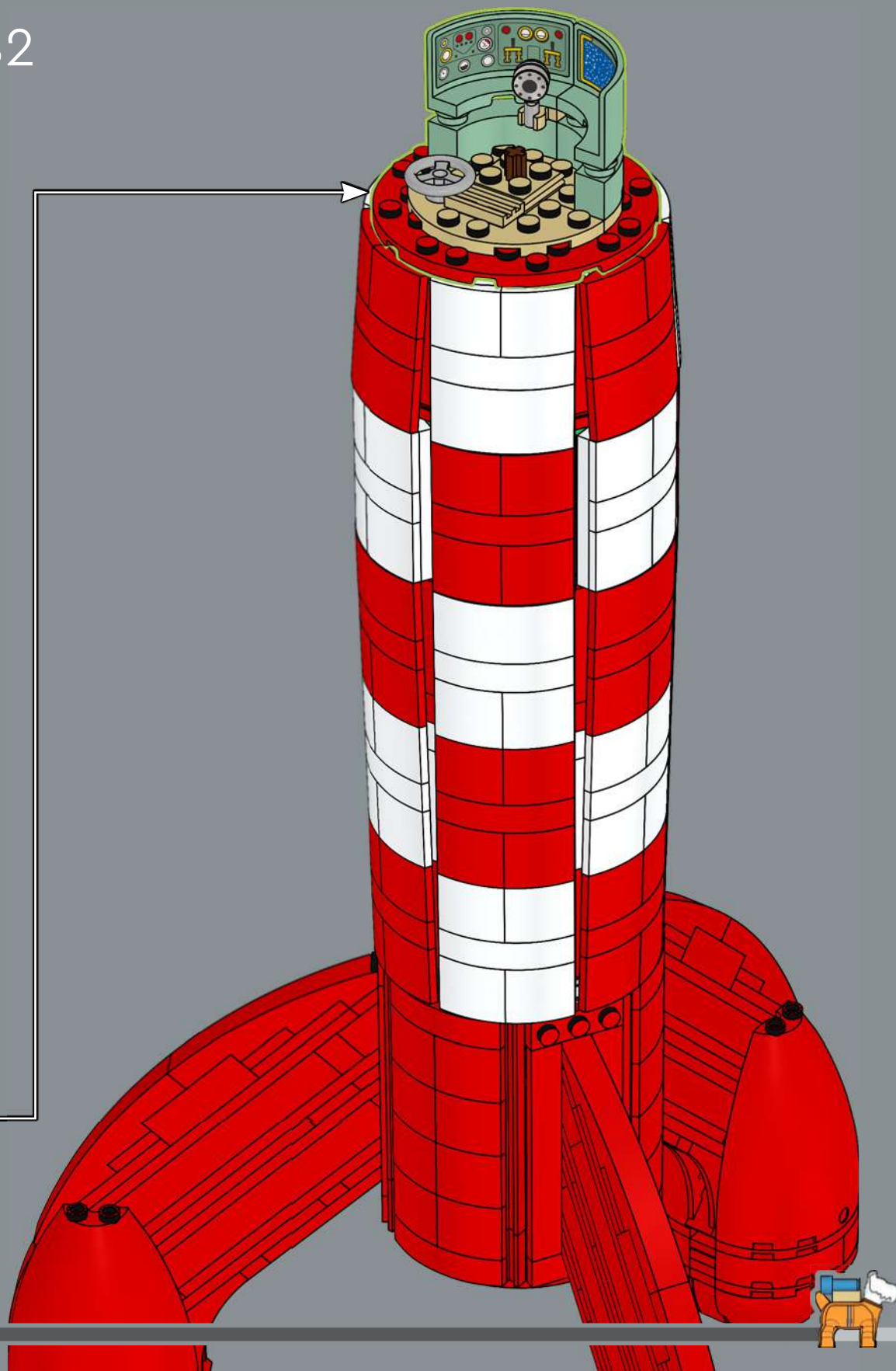

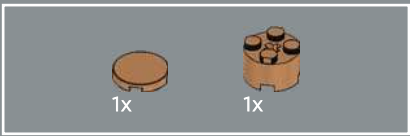

183

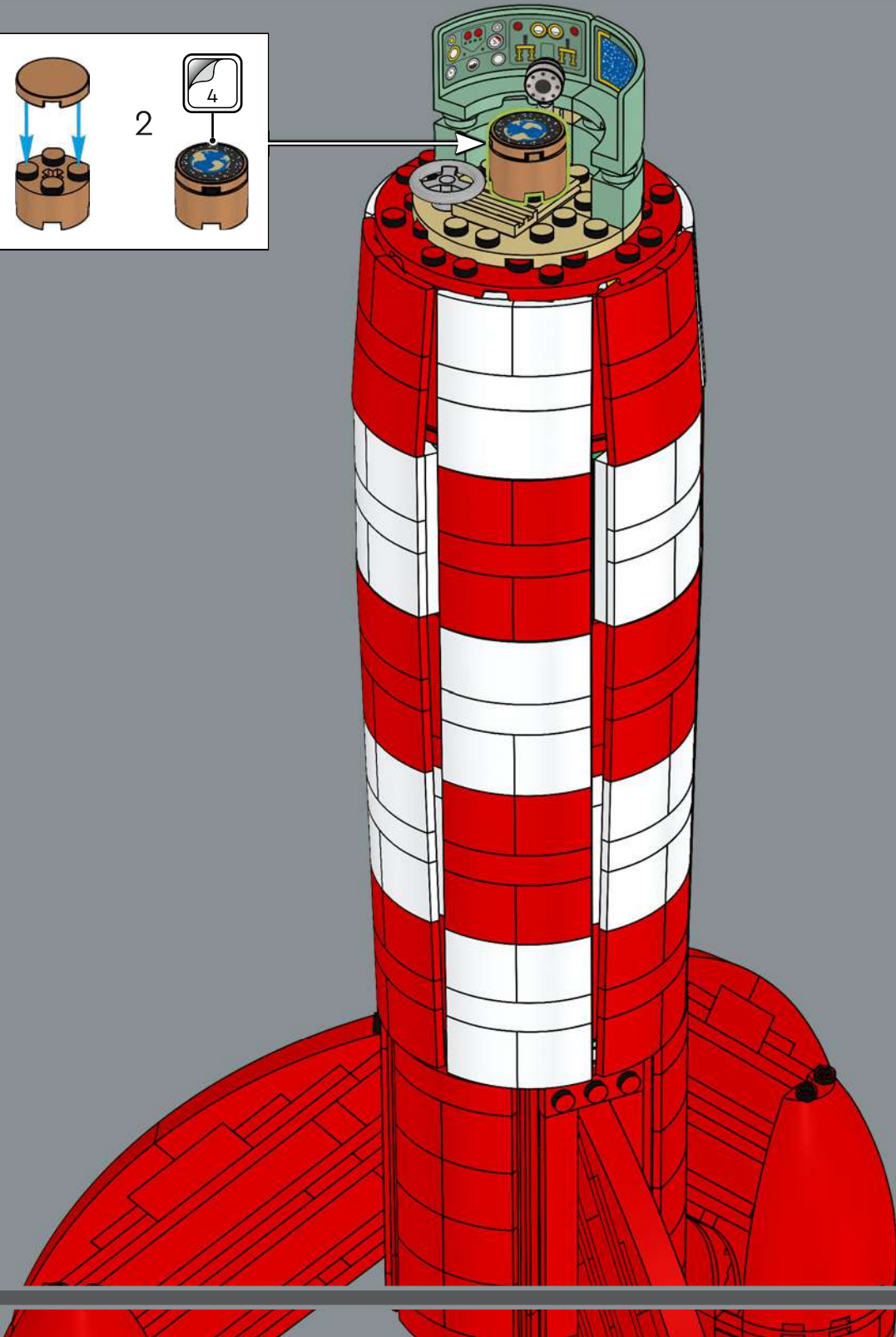
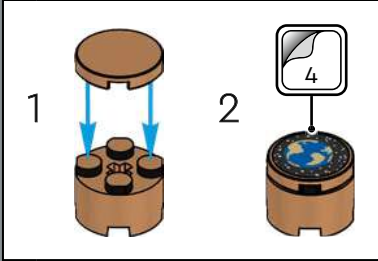



1x

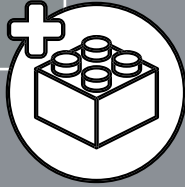

184

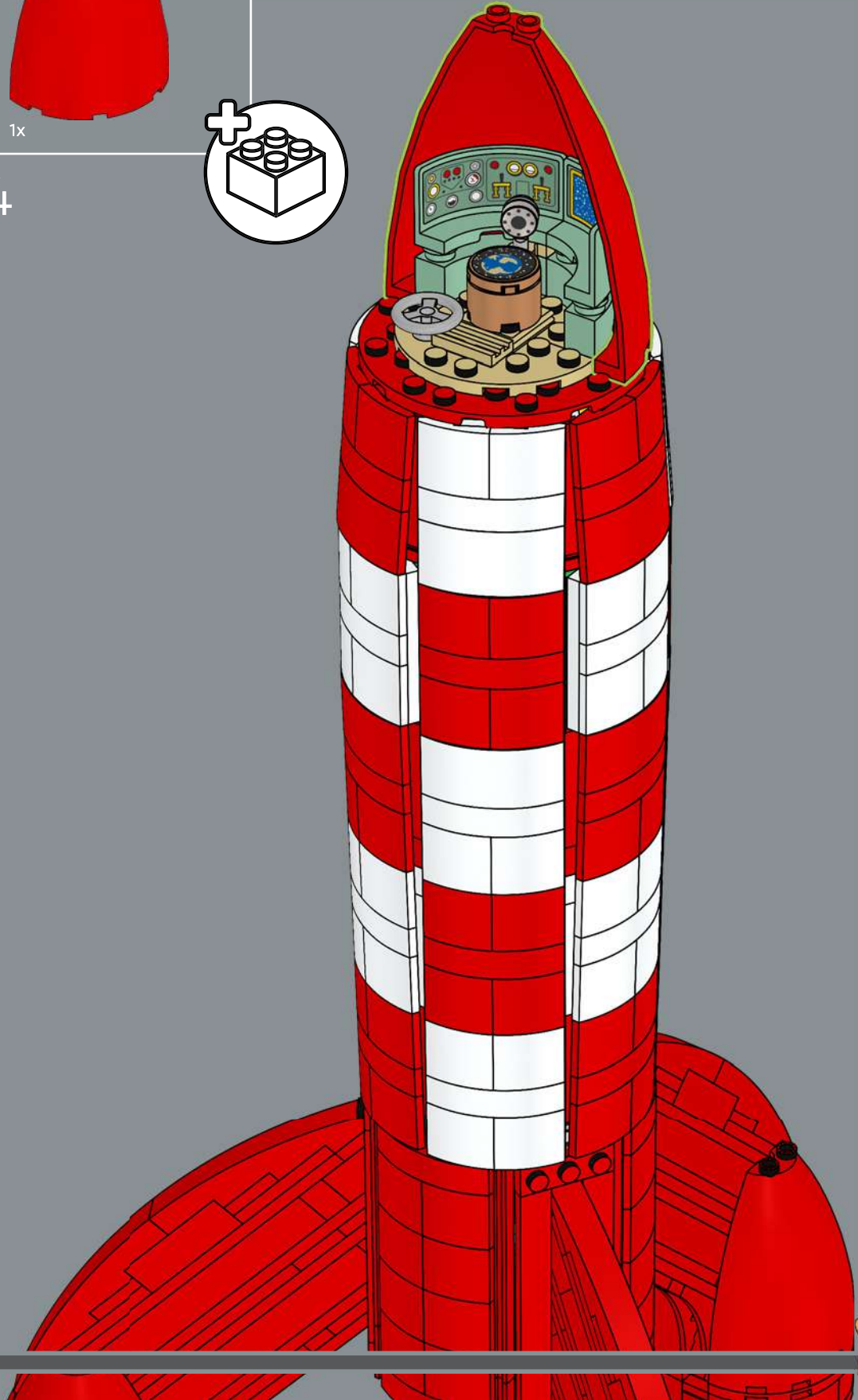



1x

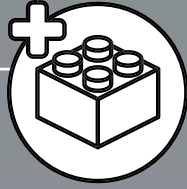

185

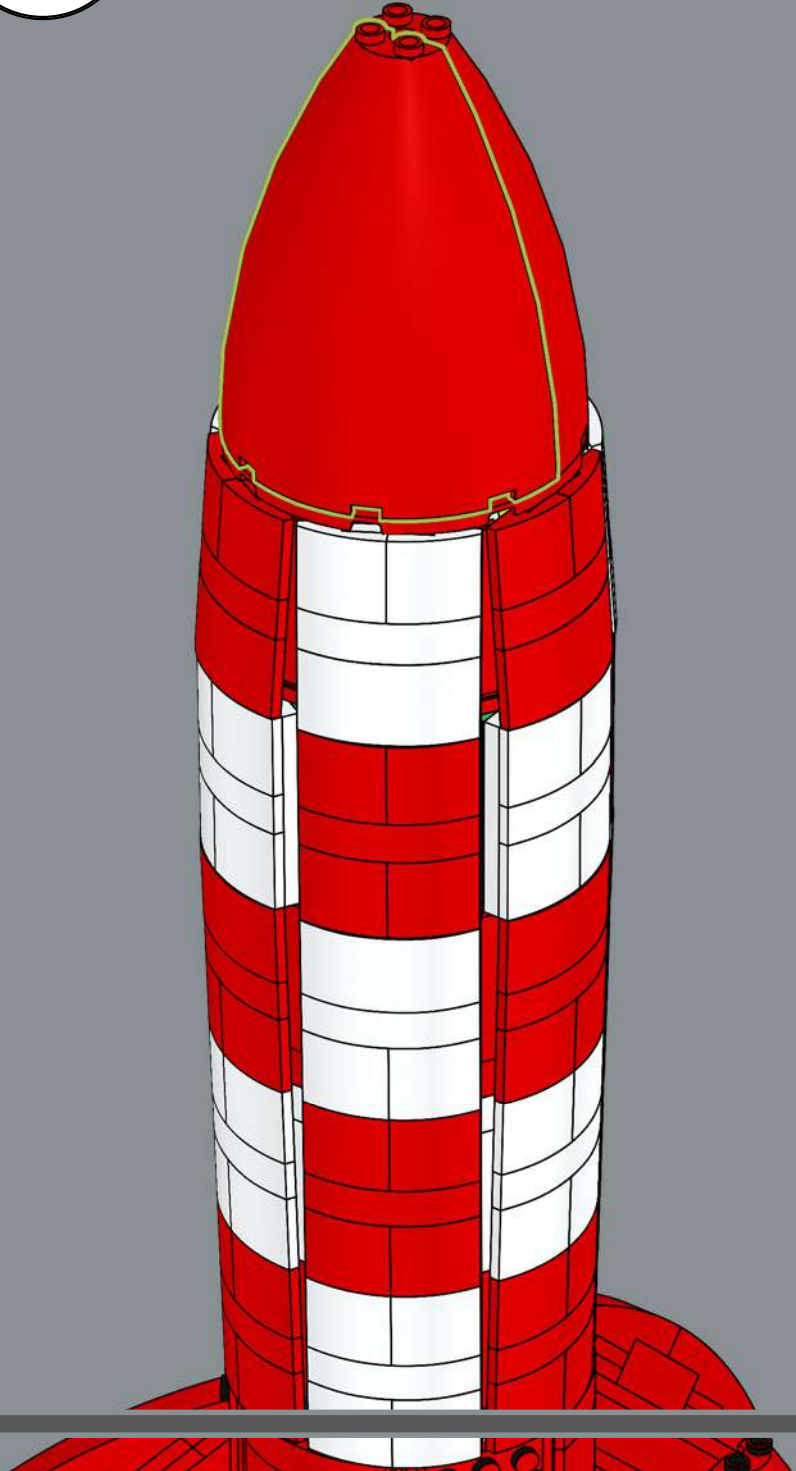

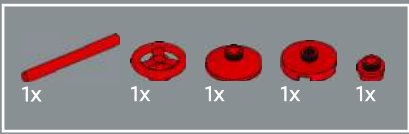

186

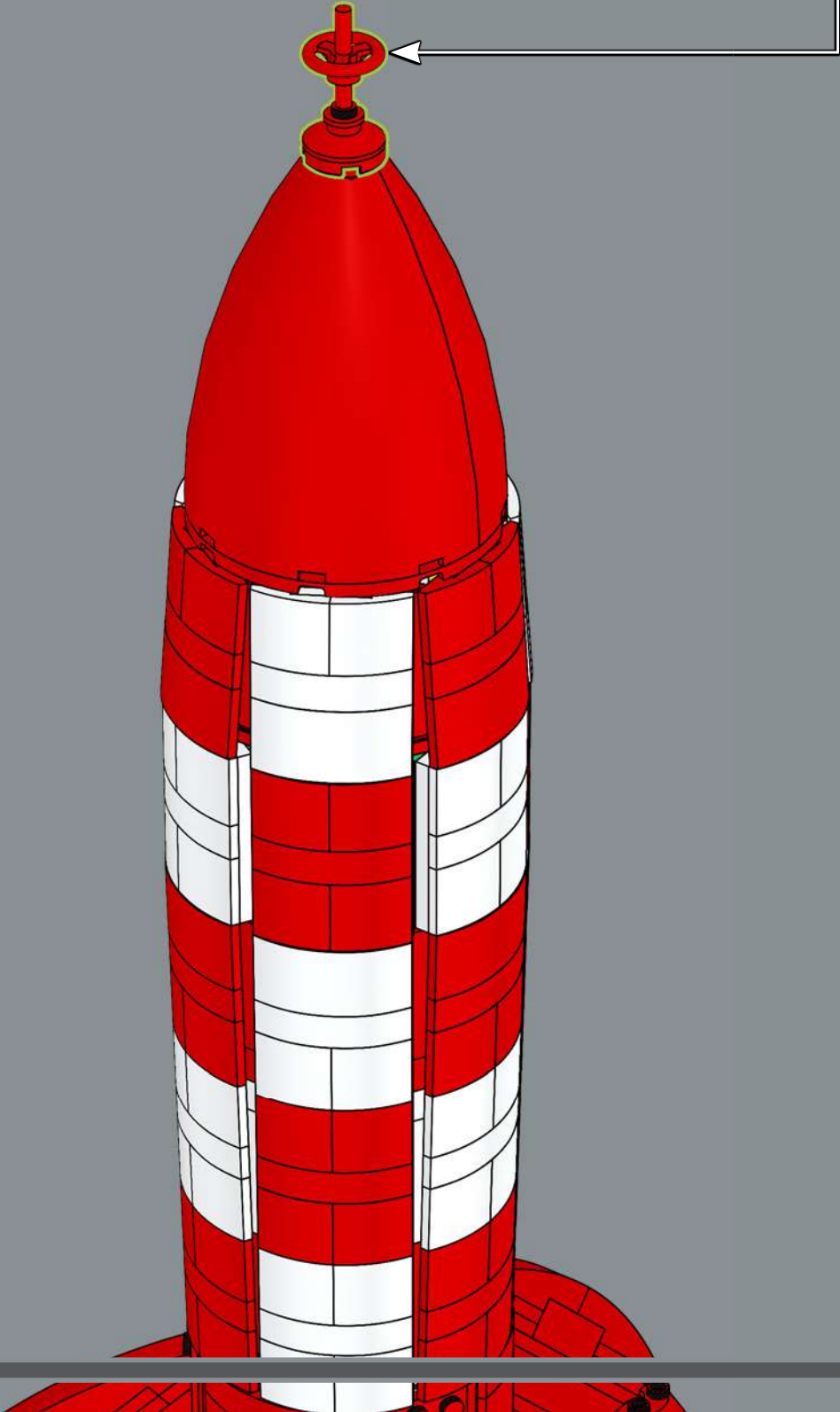
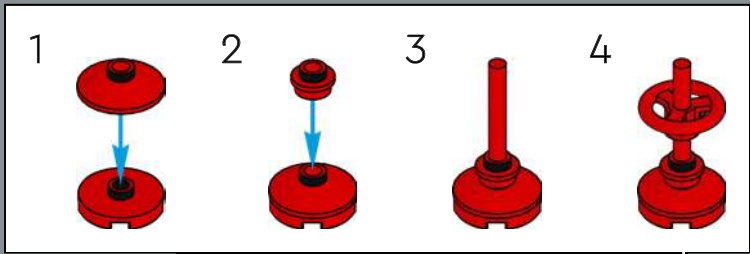

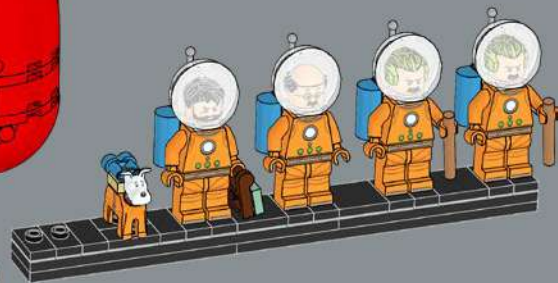
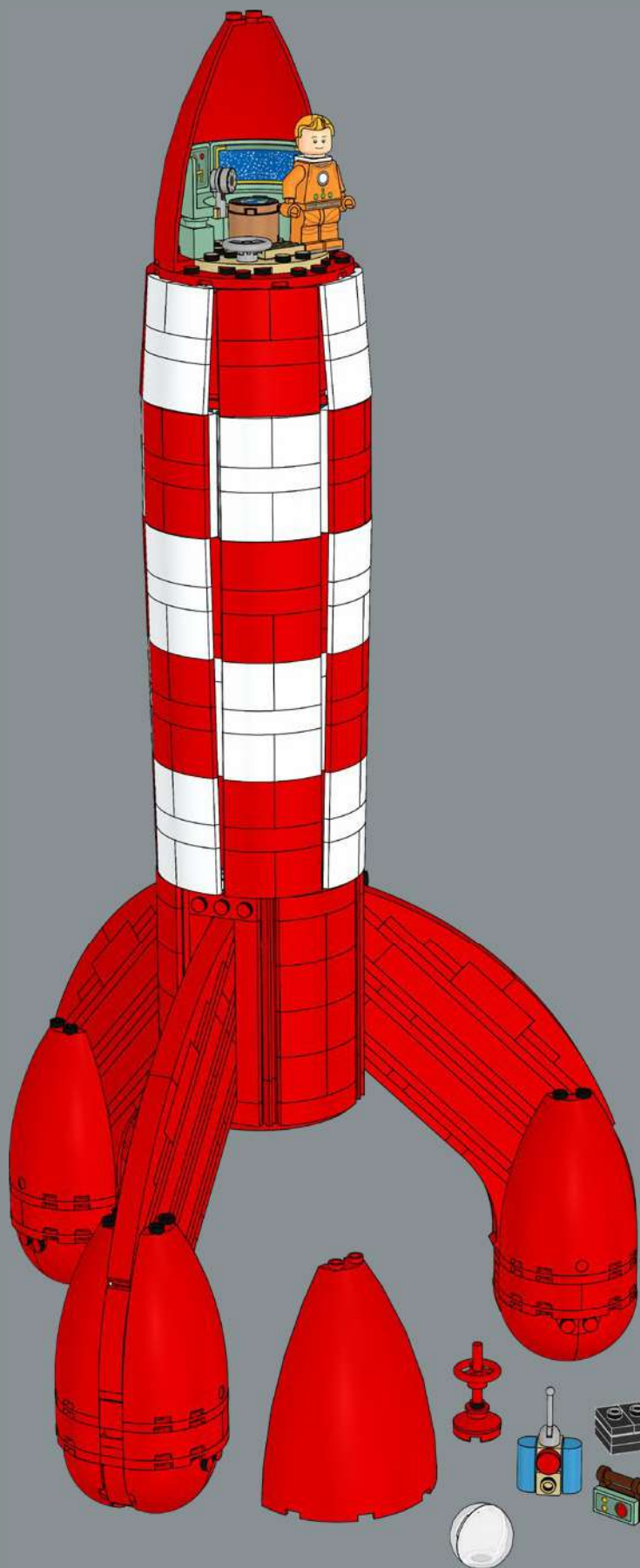

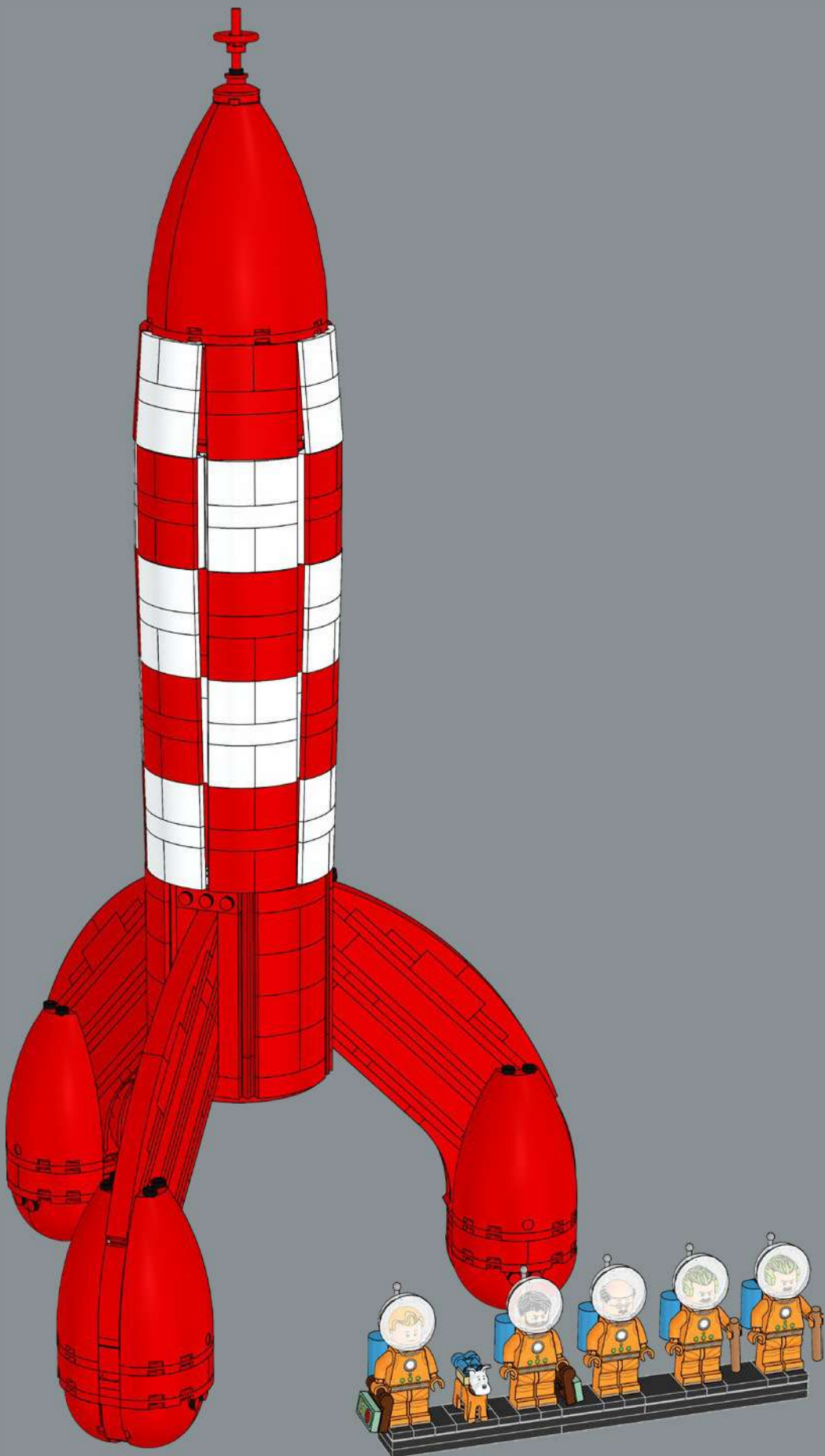

LEGO IDEAS

GATHER SUPPORT
HOL DIR UNTERSTÜTZUNG
RECUEILLENZ DES VOTES
CHIEDI DI ESSERE SUPPORTATO
CONSIGUE APOYOS
OBTÉM APOIO
爭取支持
ZDOBĄDŹ GŁOSY
ZÍSKEJTE PODPORU
ZÍSKAJTE PODPORU
SZEREZZ TÁMOGATÁST!
ЗБЕРІТЬ ПІДТРИМКУ
CERE SPRIJIN
ПОЛУЧЕТЕ ПОДКРЕПА
IEGŪSTI ATBALSTU
KOGU TOETUST
RINK PALAIKYMĄ

SHARE YOUR IDEA
TEILE DEINE IDEE
PARTAGEZ VOTRE IDÉE
CONDIVIDI LA TUA IDEA
COMPARTÉ TU IDEA
PARTILHA A TUA IDEIA
分享创意
PODZIEL SIĘ POMYSŁEM
SDÍLEJTE SVÉ NÁPADY
ZDIEĽAJTE SVOJE NÁPADY
OSZD MEG AZ ÖTLETED!
ПОДІЛІТЬСЯ СВОЮ ІДЕЄЮ
ÎMPĂRTĂȘEȘTE IDEEA TA
СПОДЕЛЕТЕ ИДЕИТЕ СИ
PARÁDI SAVU IDEJU
JAGA OMA IDEED
PASIDALINK SAVO IDĒJA

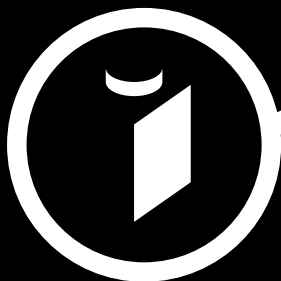
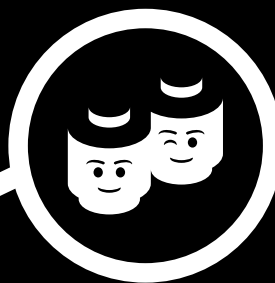

LEGO® REVIEW
LEGO® PRÜFUNG
EXAMEN PAR LEGO®
REVIEW LEGO®
REVISIÓN DE LEGO®
AVALIAÇÃO LEGO®
乐高®审核
OCENA LEGO®
POSOUZENÍ DESIGNÉRY LEGO®
POSÚDENÉ DIZAJNÉRMÍ LEGO®
LEGO® VÉLEMÉNYEZÉS
ОГЛЯД LEGO®
VERIFICARE LEGO®
ΠΡΕΓΛΕΔ ΗΑ LEGO®
LEGO® RECENZIJA
LEGO® ARVUSTUS
LEGO® APŽVALGA

NEW LEGO® PRODUCT
NEUES LEGO® PRODUKT
NOUVEAU PRODUIT LEGO®
NUOVO PRODOTTO LEGO®
NUEVO PRODUCTO LEGO®
NOVO PRODUTO LEGO®
全新乐高®产品
NOWY PRODUKT LEGO®
NOVÁ STAVEBNICE LEGO®
NOVÁ STAVEBNICA LEGO®
ÚJ LEGO® TERMÉK
НОВИЙ ПРОДУКТ LEGO®
PRODUS LEGO® NOU
НОВ ПРОДУКТ LEGO®
JAUNS LEGO® PRODUKTS
UUS LEGO® TOODE
NAUJAS LEGO® PRODUKTAS

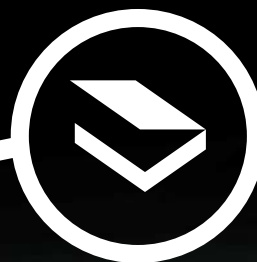

ideas.LEGO.com

- 9x 6388018
- 15x 614101
- 6x 307001
- 5x 6277181
- 6x 6212049
- 18x 6210272
- 6x 393801
- 15x 302301
- 3x 6548968
- 6x 6172927
- 12x 403201
- 6x 3200001
- 12x 6361170
- 48x 6047220
- 6x 6223491
- 12x 362301
- 6x 302201
- 15x 6023806
- 6x 243101
- 6x 6554416
- 3x 302001
- 24x 6350399
- 3x 4249021
- 6x 6053026
- 5x 6365720
- 1x 4159553
- 5x 4125253
- 5x 6609636
- 1x 6352222
- 5x 6262188
- 12x 6013938
- 1x 4124456
- 2x 6330903
- 6x 4160483
- 12x 4113233
- 2x 6099893
- 6x 4114324
- 6x 6036487
- 5

- 5x 6284574
- 9x 6378120
- 6x 6249907
- 1x 6223427
- 18x 307021
- 6x 302421
- 3x 6372478
- 12x 6345637
- 3x 300521
- 12x 6435047
- 1x 6527648
- 1x 6132541
- 6x 6029946
- 1x 4585146
- 3x 4142865
- 27x 302321
- 6x 6186398
- 3x 366521
- 6x 300421
- 72x 6105976
- 9x 6433069
- 6x 6347789
- 6x 4612575
- 3x 4533742
- 3x 362321
- 12x 6334053
- 1x 6296954
- 1x 6129995
- 3x 6583512
- 3x 6547141
- 21x 4633914
- 6x 371021
- 18x 243121
- 6x 6592314
- 3x 302021
- 3x 301021
- 3x 4142132
- 4
- 5

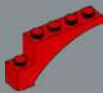

3x
6594986



12x
6295298



3x
366621



6x
6594751

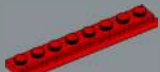

6x
6078594

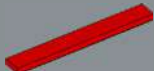

6x
416221



9x
346021



6x
6594753



2x
6595787

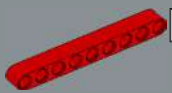

9

3x
4645733



1x
6603363

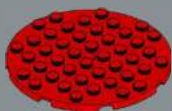

1x
6594752

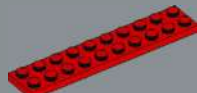

3x
383221

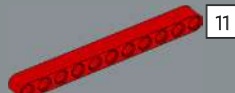

11

3x
4562805



12x
4514843

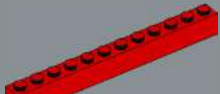

6x
611221



3x
6284575



3x
6584954



6x
6537695



12x
614123



19x
4206482



9x
302323



6x
6073890

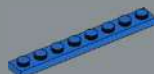

6x
346023



33x
614124



15x
302324



3

9x
6130007



6x
4501232



5

1x
6130008



6x
371024



1x
6389951



2x
6332148



1x
4526110



3x
6299338



17x
6279875



12x
6210270



12x
6092585



2x
306926



3x
6089119



6x
6097283



3x
306826



3x
6572774



1x
6460708



6x
6428167



2x
6416838



3x
302126



9x
6280168



1x
6438426



6x
6271573

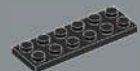

6x
379526



8

1x
370726



2x
303426



10

1x
373726



2x
244526

6x
4569058

6x
6541878

6x
6510079

1x
6374076

3x
6047426

21x
302328

6x
6347288

6x
4521931

6x
4107758

1x
6573947

3x
6359717

10x
6414564

6x
6442359



9x
4177932



5x
6593094



1x
6593089



3x
4118787



5x
6607486

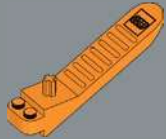

1x
6240515



6x
6539419



6x
6574771



5

3x
6420960



3x
6403175



2x
4616578



2x
6599347



2x
6599346



2x
6607967



1x
6595785



2x
6236915



3

7x
6135494



8x
6441316



5x
6267587



3x
6345639



18x
6336539



1x
6227897



3x
4211350



1x
6092956



3x
4211862



3x
4211541



3x
6540763



3x
6321747



4x
6043639



6x
4211397



12x
6421522



6x
6347992



3x
6549304



3x
6307999



6x
6372029



6x
6372029



6x
4211462



3x
4611705



3x
6395635



3x
6395635



12x
6178919



3x
6514456



6x
6284702



3x
6083620



6x
6039482



1x
6443852



6x
6574782



3x
6573660



1x
6593099



1x
6593098



1x
6593097



1x
6593096



1x
6593095



1x
6593090



1x
6368592



1x
6454167



2x
6600809



3x
6336665



1x
6551965



1x
6603200



10x
6601287



9x
6097419



YOU COULD WIN



YOU COULD WIN

Your feedback will help shape the future development of this product series.

Visit:

DU KÖNNTEST GEWINNEN

Dein Feedback trägt zur Weiterentwicklung dieser Produktreihe bei.

Geh auf:

VOUS POURRIEZ GAGNER

Vos commentaires nous aideront à concevoir les futurs produits de cette gamme.

Visitez :

POTRESTI VINCERE TU

La tua opinione ci aiuterà a migliorare la creazione futura di questa linea di prodotti.

Visita:

PUEDES GANAR

Tu opinión contribuirá al futuro de esta serie de productos.

Visita:

轻松获奖

您的反馈将有助于我们在今后改进本产品系列。

请访问:

LEGO.com/productfeedback

You also have the chance to win a LEGO® set.

Terms and conditions apply.*

Außerdem hast du die Chance, ein LEGO® Set zu gewinnen.

Es gelten die Teilnahmebedingungen.*

Vous pourriez également gagner un ensemble LEGO®.

Des conditions s'appliquent.*

Hai anche la possibilità di vincere un set LEGO®.

Termini e condizioni sono applicabili.*

También tienes la oportunidad de ganar un set LEGO®.

Aplican términos y condiciones.*

您还有机会赢取乐高®套装。

条款和条件适用。*

*LEGO.com/productfeedback-terms



In partnership with the Hergé Museum
In Partnerschaft mit dem Hergé-Museum
En partenariat avec le Musée Hergé
In collaborazione con l'Hergé Museum
En colaboración con el Museo Hergé
Em parceria com o Museu Hergé
与埃尔热博物馆合作
We współpracy z Muzeum Hergé
Ve spolupráci s Muzeem Hergé
V spolupráci s Muzeom Hergé
A Hergé Museummal együttműködésben
У партнерстві з музеєм Ерже
In parteneriat cu Muzeul Hergé
Съвместно с музей „Ерже”
Sadarbībā ar Hergé muzeju
Koostöös Hergé muuseumiga
Sukurta bendradarbiaujant su Hergé muziejumi
Hergé Müzesi ile iş birliği içinde

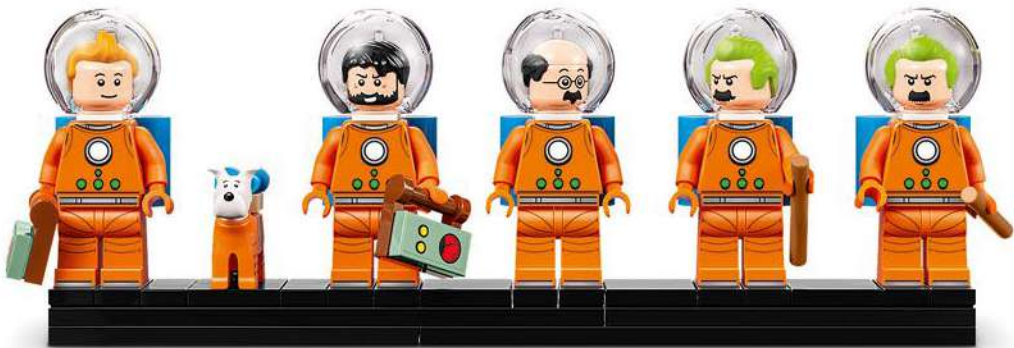

LEGO and the LEGO logo are trademarks of the LEGO Group. ©2026 The LEGO Group.

©Hergé-Tintinimaginatio - 2026

 6640661