

NEED HELP?

Contact us at [Jabra.com/contact](https://www.jabra.com/contact)

2 Jahre Garantie mit Jabra Sound+ App registrieren

Enregistrez votre garantie de 2 ans avec l'application Jabra Sound+

Registre su garantía de 2 años con la aplicación Jabra Sound+



GET STARTED

ELITE ACTIVE 65t

REGISTER YOUR 2-YEAR WARRANTY

with the Jabra Sound+ app



Jabra Sound+ app



Personalize
your music



Customize
HearThrough



Register your
2-year warranty



Download on the
App Store



GET IT ON
Google play

ENGLISH	1
FRANÇAIS.....	5
DEUTSCH.....	9
NEDERLANDS	13
ITALIANO	17
PORTUGUÊS.....	21
ESPAÑOL.....	25
MAGYAR	29
ROMÂNĂ.....	33
SUOMI.....	37
РУССКИЙ.....	41
DANSK/SVENSKA	45
ČESKY	49
УКРАЇНСЬКА	53
POLSKI.....	57
TÜRKÇE.....	61
ΕΛΛΗΝΙΚΑ.....	65
69	العربية
73	فارسی

How to pair

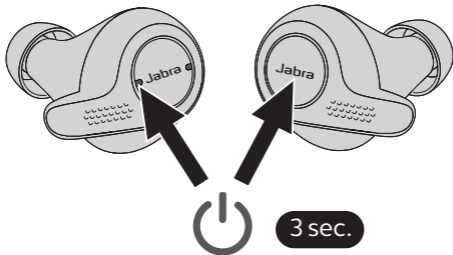

Hold (3 secs) the button on the right earbud and the left button on the left earbud to power on, and then follow the voice instructions to pair to your phone.

How to fit

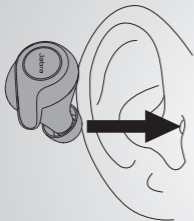

Insert

the earbud into your ear.



Rotate

the earbud to fit snug inside your ear canal. The microphone should point towards your mouth.

How to use

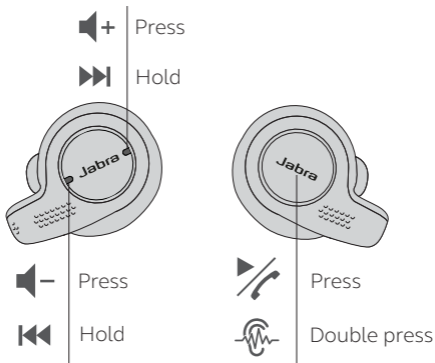

How to charge

5 hours
battery

2 recharges
on-the-go

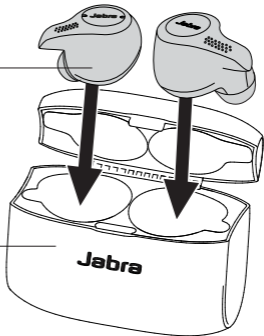

Instructions d'appairage

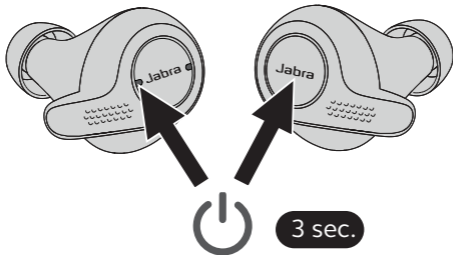

Appuyez pendant 3 secondes sur le bouton de l'écouteur droit et le bouton de l'écouteur gauche pour les allumer, puis suivez les instructions vocales pour les appairer avec votre téléphone.

Instructions de port

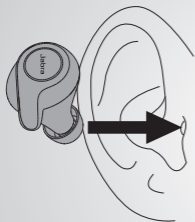

Insérez

l'écouteur dans votre oreille.



Faites tourner

l'écouteur afin de bien le placer dans votre conduit auditif. Le microphone doit être orienté en direction de votre bouche.

Instructions d'utilisation

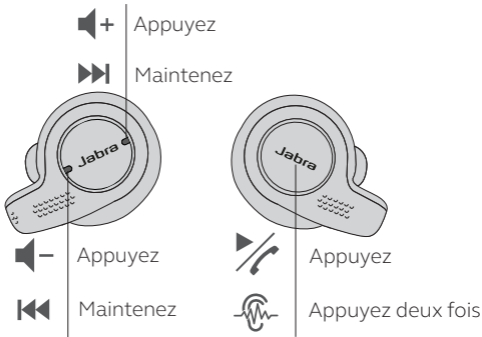

Instructions de charge

5 heures
batterie

2 recharges
mobiles

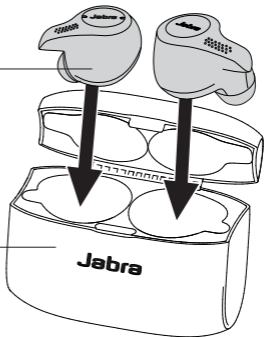

Kopfhörer koppeln

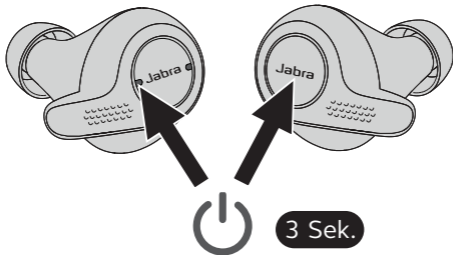

Zum Einschalten halten Sie die linke Taste am linken Kopfhörer zusammen mit der Taste am rechten Kopfhörer 3 Sek. lang gedrückt und folgen dann den Anweisungen für eine Verbindung mit Ihrem Smartphone.

Kopfhörer einsetzen

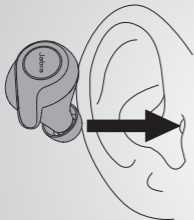

Setzen

Sie den Kopfhörer ins Ohr ein.



Drehen

Sie den Kopfhörer, bis er fest im Gehörgang sitzt. Achten Sie darauf, dass das Mikrofon in Richtung Ihres Mundes zeigt.

Kopfhörer verwenden

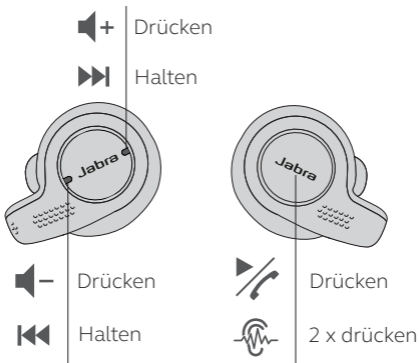

Akku aufladen

5 Stunden
Akku

2 Aufladungen
unterwegs

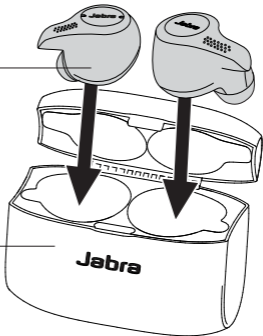

Koppelen

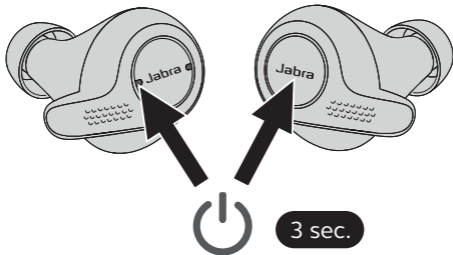

Houd de knop op het rechteroordopje en de linkerknop op het linkeroordopje 3 seconden ingedrukt om ze aan te zetten. Volg vervolgens de gesproken instructies om te koppelen met uw telefoon.

Pasvorm

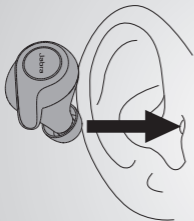

Plaats

het oordopje in uw oor.



Draai

het oordopje zodat het stevig in uw gehoorkanaal zit. De microfoon moet naar uw mond gericht zijn.

Gebruiken



Drukken



Vasthouden

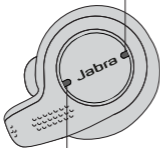

Drukken



Vasthouden

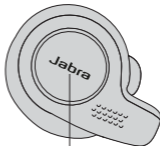

Drukken



Tweemaal drukken

Opladen

5 uur
batterij

2 keer opladen
onderweg

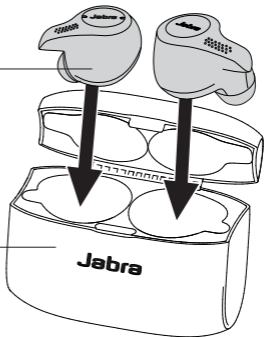

Come accoppiarli

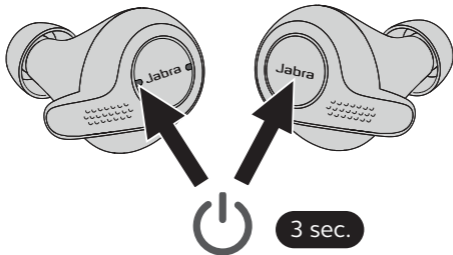

Tieni premuto per tre secondi il tasto sull'auricolare destro e il tasto sinistro sull'auricolare sinistro per accendere e poi segui le istruzioni vocali per accoppiare il telefono.

Come trovare la vestibilità ^{IT}

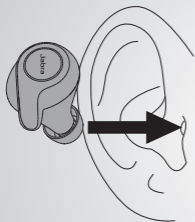

Inserisci

l'auricolare nell'orecchio.



Ruota

l'auricolare in modo che si adatti in maniera salda al canale auricolare. Il microfono deve essere rivolto verso la bocca.

Come utilizzarli

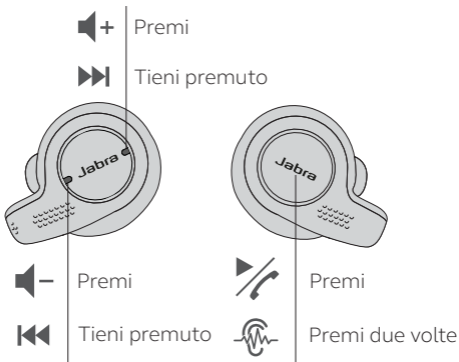

Come caricarli

5 ore
di batteria

2 ricariche
in movimento

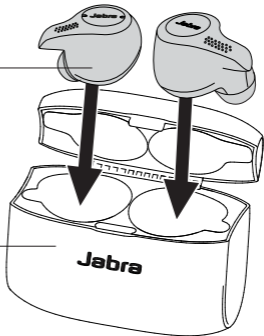

Como emparelhar

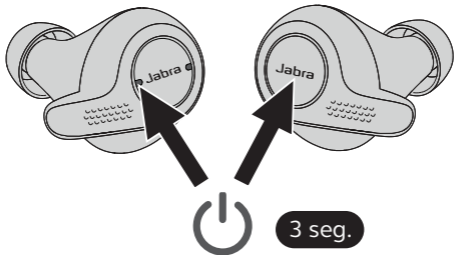

Prima (3 seg.) o botão no auricular direito e o botão no auricular esquerdo para ligar e, de seguida, siga as Instruções de Voz para emparelhar com o seu telefone.

Como ajustar

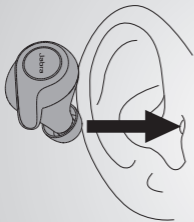

Insira

o auricular no seu ouvido.



Gire

o auricular de forma a ajustar-se ao interior do seu canal auditivo. O microfone deverá estar direcionado para a sua boca.

Como utilizar

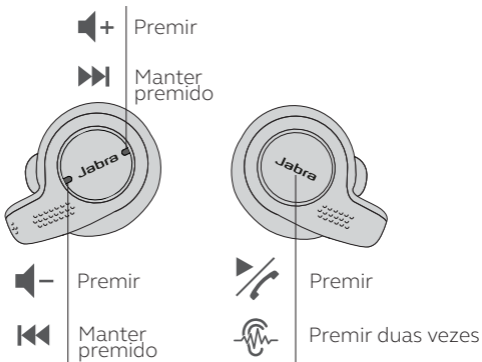

Como carregar

5 horas
de bateria

2 recargas
em viagem

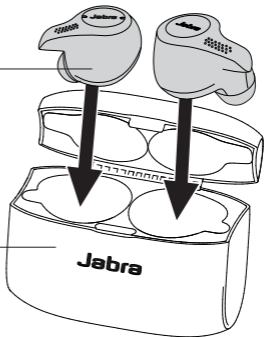

Cómo se sincroniza

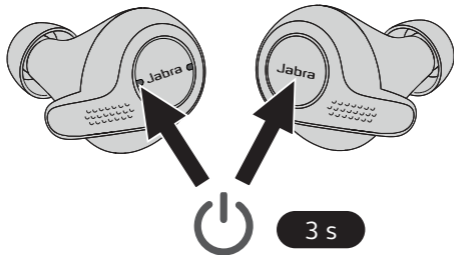

Mantenga pulsado (3 segundos) el botón del auricular derecho y el botón izquierdo del auricular izquierdo para encender y siga las instrucciones de voz para sincronizar su teléfono.

Cómo se ajusta

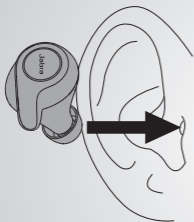

Inserte

el auricular en el oído.



Rote

el auricular para que se ajuste al interior de su l conducto auditivo. El micrófono debe estar orientado hacia la boca.

Cómo se usa



Pulsar



Mantener pulsado

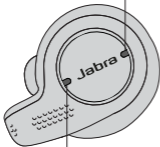

Pulsar



Mantener pulsado

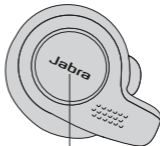

Pulsar



Pulsar dos veces

Cómo se carga

5 horas
de batería

2 recargas
en cualquier lugar

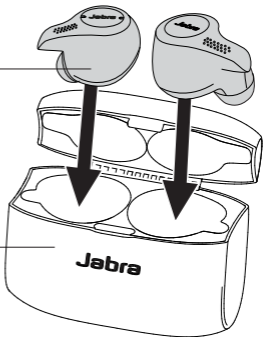

A fejhallgató társítása

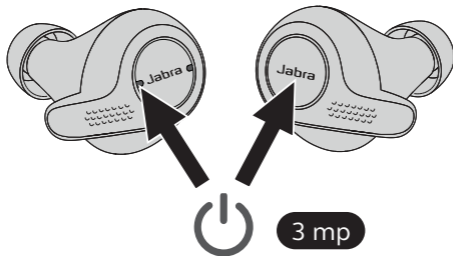

A bekapcsoláshoz tartsa lenyomva (3 mp-ig) a jobb oldali füldugón levő gombot, illetve a bal oldali gombot a bal oldali füldugón, majd telefonja társításához kövesse a hangos útmutatásokat.

Hogyan illessze be

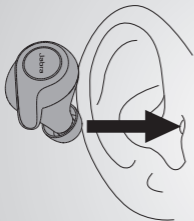

Helyezze

a fül dugót a fülébe.



Fordítsa el

a fül dugót, hogy pontosan
illeszkedjen a fülcsatornába.
A mikrofon a szája felé mutasson.

A fejhallgató használata



Nyomja meg



Tartsa lenyomva

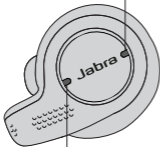

Nyomja meg



Tartsa lenyomva

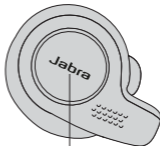

Nyomja meg



Nyomja meg kétszer

A fejhallható feltöltése

5 óra
akkumulátor

2 újratöltés
menet közben

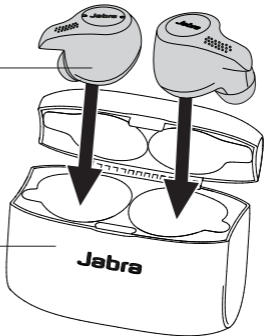

Realizarea perechii

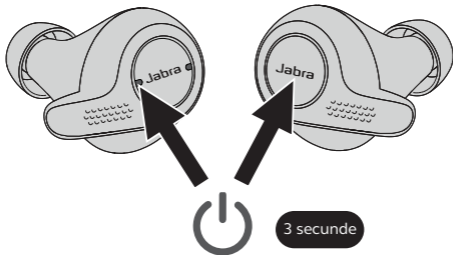

Țineți apăsată (3 secunde) butonul de pe casca dreaptă și butonul de pe casca stângă pentru pornire, după care urmați instrucțiunile vocale pentru a realiza perechea cu telefonul dvs.

Potrivirea

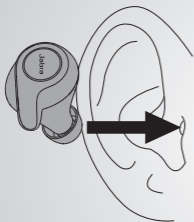

Introduceți

casca internă în urechea dvs.



Rotiți

casca internă pentru a se potrivi bine în interiorul canalului auricular. Microfonul trebuie îndreptat spre gura dvs.

Utilizarea

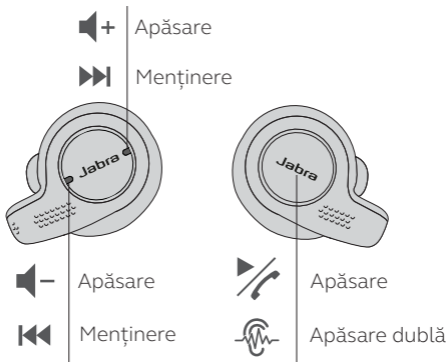

Încărcarea

5 ore
pentru baterie

2 reîncărcări
în mișcare

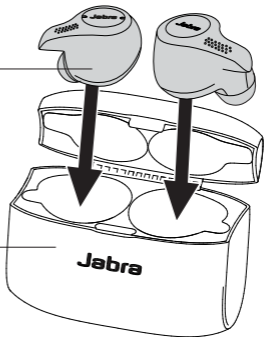

Pariliitoksen muodostaminen

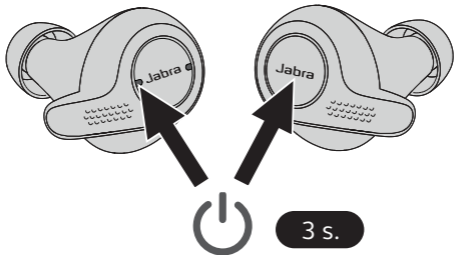

Pidä (3 sekunnin ajan) oikean ja vasemman korvanapin painikkeita painettuna kytkeäksesi virran päälle ja seuraa sen jälkeen ääniohjeita muodostaaksesi puhelimeesi pariliitoksen.

Kuinka sovittaa

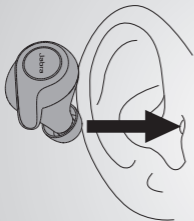

Aseta

korvanappi korvaasi.



Käännä

korvanappia sovittaaksesi sen korvakanavaasi. Mikrofonin pitäisi olla kohti suutasi.

Käyttötapa

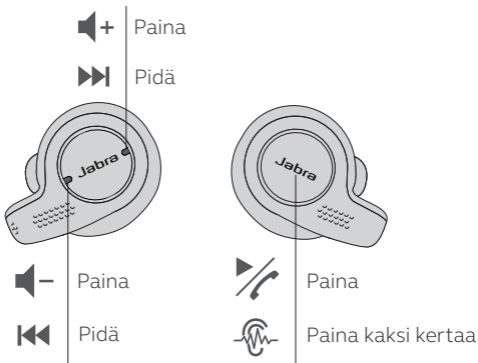

Lataaminen

5 tuntia
akku

2 lisälatausta
tien päällä

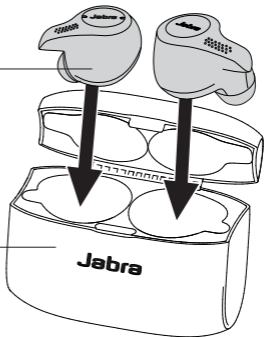

Сопряжение

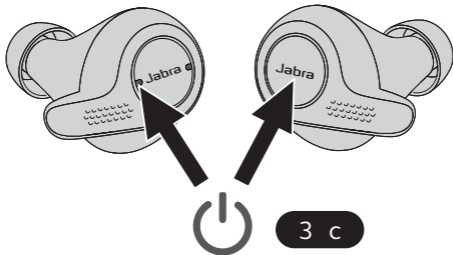

Удерживайте (3 секунды) кнопку на правом наушнике и кнопку на левом наушнике, чтобы включить наушники, и затем следуйте голосовым указаниям по выполнению сопряжения с Вашим телефоном.

Подгонка

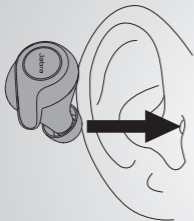

Вставьте

наушник в ухо.



Поверните

наушник для обеспечения плотной посадки в ушном канале. Микрофон должен быть направлен в сторону Вашего рта.

Использование



Способ зарядки

5 часов работы от аккумулятора

2 подзарядки на ходу

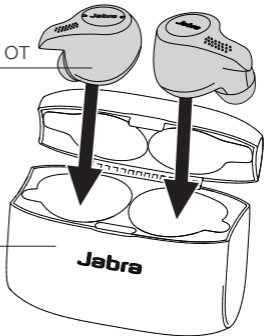

Sådan parrer (kopplar ihop) du headsettet

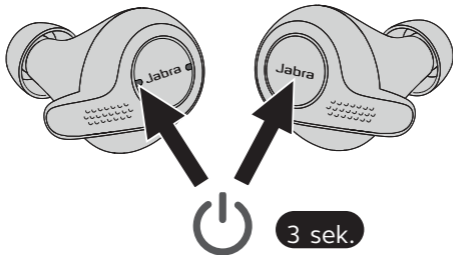

Hold knappen på højre øreprop (höger öronsnäcka) og den venstre knap på den venstre øre prop nede (vänster öronsnäcka) (3 sek.) for at tænde (sätta på), og følg så stemmevejledningen (röstguiden) for at parre (koppla ihop) det med din telefon.

Sådan tilpasses (justeras passformen) det

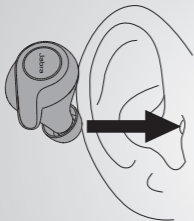

Indsæt (sätt in)

Øreproppen (öronsnäckan)
i dit øre.

Drej (Vrid)

Øreproppen (öronsnäckan) til den
sitter tilpas (tjæt) i din øregang
(hörselgång). Mikrofonen bør vende
(riktas) mod din mund.

Sådan bruges (anvendes) headsettet



Tryk



Hold (håll in)

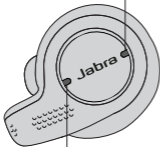

Tryk



Hold (håll in)

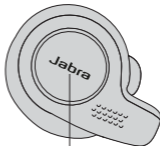

Tryk



Tryk to gange
(två gånger)

Sådan oplades (laddas) det

5 timers
Batteri

2 genopladninger
(återuppladdningar)
på farten

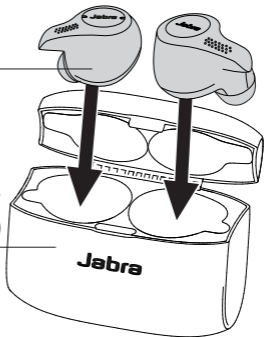

Postup párování

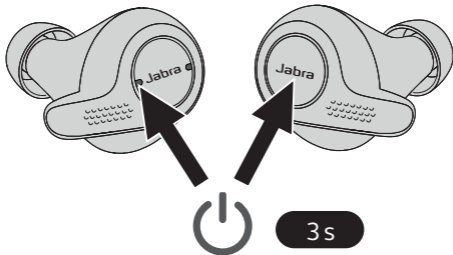

Zapněte napájení přidržením tlačítka na pravém peckovém sluchátku na dobu 3 sekund, a současným stiskem levého tlačítka na levém peckovém sluchátku.

Postup nasazení

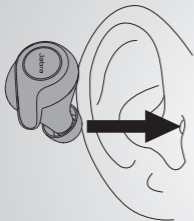

Peckové

sluchátko vložte do ucha.



Pootočte

peckové sluchátko tak, aby se optimálně vešlo do zvukovodu. Mikrofon by měl směřovat k ústům.

Způsob použití

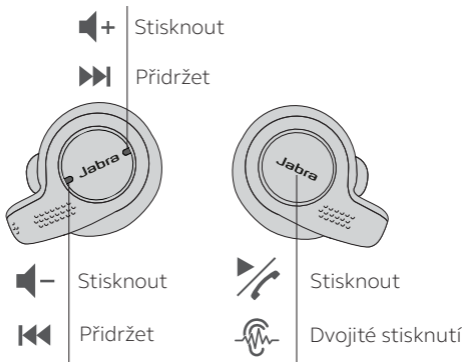

Nabíjení

5 hodin
Baterie

2 nabití
Na cestách

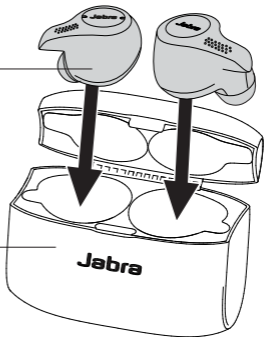

З'єднання

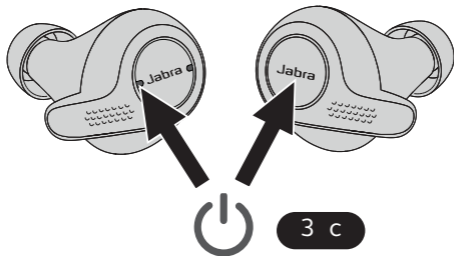

Утримуйте (3 секунди) кнопку на правому навушнику і кнопку на лівому навушнику, щоб увімкнути навушники, та додержуйтесь голосових інструкцій щодо з'єднання з Вашим телефоном.

Підгонка

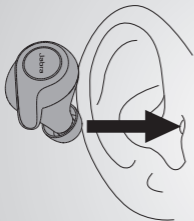

Вставте



наушник у вухо.





Поверніть

наушник для забезпечення щільної посадки у вушному каналі. Мікрофон має бути спрямований у бік Вашого рота.

Використання

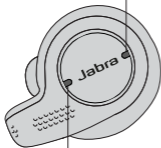
 Натиснення
 Утримання



 Натиснення
 Утримання

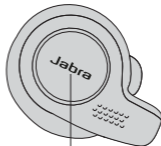

 Натиснення
 Подвійне натиснення

Спосіб заряджання

5 годин роботи від
акумулятора

2 підзарядки
на ходу

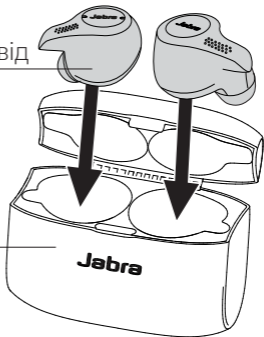

Parowanie

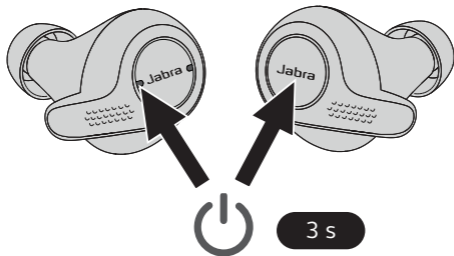

Przytrzymaj (3 s) przycisk na prawej słuchawce dousznej oraz lewy przycisk na lewej słuchawce dousznej, aby włączyć opcję parowania, a następnie wykonuj instrukcje głosowe, aby sparować z telefonem.

Dopasowanie

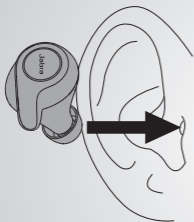

Włóż

stuchawkę douszną do ucha.



Obróć

stuchawkę douszną, aby dobrze dopasować ją do kanału słuchowego. Mikrofon powinien być skierowany w stronę ust.

Obsługa



Naciśnij



Przytrzymaj

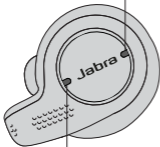

Naciśnij



Przytrzymaj

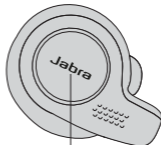

Naciśnij



Naciśnij
dwukrotnie

Ładowanie

5 h

bateria

2

ładowania
w drodze

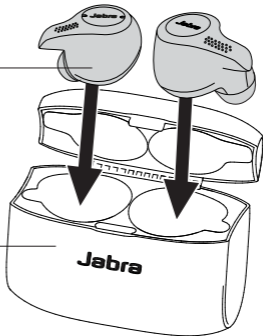

EŐLEŐTİRME

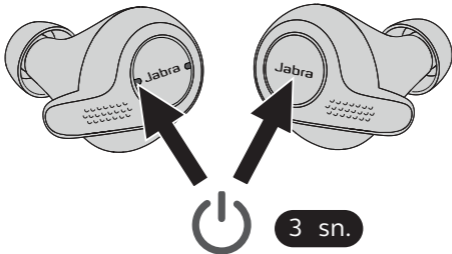

Sađ kulaklıkta ve sol kulaklıkta bulunan düğmeleri basılı tutarak (3 saniye) kulaklıđı çalıştırın ve ardından telefonunuzla eşleőtirmek için sesli talimatları izleyin.

Kulaklıđı takma

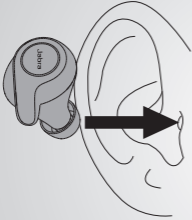

Yerleřtirin

Kulaklıđı kulađınıza yerleřtirin.



Döndürün

Kulaklıđı kulak kanalınıza sıkıca oturacak řekilde döndürün. Mikrofon her zaman ađzınıza dönük olmalıdır.

Kullanım

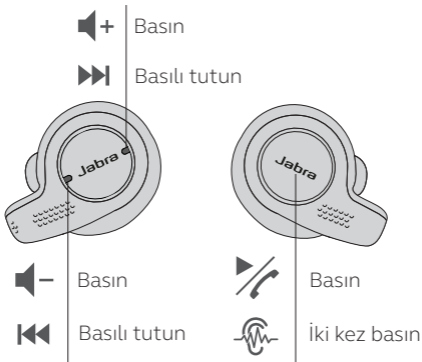

Şarj etme

5 saat
sürelî batarya

2 kez şarj
edebilen şarj
birimi

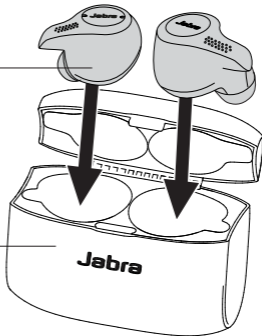

ΤΡΟΠΟΣ ΖΕΥΞΗΣ

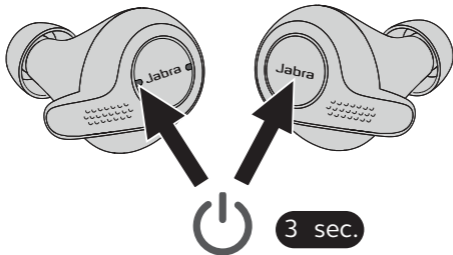

Κρατήστε (3 δευτερόλεπτα) το κουμπί στο δεξιό ακουστικό το αριστερό κουμπί στο αριστερό ακουστικό για να το ενεργοποιήσετε, και μετά ακολουθήστε τις φωνητικές οδηγίες για να συνδέσετε το τηλέφωνο σας.

Τρόπος εφαρμογής

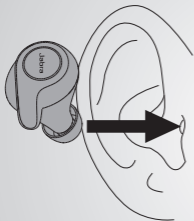

Βάλτε

το ακουστικό στο αυτί σας.



Περιστρέψτε

το ακουστικό για ταιριάζει σταθερά μέσα στο κανάλι του αυτιού. Το μικρόφωνο πρέπει να είναι στραμμένο προς το στόμα σας.

Τρόπος χρήσης



Πατήστε



Κράτημα

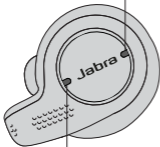

Πατήστε



Κράτημα

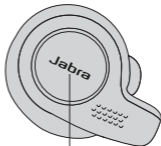

Πατήστε



Διπλό πάτημα

ΤΡΟΠΟΣ ΦΟΡΤΙΣΗΣ

5 ώρες
μπαταρία

2 επαναφορτίσεις
εν κινήσει

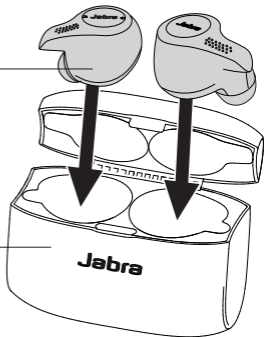

كيفية الإقران

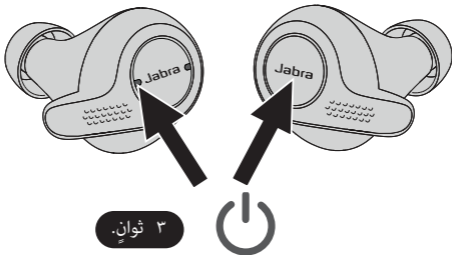

اضغط مع الاستمرار لمدة (٣ ثوانٍ) على الزر الموجود على السماعة اليمنى والزر الأيسر الموجود على السماعة اليسرى للتشغيل، ثم اتبع التعليمات الصوتية لإقران لهاتفك.

كيفية الارتداء

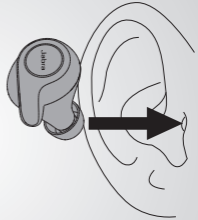

قم بتدوير

سماعة الأذن لتتلاءم داخل قناة
أذنك بكل أريحية. يجب أن يشير الميكروفون إلى فمك.

أدخل

سماعة الأذن في أذنك.

كيفية الاستخدام



اضغط



استمر في الضغط

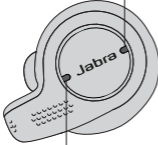

اضغط



اضغط ضغطاً مزدوجاً

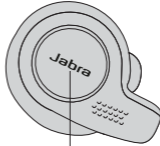

اضغط



استمر في الضغط

كيفية الشحن

5 ساعات
بطارية

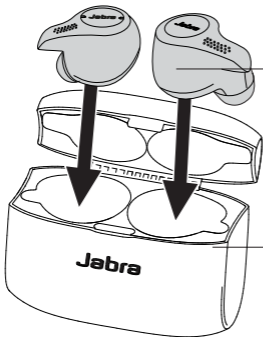

2 لإعادة الشحن
أثناء التنقل

نحوه تعمیر

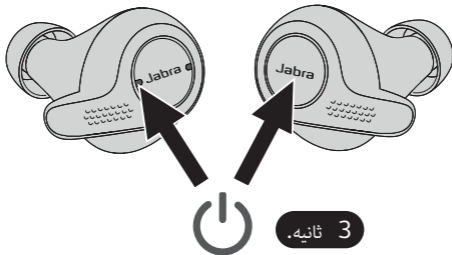

دکمه سمت راست گوشی و دکمه سمت چپ گوشی را (3 ثانیه) دارید تا روشن شود و سپس دستورالعمل صوتی را برای جفت‌سازی با تلفن‌تان دنبال کنید.

نحوه جایگیری

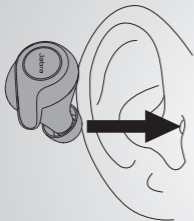

گوشی

را داخل گوش خود وارد کنید.



گوشی

را بچرخانید تا به اندازه داخل کانال گوش جا شود.
میکروفون باید به سمت دهانتان باشد.

روش شارژ کردن

5 ساعت
باتری

2 شارژ مجدد
در حال حرکت

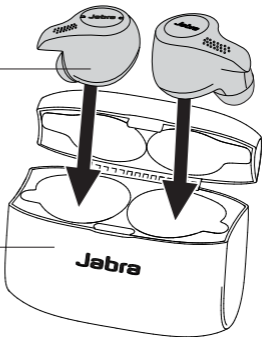

نحوه استفاده



برای



نگه دارید

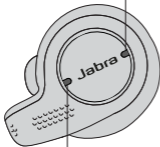

برای



نگه دارید

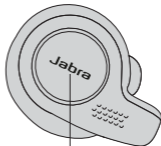

برای



دوبار فشار دهید

iPhone is trademark of Apple Inc., registered in the U.S. and other countries.

“Made for iPhone” mean that an electronic accessory has been designed to connect specifically to iPhone and has been certified by the developer to meet Apple performance standards. Apple is not responsible for the operation of this device or its compliance with safety and regulatory standards. Please note that the use of this accessory with iPhone may affect wireless performance.



Bluetooth technology works with iPhone 8, iPhone 8 Plus, iPhone 7, iPhone 7 Plus, iPhone 6, iPhone 6 Plus and iPhone 5S.



Agência Nacional de Telecomunicações

08145-18-05774

Este equipamento não tem direito à proteção contra interferência prejudicial e não pode causar interferência em sistemas devidamente autorizados

© 2018 GN Audio A/S. All rights reserved. Jabra® is a trademark of GN Audio A/S. The Bluetooth® word mark and logos are registered trademarks owned by the Bluetooth SIG, Inc. and any use of such marks by GN Audio A/S is under license.

MADE IN CHINA
MODEL: OTE070 / OTE071
/ CPB070



Declaration of Conformity can be found on
www.jabra.com/doc