

MesMed

MESCOMP
TECHNOLOGIES



USER MANUAL PULSE OXIMETER MM-155 OXYmed

THANK YOU FOR BUYING OUR BRAND PRODUCTS.
WE WISH YOU A PLEASANT USE.
BEFORE USING THE DEVICE FOR THE FIRST TIME, PLEASE READ THE
USER MANUAL.

Table of content:

1. CHARACTERISTICS AND FUNCTIONS	2
2. PLEASE READ BEFORE TURN ON THE DEVICE	3
3. CAUTIONS OF USE.....	3
4. PRECAUTIONS	4
5. PRINCIPLES OF OPERATION OF THE PULSOXYMETER	6
6. TECHNICAL SPECIFICATION	6
7. DEVICE DESCRIPTION.....	6
8. INSTALLATION OF BATTERIES.....	7
9. TAKING THE MEASUREMENT.....	7
10. CLEANING AND DISINFECTION	8
11. SOLUTIONS OF EASY TROUBLES	8
12. STANDARDIZED MARKINGS	8

1. CHARACTERISTICS AND FUNCTIONS

The high-quality finger pulse oximeter is designed for quick and non-invasive measurement of pulse and blood saturation in both adults and children over four years of age. By monitoring the saturation of hemoglobin with oxygen, various types of diseases and infections can be detected. For easier and more accurate measurement, our company offers you a pulse oximeter that measures both saturation and heart rate. It is extremely simple and convenient to use - just put it on your finger and press one button.

It is a completely non-invasive and painless test that anyone can do on their own. It is enough for the patient to put one of the fingers into the sensor for diagnosis, and the display screen after a few seconds will show the directly measured value of the oxygen saturation of hemoglobin and the pulse.

- Measurement of blood oxygen saturation (SpO₂).
- Heart rate measurement.
- Pulse intensity indicator.
- Bar and wave graph - display of heart rate.
- Clear, color, high-quality TFT display.
- Change the display direction.
- Convenient and easy one-key operation.
- Fast measurement.
- Small size, light, easy to carry.
- Very low battery consumption.
- Automatic switch-off after 5 sec.
- Lanyard.

CAUTION:

MESCOMP TECHNOLOGIES reserves the right to make changes to the hardware and software resulting from technological progress.

2. PLEASE READ BEFORE TURN ON THE DEVICE

Please read the manual carefully before using this equipment.

Failure to follow these instructions could result in:

- measurement irregularities,
- damage to equipment,
- personal injury.

CAUTION:

The warranty for the devices does not cover damage from improper use, incompatible with the user manual.

3. CAUTIONS OF USE

- Fingers that are too thin or too cold may affect the measurement result and cause the SpO₂ and pulse rate readings to be incorrect. In this case, insert a thick finger, such as a thumb or middle finger, deep enough into the probe.
- Do not use the device on infants or neonates.
- The product is suitable for children over four years of age and adults (the weight should be between 15 kg and 110 kg).
- The examined person must not have painted nails.
- The subject's nails must not be too long.
- If stable readings cannot be obtained, stop measuring. The device may not work properly for all patients.
- If the screen displays abnormal indications during the test, pull your finger out and reinsert it to restore normal operation.
- Read the measured value when the pulse waveform is normalized and the pulse waveform on the screen is even and stable.
- Contact your doctor if the device is working properly and the indications are outside the norm.

Clinical limitations

- Factors that may cause inaccurate measurements:

- o Poor heart rate

Significant pulsating blood flow is required for correct measurement. If you have a poor pulse due to shock, low ambient / body temperature, heavy bleeding, or use of a vasoconstrictor drug, your SpO₂ value will decrease.

- o Anemia, low hemoglobin, toxic hypoxia.

If you have severe anemia, the device may show abnormal SpO₂ measurements.

- o A significant amount of a diluting dye e.g. methylene blue, indigo green and acid indigo blue or carbon monoxide hemoglobin (COHB), methionine (Me + Hb) or hemoglobin, jaundice.
- o Drugs such as dopamine, procaine, prilocaine, lidocaine and butacaine.
- It is not recommended to use the device if the patient is suffering from carbon monoxide poisoning.

4. PRECAUTIONS



Before use, check the packaging to make sure that the device and accessories fully comply with the description and instructions. Otherwise the device may malfunction.



Periodically check the main unit and all accessories. Make sure there are no visible damage that may impact patient safety and monitor the performance of cables and transducers. It is recommended to check the device at least once a week. Discontinue use of the device in the event of obvious damage.



It is not recommended to use the oximeter in a high electromagnetic frequency environment. Do not use the oximeter during MRI and CT examinations.



Do not use the device on people allergic to rubber.



Do not use the oximeter in an environment with flammable gases such as certain flammable anesthetics. Using in these conditions may cause an explosion.



Do not disassemble or change the configuration on your own. Except as described in the manual – SOLUTIONS OF EASY TROUBLE section.

CAUTION:

Do not repair the unit yourself. Necessary repair and maintenance work must **ONLY** be performed by qualified service engineers. Users are not allowed to maintain or repair the device themselves.



It is recommended that the sensor is not continuously applied to the same finger for more than 2 hours. Continued use of the device may cause an unpleasant or painful sensation, especially in patients with a microcirculation barrier. The device must not be used on swollen, irritated or oversensitive skin.



The light (infrared is invisible) emitted from the device is harmful to the eyes, so the user cannot look at them.



This device is not intended for medical treatment. The device does not have an alarm function with incorrect parameters.



Keep the oximeter away from dust, vibration, corrosive substances, explosives, heat, and moisture.



Do not use the oximeter if it becomes wet. Do not immerse the oximeter in liquid. Do not spray any liquid directly onto the device.



Do not use the oximeter immediately after it has been transferred from a cold environment to a warm or humid environment.



Do not press the buttons on the front panel with sharp materials. The flexible circuit connects the two parts of the device and should not be twisted or pulled.



Remove the batteries if the device is to be stored for more than a month, otherwise leakage may occur.



The product lanyard is made of anti-allergic material. If the lanyard causes an allergic reaction, stop using it. Do not wear a lanyard around your neck.



The device does not have low voltage alarm function, only shows low voltage, please replace the battery when the battery power is used up.



Environmental Requirements:

a. Storage environment:

- Temperature: $-10^{\circ}\text{C} \sim +40^{\circ}\text{C}$
- Relative humidity: 15%-85%
- Atmospheric pressure: 500hPa-1060hPa

b. Work environment:

- Temperature: $10^{\circ}\text{C} - 40^{\circ}\text{C}$
- Relative humidity: 15%-85%
- Atmospheric pressure: 700 hPa-1060 hPa

5. PRINCIPLES OF OPERATION OF THE PULSOXYMETER

The finger pulse oximeter is used to measure blood saturation, i.e. SpO₂ oxygenation and pulse in real time. It allows you to examine the level of hypoxia in the body, which is dangerous to human health and life.

The principle of operation of the pulse oximeter is that, according to the technology of scanning and recording capacitive pulses, it measures the radiation absorbed by red blood cells with two wavelengths: infrared and red. Based on the measurement, using the method of transmission spectrophotometry, it measures the differences in the optical properties of oxygenated and non-oxygenated hemoglobin and calculates the degree of hemoglobin saturation with oxygen (SpO₂).

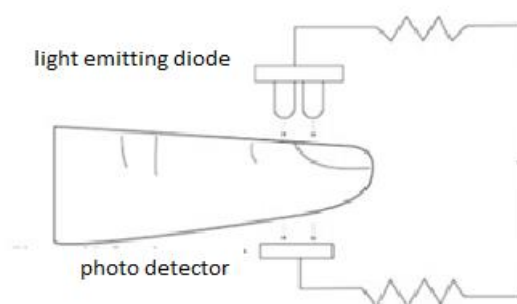

Rys. 1

6. TECHNICAL SPECIFICATION

- Display: TFT
- Pulse wave display: bar graph
- SpO₂ measurement range: 0% - 100%;
- Accuracy: 70% -100% ± 2%, below 70% undefined
- Optical sensor: red light (wavelength 660nm, 6.65mW)
- infrared (wavelength 880nm, 6.75mW)
- Heart rate measuring range: 30bpm - 250bpm
- Heart rate resolution: 1 bpm
- Measurement accuracy: ± 2% (70% - 100%)
- PR Measuring range: 25-250 strokes / min.
- PR accuracy: ± 2% bpm
- Resolution: SpO₂: 1%
- Ambient light resistance: <1%
- Battery type: 2 x 1.5V AAA alkaline.
- Power consumption: less than 30 mA
- Product size: 60 x 32 x 32mm
- Product weight: 63g
- Package contents: device - pulse oximeter, lanyard, manual in polish and english

7. DEVICE DESCRIPTION

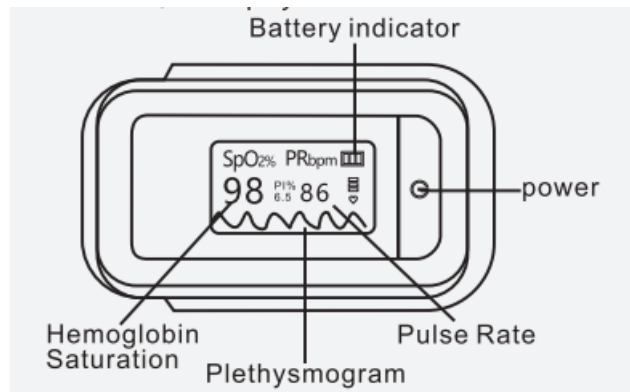

Rys.2

8. INSTALLATION OF BATTERIES

1. Insert the two AAA batteries correctly in the right direction.
2. Replace the cover.

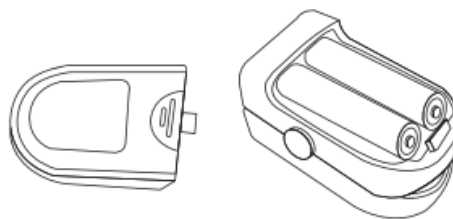

Rys. 4 Installation of batteries.

CAUTION:

- Be careful when inserting the battery as incorrectly inserting it may damage the device.
- Only use new alkaline or rechargeable batteries in the device.
- Using spent batteries may damage the device and void the warranty
- Before using the device for the first time or installing new batteries, wait about 10 minutes for the device to reach its operating temperature.
- Do not dispose of used batteries in a fire.

9. TAKING THE MEASUREMENT

1. Open the clip.

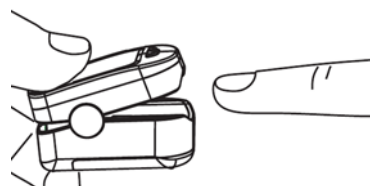

Rys.5

2. Place your finger on the rubber pads of the clip (make sure it is in the correct position), then pinch your finger.

CAUTION:

Nails and light emitting diode should be on the same side.

3. Press the switch button on the front panel once.
4. Do not swing your finger and stay calm. Do not make any movements during the measurement.
5. Get information directly from the screen.
6. The On button (see Rys. 2) has two functions:
 - a) When the device is turned off - pressing the button can open it.
 - b) When the device is turned on - a short press of the button can change the direction of the screen.

10. CLEANING AND DISINFECTION

- Turn off the device before cleaning.
- Clean the surface of the device before use. First wipe the device with medical alcohol and then allow it to air dry or clean with a dry, clean cloth.
- For cleaning, use a soft, clean cloth dampened with equipment cleaner.
- The device cannot be steam sterilized.

11. SOLUTIONS OF EASY TROUBLES

SpO2 and pulse rate cannot be displayed normally.

Place your finger correctly and try again.

SpO2 and heart rate are not steadily displayed.

Place your finger correctly, try again, and stay calm.

The device cannot be turned off.

Remove the battery. Reinstall the batteries.

If the machine still does not turn off, contact your local service center.











The display suddenly turns off.

This is normal - after 5 seconds without use, the device automatically turns off or the battery should be replaced.

12. STANDARDIZED MARKINGS

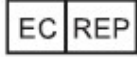

Follow the user manual.

	The presented symbol (the crossed-out image of a wheeled bin in accordance with Directive 2012/19 / EU-WEEE) indicates the recommendations in force in the European Union regarding separate collection of electrical waste and electronic equipment. Please do not throw this equipment into the trash with household waste.
	The packaging is recyclable.
RoHS	The product complies with the EU directive on the reduction of the amount of hazardous substances entering the environment from electrical and electronic waste.
	Parts of the type BF.
%SpO ₂	Pulse saturation with oxygen (%).
PR bpm	Puls rate (bpm).
	Serial number.
	Informations about manufacture.
	Date of production.
	Batch number.
IP 22	IP (degree of protection) of the device.
	The CE symbol means that this product has undergone an appropriate conformity assessment procedure and meets the essential safety, health, environmental and consumer requirements.
	Authorized representative in European Union.
	Wyrób medyczny.

Mescomp Technologies S.A.

Ul. Meksykańska 6. Lok. 102

03-948 Warszawa

Tel. + 48 (22) 636 20 00

mescomp.pl;

mesmed.pl



Service office: 03-948 Warszawa, Ul. Meksykańska 6, lok. 102

E-mail: mescomptel@mescomp.pl

tel. + 48 (22) 838 63 38

opening hours: 7.30 -15.30

date of actualization: 12.03.2020 r