



Create amazing spaces™

ITM. / ART. 17213624

ITM. / ART. 17213625

# DECO RECTANGLE PLANTER

USER MANUAL | MODE D'EMPLOI | **MANUAL DEL USUARIO** | MONTAGEANLEITUNG |  
MONTAGEHANDLEIDING | MANUALE PER L'UTENTE | **MANUAL DO UTILIZADOR**

**110** Kg  
**243** Lb

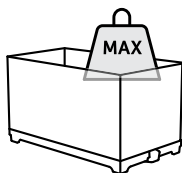

**140** Kg  
**309** Lb

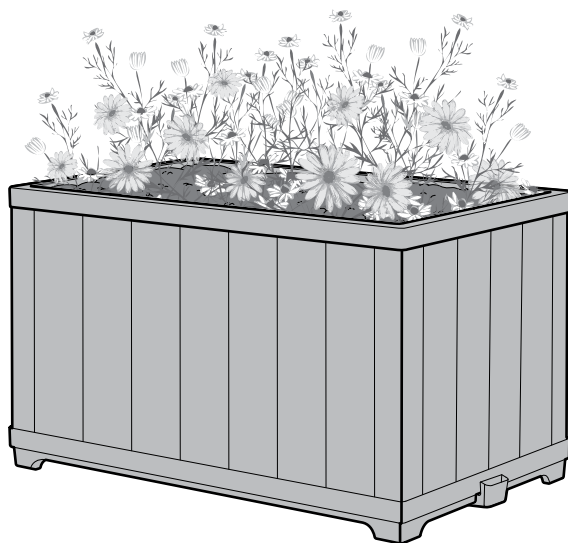
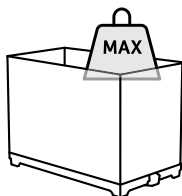

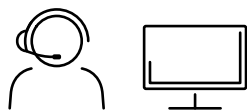
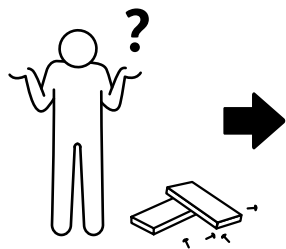

**WWW.KETER.COM**

**US, Canada: (EN/FR)**

[keter.com/en-us/contact-us.html](http://keter.com/en-us/contact-us.html)

Tel: +1-888-374-4262

Email: [NACS@keter.com](mailto:NACS@keter.com)

**UK**

Tel: +44-121-506-0008, [CSUK@keter.com](mailto:CSUK@keter.com)

Mon - Fri | 8am - 4pm

**For other European countries see the last page**

Autres pays européens, voir la dernière page

**Para otros países europeos vea la última página**

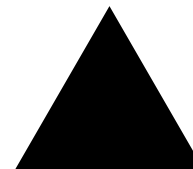

**OPTIMAL IRRIGATION GUIDE | GUIDE POUR UNE IRRIGATION OPTIMALE | GUIÀ PARA UN RIEGO ÓPTIMO | ANLEITUNG ZUR OPTIMALEN BEWÄSSERUNG | OPTIMALE IRRIGATIEHANDLEIDUNG | GUIDA PER UN'IRRIGAZIONE OTTIMALE | GUIDA ALL'IRRIGAZIONE OTTIMALE**

The Deco Rectangular Planter is equipped with an integral water basin and a drainage tray below. This makes it easy for you to grow beautiful, healthy plants that have all the moisture they need. All you need to do is keep an eye on the drainage tray water level. When the water drops to the minimum level, wait a few days and then water the plants. The number of days you wait depends on the type of plant and your growing environment. Please note: if you overwater your plant, excess water will spill over the drainage tray.

La jardinière rectangulaire Deco est équipée d'un bassin d'eau et d'un gobelet de drainage afin de vous permettre de cultiver plus facilement de belles plantes saines qui reçoivent toute la nourriture dont elles ont besoin. Il suffit de surveiller le niveau d'eau de la coupelle de drainage. Si le niveau d'eau descend à sa hauteur minimale, vous devez attendre quelques jours avant d'arroser vos plantes. Le nombre précis de jours d'attente dépend du type de plante et de l'environnement de culture. Veuillez noter que si vous arrosez trop votre plante, l'excès d'eau se répandra à l'extérieur de la coupelle de drainage.

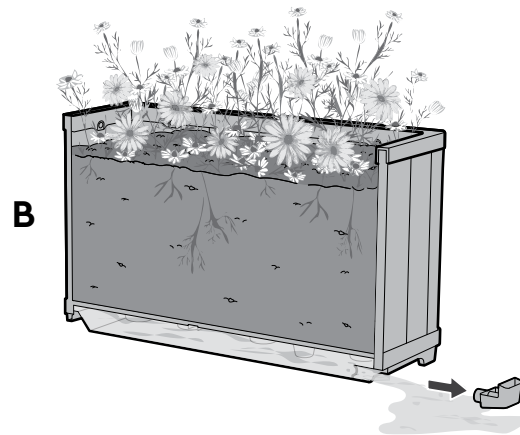
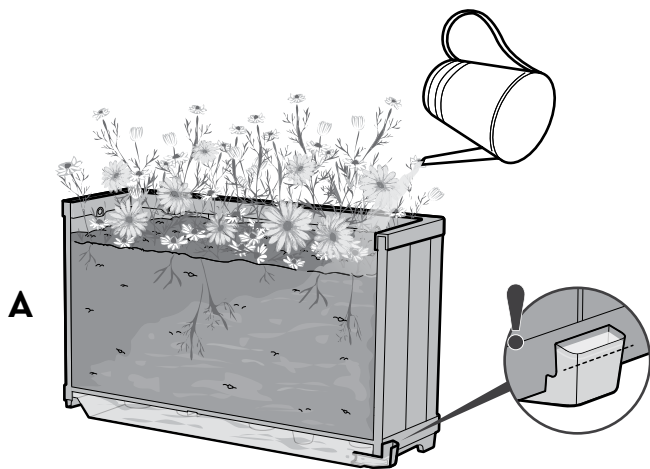

El macetero rectangular Deco está equipado con un recipiente de agua integrado y una bandeja de drenaje ubicada debajo. Esto le facilitará el cultivo de plantas hermosas y sanas que contarán con toda la humedad que necesiten. Todo lo que deberá hacer es vigilar el nivel de agua de la bandeja de drenaje. Cuando el agua baje al nivel mínimo, espere algunos días y solo entonces riegue las plantas. La cantidad de días que deberá esperar dependerá del tipo de planta y de su entorno de cultivo. Tenga en cuenta: si riega demasiado la planta, el exceso de agua se derramará sobre la bandeja de drenaje.





**Der dekorative rechteckige Pflanzentrog (Deco Rectangular Planter) verfügt über ein integriertes Wasserreservoir und hat unten einen Einsatz mit Bewässerungssystem. Damit gelingt die Anzucht schöner, gesunder Pflanzen, die ausreichend mit Feuchtigkeit versorgt sind, ganz leicht. Alles, worauf Sie achten müssen, ist der Wasserfüllstand im Einsatz. Nähert sich die Wasserfüllstandsanzeige der unteren Grenze, warten Sie ein paar Tage, bevor Sie die Pflanzen gießen. Die Wartezeit variiert je nach Pflanzenart und Wachstumsumgebung. Hinweis: Wenn Sie Ihre Pflanze überwässern, läuft das überschüssige Wasser in den Einsatz.**

De rechthoekige plantenbak van Deco heeft een ingebouwd waterbassin met onderin een afvoerbak. Hiermee kun je makkelijk mooie, gezonde planten kweken en krijgen ze alle voeding die ze nodig hebben. Het enige wat je hoeft te doen is het waterpeil van de afvoerbak in de gaten houden. Als het waterpeil tot het minimum is gezakt, wacht dan een paar dagen voor je de planten water geeft. Hoeveel dagen je precies moet wachten, is afhankelijk van het type plant en de omgeving. Let op: als je de plant te veel water geeft, kan de afvoerbak overstromen.

**O Vaso de Plantas Retangular Deco é equipado com uma bacia de água integral e com uma bandeja de drenagem por baixo. Isso facilita o cultivo de plantas bonitas e saudáveis, disponibilizando toda a umidade que precisam. Basta você ficar de olho no nível de água da bandeja de drenagem. Quando o nível de água atingir o seu mínimo, espere alguns dias e depois regue as plantas. O número de dias que você vai ter que esperar vai depender do tipo de planta e do ambiente de cultivo. Atenção: se você regar demais a sua planta, a bandeja de drenagem vai transbordar devido ao excesso de água.**

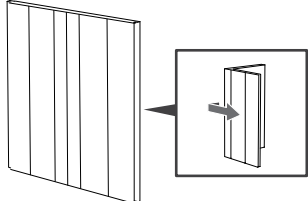
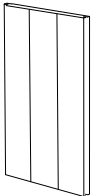
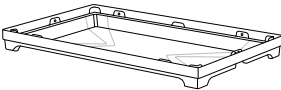
La fioriera rettangolare Deco è dotata di una vasca d'acqua integrata con vassoio di drenaggio sottostante. In questo modo le piante avranno tutta l'umidità di cui hanno bisogno e cresceranno sane e forti. È sufficiente tenere sotto controllo il livello dell'acqua nella vaschetta di drenaggio. Se l'acqua scende al livello minimo, bisogna aspettare qualche giorno prima di annaffiare le piante. Il numero esatto di giorni dipende dal tipo di pianta e dall'ambiente in cui è inserita. Attenzione: se si inaffia troppo la pianta, l'acqua in eccesso traboccherà dal vassoio di drenaggio.

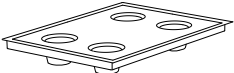
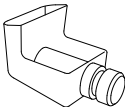
**ASSEMBLY PARTS | PIÈCES À ASSEMBLER | PIEZAS DE ENSAMBLE | MONTAGETEILE | PARTI DA MONTA RE | ONDERDELEN | PEÇAS DE MONTAGEM**

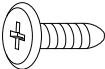
 <p>Corner (x4)</p>	 <p>Straight (x2)</p>	 <p>B (x1)</p>	 <p>T (x1)</p>	
 <p>F1 (x1)</p>	 <p>F2 (x1)</p>	 <p>D (x1)</p>	 <p>O-Ring (x1)</p>	 <p>Screw (x14)</p>

1



Corner (x1)

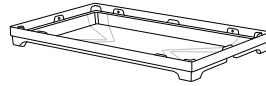

B (x1)

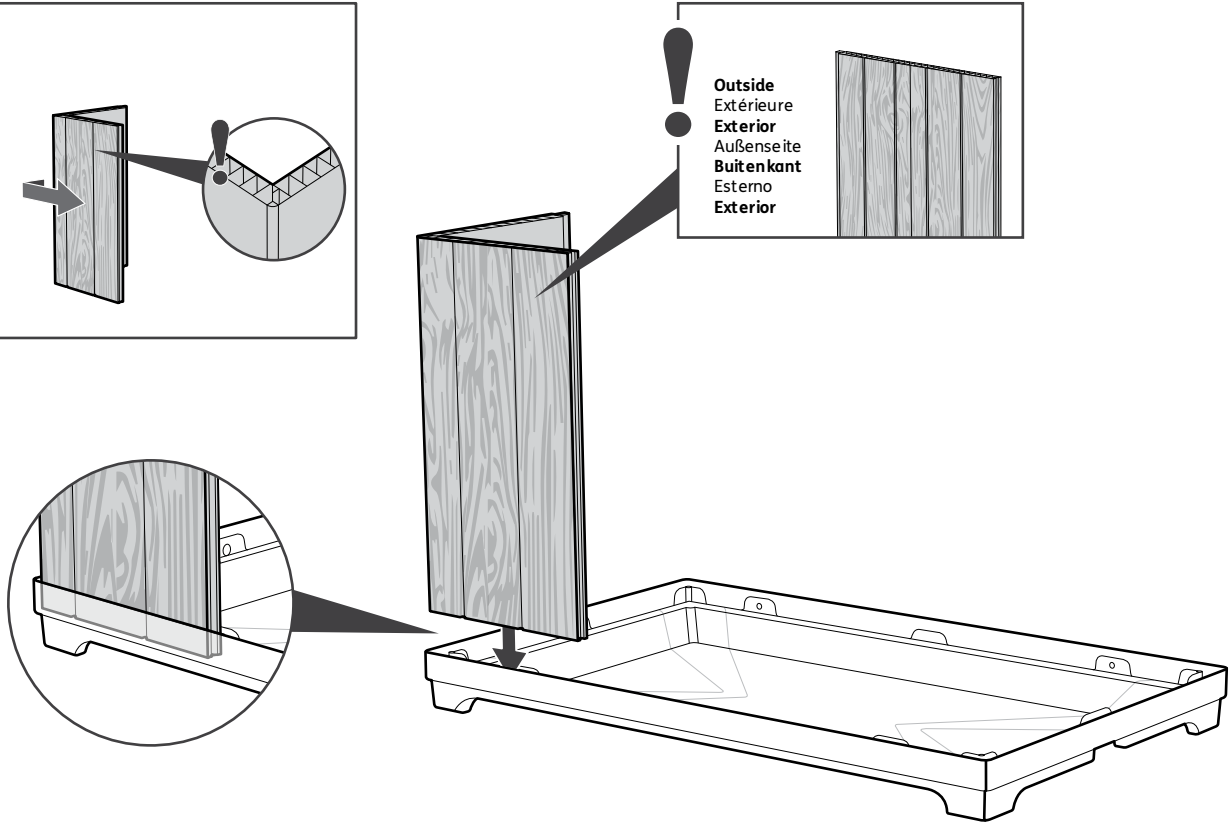
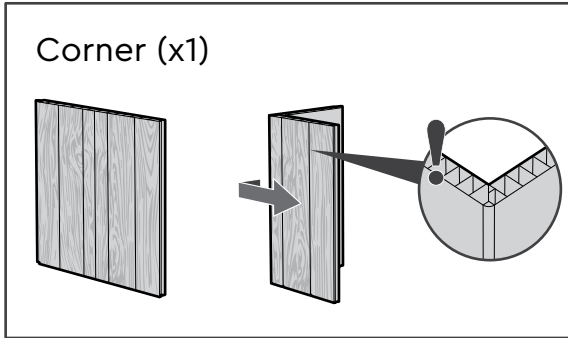

2



Corner (x3)

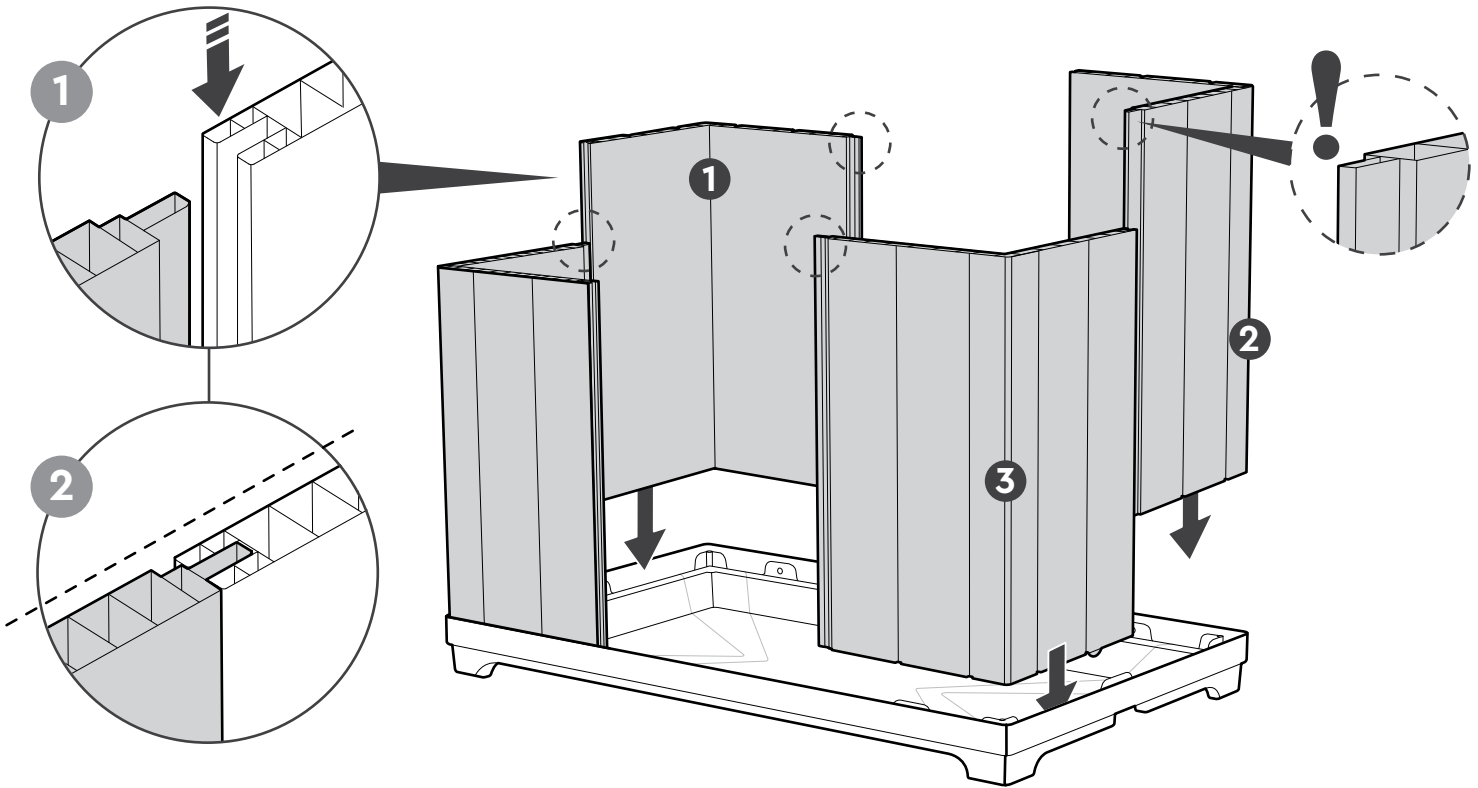

3



Straight (x2)

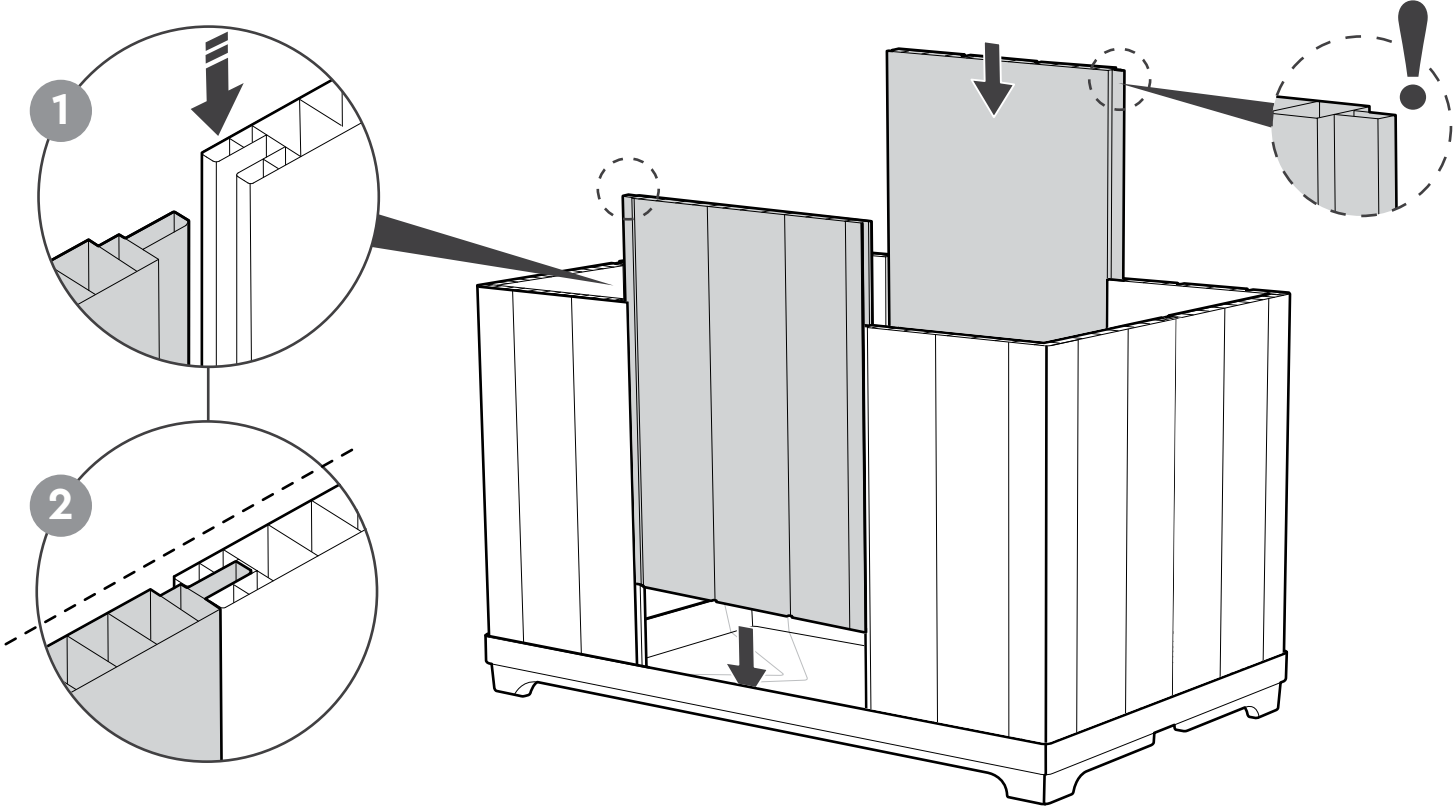

4

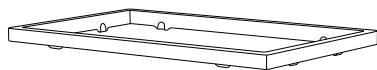

T (x1)

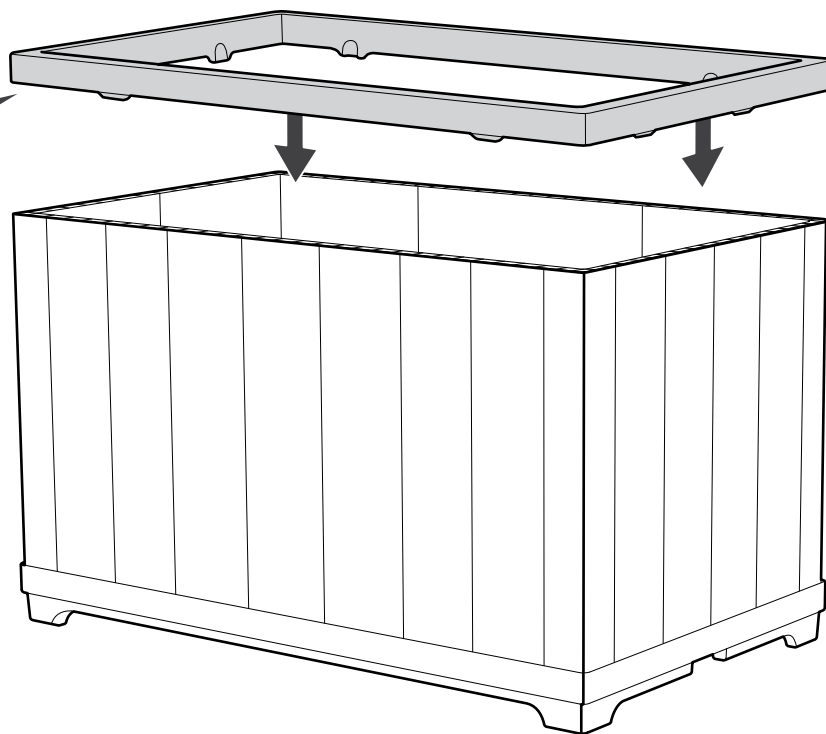
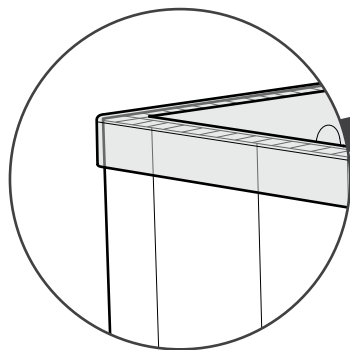

5

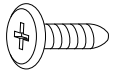

Screw (x6)

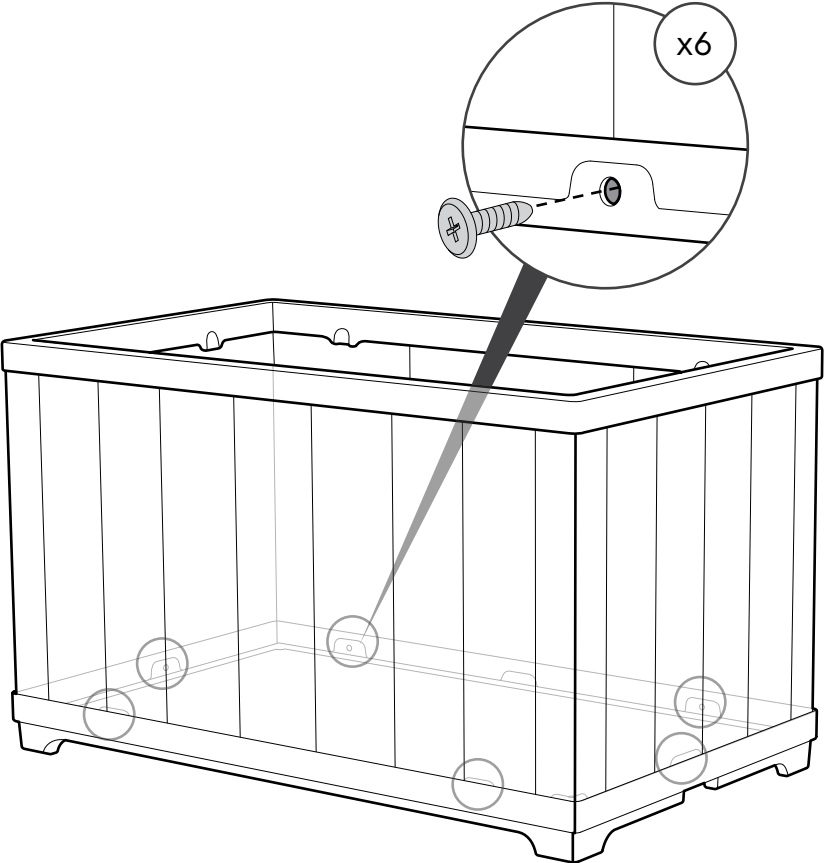

6

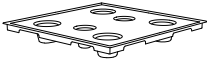

F1 (x1)

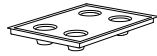

F2 (x1)

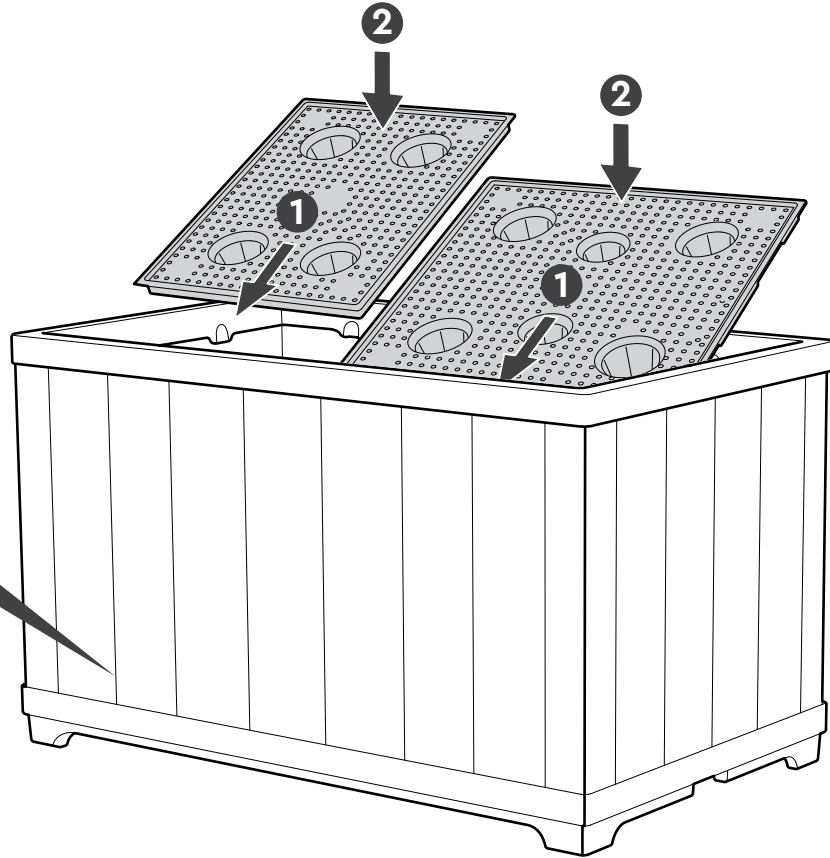
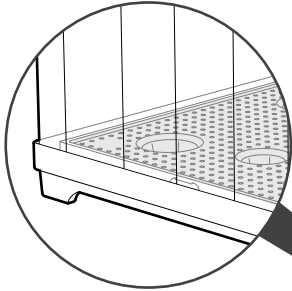

7

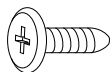

Screw (x8)

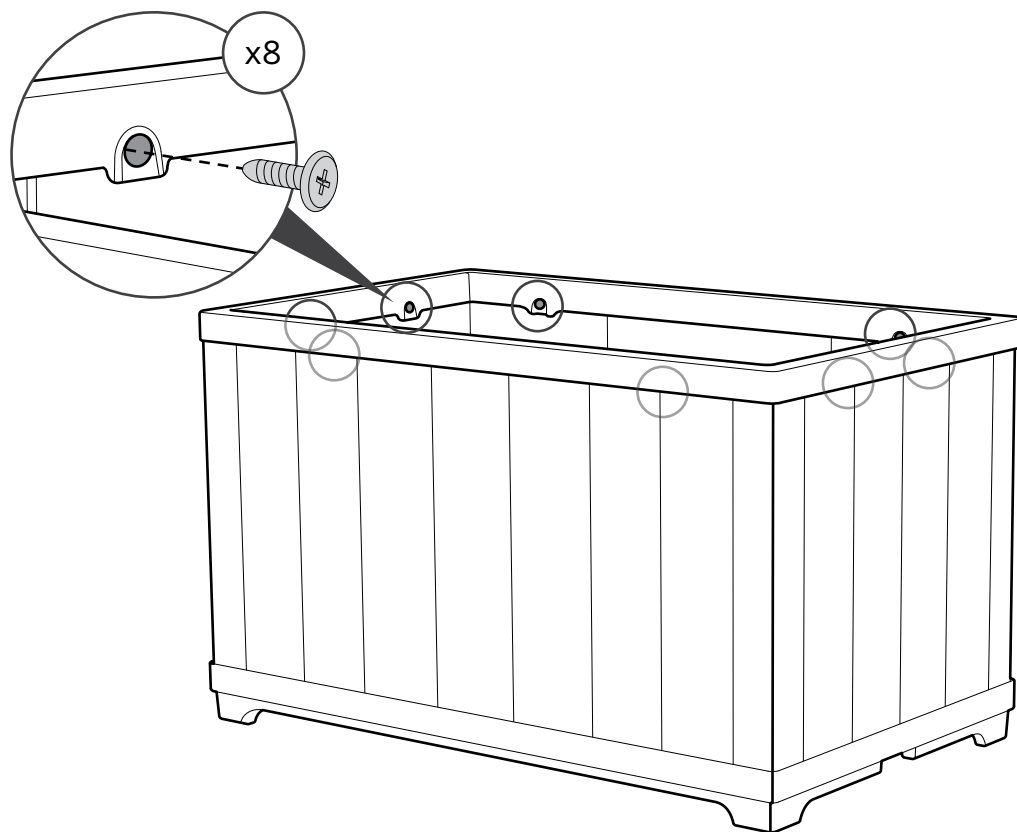

8



D (x1)



O-Ring (x1)

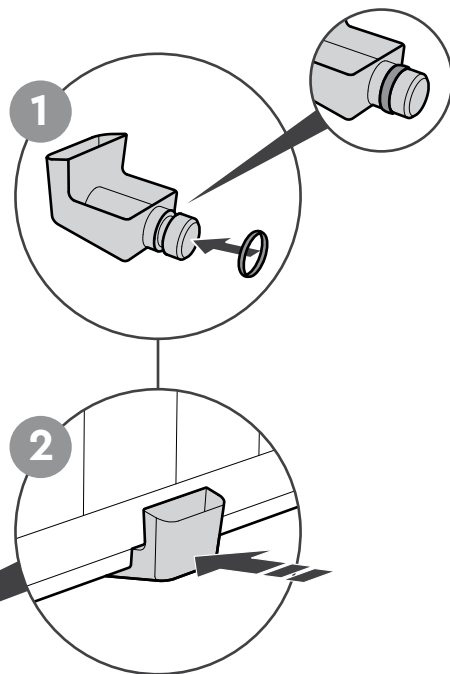
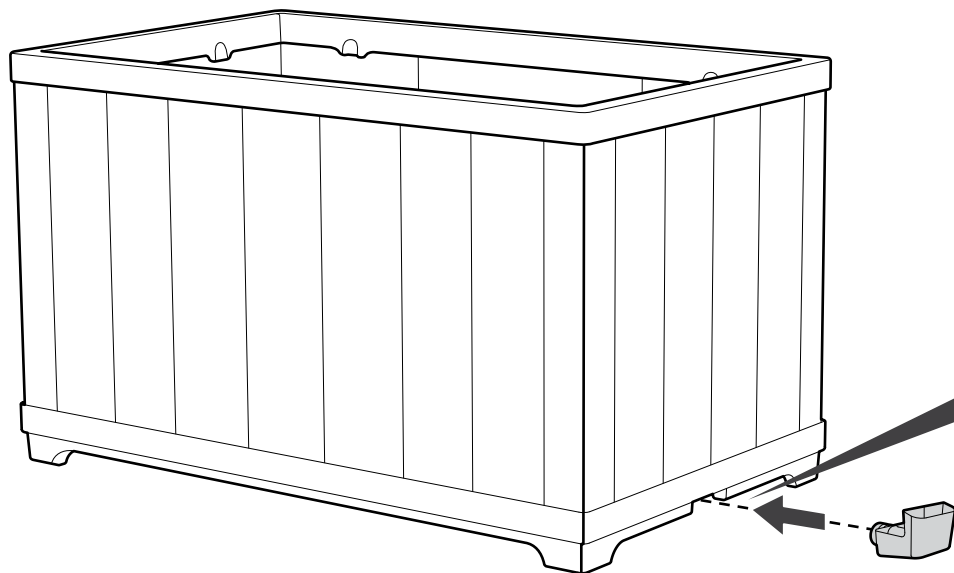

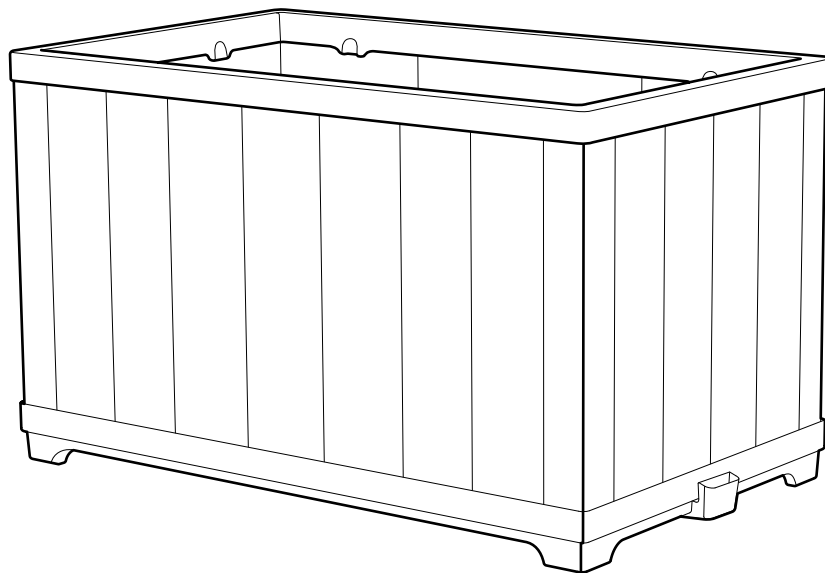

IF THERE ARE MISSING OR BROKEN PARTS, PLEASE DO NOT RETURN THE PRODUCT TO THE STORE.

PLEASE ACCESS OUR WEBSITE [WWW.KETER.COM](http://WWW.KETER.COM), OR CONTACT CUSTOMER SERVICE AT YOUR COUNTRY/REGION:

S'IL Y A DES PIÈCES MANQUANTES OU CASSÉES, NE RETOURNEZ PAS LE PRODUIT AU MAGASIN.

VEUILLEZ ACCÉDER À NOTRE SITE WEB [WWW.KETER.COM](http://WWW.KETER.COM) OU CONTACTER LE SERVICE CLIENT DE VOTRE PAYS/RÉGION:

SI HUBIERA ALGUNA PARTE FALTANTE O DAÑADA, NO DEVUELVA EL PRODUCTO A LA TIENDA.

ACCEDA A NUESTRA WEB [WWW.KETER.COM](http://WWW.KETER.COM) O CONTACTO CON EL SERVICIO DE ATENCIÓN AL CLIENTE DE SU PAIS/REGIÓN:

BITTE BRINGEN SIE IHR PRODUKT NICHT GLEICH ZUM LADEN ZURÜCK, FALLS TEILE FEHLEN ODER DEFECT SIND.

BITTE LOGGEN SIE IN UNSERE WEBSITE EIN ODER WENDEN SIE SICH AN UNSEREN KUNDENSERVICE:

IN GEVAL VAN ONTBREKENDE OF BESCHADIGDE ONDERDELEN KUNT U GEBRUIK MAKEN VAN DE KETER ONDERDELENSERVICE  
GA NAAR ONZE WEBSITE [WWW.KETER.COM](http://WWW.KETER.COM) OF NEEM CONTACT OP MET DE KLANTENSERVICE VIA ONDERSTAANDE CONTACTGEGEVENS:

IN CASO DI PARTI MANCANTI O ROTTE, PREGHIAMO DI NO RESTITUIRE IL PRODOTTO AL NEGOZIO.

CHIEDIAMO CORTESAMENTE DI ACCEDERE AL NOSTRO SITO WEB [WWW.KETER.COM](http://WWW.KETER.COM) O, CONTATTARE IL SERVIZIO CLIENTI DEL VOSTRO PAESE:

SE EXISTEREM PEÇAS DANIFICADAS OU PARTIDAS POR FAVOR NÃO EFECTUAR DEVOLUÇÃO À LOJA.

ACEDA AO NOSSO SITE [WWW.KETER.COM](http://WWW.KETER.COM) OU AO NOSSO SERVIÇO DE PÓS VENDA:

**US / Canada:** (EN/FR)

Tel: +1-888-374-4262  
[keter.com/en-us/contact-us.html](http://keter.com/en-us/contact-us.html)  
Email: [NACS@keter.com](mailto:NACS@keter.com)

**UK:** (EN)

Tel: +44-121-506-0008  
Email: [CSUK@keter.com](mailto:CSUK@keter.com)  
Keter UK Ltd  
16 Great Queen Street, Covent  
Garden, London, WC2B 5AH  
Mon - Fri | 8am - 4pm

**Israel:**

Tel: 1-700-70-6015

**Switzerland:**

Tel: +41-62-767-00-50  
Email: [info@neogard.ch](mailto:info@neogard.ch)

**France:**

Votre produit ayant été acheté dans une enseigne, qu'elle soit physique ou sur internet, c'est auprès de cette enseigne que vous devez faire votre demande SAV.

**Australia:**

Tel: 03 9544 6999  
Email: [keteraus@keter.com](mailto:keteraus@keter.com)  
28 Buckland St,  
Clayton, Victoria 3168  
Mon - Fri | 9am - 5pm

**Iberia:**

Email: [spvketer@carcaba.com](mailto:spvketer@carcaba.com)

**South Africa:**

Email: [info@keter.co.za](mailto:info@keter.co.za)

**Spain:** (SP)

Tel: +34-949-277-421  
Email: [spvketer@carcaba.com](mailto:spvketer@carcaba.com)  
Avenida Conde de Romanones 6-b.  
Polg. Ind. Miralcampo,  
19200 Azuqueca de Henares -  
Guadalajara, Spain  
Mon - Fri | 9am - 7pm

**Italy:**

Tel: +39 0422 745900  
Email: [Servizio.clienti@keter.com](mailto:Servizio.clienti@keter.com)

**고객센터:**

Tel: 031-767-2492  
Email: [info@keter.co.kr](mailto:info@keter.co.kr)  
월 - 금 | 9:00am - 05:30pm

**Poland:**

Tel: +48 59 84 19 892  
Email: [Service.poland@keter.com](mailto:Service.poland@keter.com)

**Hungary:**

Tel: +36 52 565 920  
Email: [Service.hungary@keter.com](mailto:Service.hungary@keter.com)

**Nordics:**

Tel: +48 59 84 19 892  
Email: [Service.nordic@keter.com](mailto:Service.nordic@keter.com)

**Germany/Austria:**

Tel: +49 (3) 222-10-96-42-1  
Email: [service@keter-ersatzteile.de](mailto:service@keter-ersatzteile.de)

**NL/BE/LUX:**

Email: [Klantenservice@keter.com](mailto:Klantenservice@keter.com)

**WWW.KETER.COM**



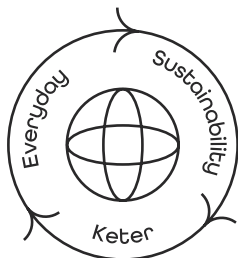

Le développement durable au quotidien | Sostenibilidad día a día



Designed to Last | Conçu pour durer | Diseñado para durar | Auf Langlebigkeit ausgelegt | Duurzaam ontworpen | Progettato per durare | Projetado para durar



Recyclability & Recycling | Recyclabilité et Recyclage | Reciclabilidad y reciclable | recyclefähig & recycelt | Recyclebaarheid & recycling | Riciclabilità e Riciclo | Reciclabilidade e Reciclagem



Community | Communauté | Comunidad | Community | Community | Comunità | Comunidade



Responsible Manufacturing | Fabrication responsable | Producción responsable | Verantwortungsbewusste Herstellung | Verantwoorde productie | Produzione responsabile | Fabricação responsável

Made in Israel by | Fabriqué en Israël par | Hecho en Israel por | Hergestellt in Israel von | Gemaakt in Israël door | Realizzato in Israele da | Fabricado em Israel por Keter Home and Garden Products Ltd., 1 Sapir St. Industrial Area, Herzliya 4685205, Israel



Donnez ou recyclez vos meubles.

Association

Magasin

Déchèterie

<https://quefairedemesdechets.fr>